



Designation: F 1541 – 02 (Reapproved 2007)<sup>ε1</sup>

## Standard Specification and Test Methods for External Skeletal Fixation Devices<sup>1</sup>

This standard is issued under the fixed designation F 1541; the number immediately following the designation indicates the year of original adoption or, in the case of revision, the year of last revision. A number in parentheses indicates the year of last reapproval. A superscript epsilon ( $\epsilon$ ) indicates an editorial change since the last revision or reapproval.

---

---

<sup>ε1</sup> NOTE—Units information was editorially corrected in August 2009.

---

---

### 1. Scope

1.1 This specification provides a characterization of the design and mechanical function of external skeletal fixation devices (ESFDs), test methods for characterization of ESFD mechanical properties, and identifies needs for further development of test methods and performance criteria. The ultimate goal is to develop a specification, which defines performance criteria and methods for measurement of performance-related mechanical characteristics of ESFDs and their fixation to bone. It is not the intention of this specification to define levels of performance or case-specific clinical performance of the devices, as insufficient knowledge is available to predict the consequences of the use of any of these devices in individual patients for specific activities of daily living. Furthermore, it is not the intention of this specification to describe or specify specific designs for ESFDs.

1.2 This specification describes ESFDs for surgical fixation of the skeletal system. It provides basic ESFD geometrical definitions, dimensions, classification, and terminology; material specifications; performance definitions; test methods; and characteristics determined to be important to the in-vivo performance of the device.

1.3 This specification includes a terminology and classification annex and five standard test method annexes as follows:

1.3.1 *Classification of External Fixators*—Annex A1.

1.3.2 *Test Method for External Skeletal Fixator Connectors*—Annex A2.

1.3.3 *Test Method for Determining In-Plane Compressive Properties of Circular Ring or Ring Segment Bridge Elements*—Annex A3.

1.3.4 *Test Method for External Skeletal Fixator Joints*—Annex A4.

1.3.5 *Test Method for External Skeletal Fixator Pin Anchorage Elements*—Annex A5.

1.3.6 *Test Method for External Skeletal Fixator Subassemblies*—Annex A6.

1.3.7 *Test Method for External Skeletal Fixator/Constructs Subassemblies*—Annex A7.

1.4 A rationale is given in Appendix X1.

~~1.5 The values stated in SI units are to be regarded as the standard.~~

1.5 The values stated in SI units are to be regarded as standard. No other units of measurement are included in this standard.

~~1.6 The following safety hazards caveat pertains only to the test method portions (Annex A2-Annex A6):~~

1.7 *This standard does not purport to address all of the safety concerns, if any, associated with its use. It is the responsibility of the user of this standard to establish appropriate safety and health practices and determine the applicability of regulatory limitations prior to use.*

### 2. Referenced Documents

2.1 *ASTM Standards*:<sup>2</sup>

A 938 *Test Method for Torsion Testing of Wire*

D 790 *Test Methods for Flexural Properties of Unreinforced and Reinforced Plastics and Electrical Insulating Materials*

E 4 *Practices for Force Verification of Testing Machines*

F 67 *Specification for Unalloyed Titanium, for Surgical Implant Applications (UNS R50250, UNS R50400, UNS R50550, UNS R50700)*

F 90 *Specification for Wrought Cobalt-20Chromium-15Tungsten-10Nickel Alloy for Surgical Implant Applications (UNS R30605)*

F 136 *Specification for Wrought Titanium-6Aluminum-4Vanadium ELI (Extra Low Interstitial) Alloy for Surgical Implant Applications (UNS R56401)*

---

<sup>1</sup> This specification is under the jurisdiction of ASTM Committee F04 on Medical and Surgical Materials and Devices and is the direct responsibility of Subcommittee F04.21 on Osteosynthesis.

Current edition approved June 15, 2007. Published June 2007. Originally published as F 1541 – 94. Last previous edition approved in 2002 as F 1541 – 02.

<sup>2</sup> For referenced ASTM standards, visit the ASTM website, [www.astm.org](http://www.astm.org), or contact ASTM Customer Service at [service@astm.org](mailto:service@astm.org). For *Annual Book of ASTM Standards* volume information, refer to the standard's Document Summary page on the ASTM website.

- F 138 Specification for Wrought 18Chromium-14Nickel-2.5Molybdenum Stainless Steel Bar and Wire for Surgical Implants (UNS S31673)
- F 366 Specification for Fixation Pins and Wires
- F 543 Specification and Test Methods for Metallic Medical Bone Screws
- F 544 Reference Chart for Pictorial Cortical Bone Screw Classification<sup>3</sup>
- F 1058 Specification for Wrought 40Cobalt-20Chromium-16Iron-15Nickel-7Molybdenum Alloy Wire and Strip for Surgical Implant Applications (UNS R30003 and UNS R30008)
- F 1264 Specification and Test Methods for Intramedullary Fixation Devices
- F 1472 Specification for Wrought Titanium-6Aluminum-4Vanadium Alloy for Surgical Implant Applications (UNS R56400)
- F 1713 Specification for Wrought Titanium-13Niobium-13Zirconium Alloy for Surgical Implant Applications (UNS R58130)

### 3. Terminology

3.1 *Definitions*—The definitions of terms relating to external fixators are described in Annex A1.

### 4. Classification

4.1 External skeletal fixators are modular devices assembled from component elements.

4.2 Test methods can address individual elements, for example, anchorage elements, bridge elements; subassemblies of elements, for example, connectors, joints, ring elements; or the entire fixator.

4.3 Tests of an entire assembled fixator may include the fixator alone, or alternatively, the fixator as anchored to a representation of the bone(s) upon which it typically would be mounted in clinical usage.

### 5. Materials

5.1 All ESFDs made of materials that have an ASTM standard shall meet those requirements given in ASTM Standards listed in 2.1.

### 6. Performance Considerations and Test Methods

6.1 *Individual Components*—The anchorage pins through which an ESFD is attached to a skeletal member or members typically experience high flexural, or torsional loads, or both. Often, the majority of the overall compliance of an ESFD is in its anchorage elements. A test method for evaluating the mechanical performance of an ESFD anchorage element in either of these loading modes is described in Annex A5.

6.2 *Subassemblies of Elements*:

6.2.1 The sites of junction between ESFD anchorage elements, for example, pins, and bridge elements, for example, rods, normally require specialized clamping or gripping members, known as connecting elements. Often, connecting elements are subjected to high loads, especially moments, so adequacy of their intrinsic mechanical stiffness, or strength, or both, is critical to overall fixator performance. A test method for evaluating the mechanical performance of ESFD connector elements is described in Annex A2.

6.2.2 ESFDs involving ring-type bridge elements are used widely both for fracture treatment and for distraction osteogenesis. The anchorage elements in such fixators usually are wires or thin pins, which pass transverse to the bone long axis and which are tensioned deliberately to control the longitudinal stiffness of the fixator. Tensioning these wires or pins causes appreciable compressive load in the plane of the ring element. A test method for evaluating the mechanical performance of ESFD ring elements in this loading mode is described in Annex A3.

6.2.3 The high loads often developed at ESFD junction sites are of concern both because of potentially excessive elastic deformation and because of potential irrecoverable deformation. In addition to the connecting element itself (Annex A2), overall performance of the junction also depends on the interface between the connecting element and the anchorage, or bridge elements, or both, which it grips. A test method for evaluating the overall strength, or stiffness, or both, at an external fixator joint, as defined in Annex A1 as the connecting element itself plus its interface with the anchorage, or bridge, or both, elements, which it grips, is described in Annex A4.

6.2.4 The modular nature of many ESFD systems affords the surgeon particularly great latitude as to configuration of the frame subassembly, as defined in Annex A1 as the bridge elements plus the connecting elements used to join bridge elements, but specifically excluding the anchorage elements. Since configuration of the frame subassembly is a major determinant of overall ESFD mechanical behavior, it is important to have procedures for unambiguously characterizing frame subassemblies, both geometrically and mechanically. Test methodology suitable for that purpose is described in Annex A6.

6.3 *Entire Assembled Fixator*—No test methods are yet approved for entire assembled fixators.

### 7. Keywords

7.1 anchorage element; bending; bridge element; connector; external skeletal fixation device; fracture fixation; joints; modularity; orthopedic medical device; osteosynthesis; ring element; subassembly (frame); terminology; torsion

<sup>3</sup> Withdrawn.

## ANNEXES

### (Mandatory Information)

#### A1. CLASSIFICATION OF EXTERNAL SKELETAL FIXATORS

##### A1.1 Scope

A1.1.1 This classification covers the definitions of basic terms and considerations for external skeletal fixation devices (ESFDs) and the mechanical analyses thereof.

A1.1.2 It is not the intent of this classification to define levels of acceptable performance or to make recommendations concerning the appropriate or preferred clinical usage of these devices.

A1.1.3 *This standard does not purport to address all of the safety concerns, if any, associated with its use. It is the responsibility of the user of this standard to establish appropriate safety and health practices and determine the applicability of regulatory limitations prior to use.*

##### A1.2 Referenced Documents

A1.2.1 *ASTM Standards:*<sup>2</sup>

F 366 [Specification for Fixation Pins and Wires](#)

F 543 [Specification and Test Methods for Metallic Medical Bone Screws](#)

F 544 [Reference Chart for Pictorial Cortical Bone Screw Classification](#)<sup>0</sup>

##### A1.3 Background

A1.3.1 ESFDs are in widespread use in orthopedic surgery, primarily for applications involving fracture fixation or limb lengthening, or both. The mechanical demands placed on these devices often are severe. Clinical success usually depends on suitable mechanical integration of the ESFD with the host bone or limb.

A1.3.2 It is important, therefore, to have broadly accepted terminology and testing standards by which these devices can be described and their mechanical behaviors measured.

A1.3.3 Useful terminology and testing standards must take into account that the modular nature of most ESFDs deliberately affords a great deal of clinical latitude in configuring the assembled fixator.

##### A1.4 Significance and Use

A1.4.1 The purpose of this classification is to establish a consistent terminology system by means of which these ESFD configurations can be classified. It is anticipated that a companion testing standard using this classification system will subsequently be developed.

##### A1.5 Basis of Classification

A1.5.1 An assembled ESFD and the bone(s) or bone analog(s) to which it is affixed constitute a *fixator-bone construct*.

A1.5.1.1 The assembled ESFD itself, apart from the host bone, is termed the *fixator assembly*.

A1.5.1.2 The individual parts (or modules of individual parts) from which the end user assembles the fixator are termed its *elements*.

A1.5.2 An ESFD normally is configured to span a mechanical discontinuity in the host bone that otherwise would be unable to transmit one or more components of the applied functional load successfully. This bony discontinuity is termed the *mechanical defect*.

A1.5.3 Examples of mechanical defects are fracture surfaces, interfragmentary callus, segmental bone gaps, articular surfaces, neoplasms, and osteotomies.

A1.5.4 *Coordinate System(s)*—The relative positions of the bones or bone segments bordering the mechanical defect should be described in terms of an orthogonal axis *coordinate system* (Fig. A1.1).

A1.5.4.1 Where possible, coordinate axis directions should be aligned perpendicular to standard anatomical planes, for example, transverse (horizontal or axial), coronal (frontal), and sagittal (median).

A1.5.4.2 Where possible, translation directions should be consistent with standard clinical conventions, for example, ventral (anterior), dorsal (posterior), cranial (cephalad or superior), caudal (inferior), lateral, or medial.

A1.5.4.3 Rotation measurement conventions must follow the right-hand rule and, where possible, should be consistent with standard clinical terminology, for example, right or left lateral bending, flexion, extension, and torsion.

A1.5.5 A base coordinate system ( $X$ ,  $Y$ ,  $Z$ ) should be affixed to one of the bones or major bone segments bordering the mechanical defect. This bone or bone segment is termed the *base segment*,  $S_b$ , and serves as a datum with respect to which pertinent motion(s) of bone segments or fixator elements, or both, can be referenced. Depending on context,  $S_b$  may be defined as being on either the proximal or the distal side of a mechanical defect.

A1.5.6 The other bone(s) or bone segment(s) bordering the mechanical defect, whose potential motion(s) with respect to  $S_b$  is

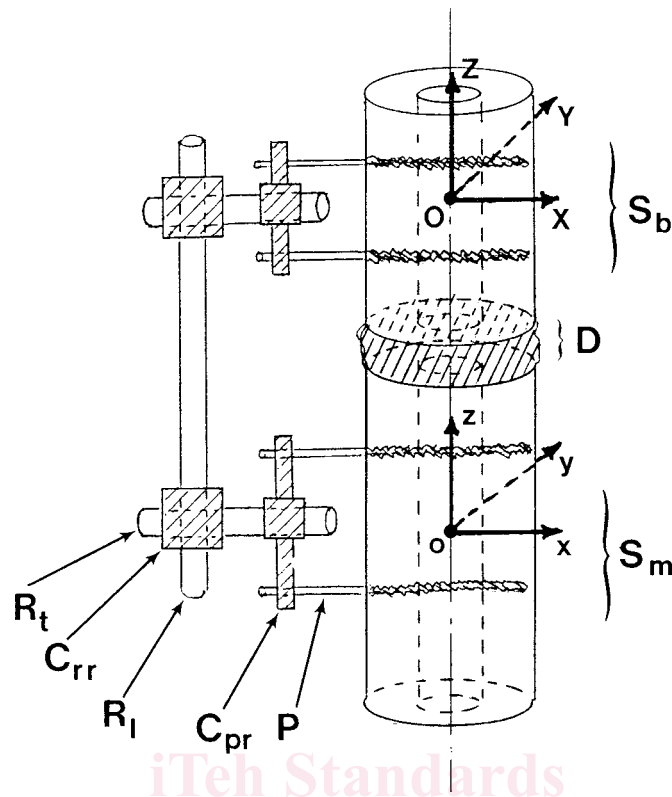

- $S_b$  = base segment
- $S_m$  = mobile segment
- $D$  = mechanical defect
- $O$  = origin of base reference frame
- $X, Y, \text{ and } Z$  = base reference frame axes
- $o$  = origin of mobile reference frame
- $x, y, \text{ and } z$  = mobile reference frame axes
- $R_t$  = transverse rod
- $R_l$  = longitudinal rod
- $P$  = pin
- $C_{rr}$  = rod-rod connector
- $C_{pr}$  = pin-rod connector

FIG. A1.1 External Fixator Definition Schematic

of interest, is termed the *mobile segment(s)*,  $S_m$ . If necessary, a local right-handed orthogonal coordinate system ( $x, y, z$ ) may be embedded within the  $S_m(s)$ .

A1.5.7 *Degrees of Freedom:*

Describing the position, or change in position, of  $S_m$  relative to  $S_b$  requires specifying one or more independent variables. These variables will be termed *positional degrees of freedom* (P-DOF).

A1.5.7.1 Depending on context, this may involve as many as six variables (three translation and three orientation).

A1.5.7.2 Also depending on context, P-DOFs may be used to describe motions of interest in various magnitude ranges. For example, P-DOFs may be used to describe one or more components of visually imperceptible motion, for example, elastic flexure of a thick rod) or one or more components of grossly evident motion, such as, interfragmentary motion at an unstable fracture site.

A1.5.8 Application or adjustment of an ESFD normally includes an attempt to achieve or maintain a specific position of  $S_m$  relative to  $S_b$ . The adjustability afforded by the ESFD design for this purpose, most commonly, fracture fragment reduction, will be characterized in terms of *adjustment degrees of freedom* (A-DOF).

A1.5.9 Some ESFDs are designed optionally to transmit selected components of loading or displacement across the defect, usually by disengaging a locking mechanism. The component of motion of  $S_m$  permitted by such unlocking, often given the clinical name “dynamization,” will be termed *unlocked degrees of freedom* (U-DOF).

A1.5.9.1 Depending on the specifics of design, the motion permitted in an unlocked degree of freedom may be opposed substantially and deliberately by a specific mechanism such as a spring or a cushion. Such an unlocked degree of freedom is termed a *resisted* unlocked degree of freedom.

A1.5.9.2 Unlocked degrees of freedom in which motion is induced actively by external energy input from devices associated with the fixator are termed *actuated* degrees of freedom.

A1.5.9.3 An unlocked degree of freedom in which motion is unopposed by a specific design mechanism is termed an *unresisted*

unlocked degree of freedom. Incidental friction in a dynamizing element shall not be construed as representing deliberately resisted motion; however, conditions involving untoward resistance to motion, for example, substantial binding friction, in a supposedly unresisted degree of freedom should be identified.

A1.5.10 For adjustment or unlocked DOFs, the extrema of angular or translational displacement between which motion is permitted before encountering a fixed or adjustable constraint are termed that DOF's *range of motion* (ROM).

A1.5.11 A *fixator assembly* consists of a structurally purposeful arrangement of three basic types of *elements*: bone anchorage elements, usually transcutaneous, bridge elements, usually extracutaneous, and connection elements.

A1.5.12 *Anchorage elements* are those that attach directly to the bone. Examples are smooth pins, threaded pins, screws, wires, or cortex clamps.

A1.5.13 *Bridge elements* are structural members designed to transmit loads over relatively long distances, and they are joined to one another or to anchorage elements, or both, by connectors. Bridge elements can either be simple or complex and should be described in terms of their characteristic shape and, where appropriate, their orientation with respect to the bone or the mechanical defect.

A1.5.13.1 Examples of *simple bridge elements* are longitudinal rods, transverse rods, rings, or ring segments. Simple bridge elements need not be single-piece. If multipiece, however, the individual parts are joined rigidly rather than adjustable by the end user.

A1.5.13.2 *Complex bridge elements* are mechanisms that consist of two or more subelements designed to function together to achieve a specific kinematic objective. Examples of complex bridge elements are articulated or telescoping mechanisms.

A1.5.14 *Connectors* join bridge elements either to other bridge elements or to anchorage elements. Of the two elements comprising any joint or junction, the connector is that element to which the end user applies an active gripping force or torque to engage the attachment. Connectors should be described in terms of the types of elements that they connect and, where appropriate, in terms of their adjustment or unlocked degrees of freedom. Examples of connectors are pin(-rod) clamps, pin cluster(-rod) clamps, ring-rod clamps, and rod-rod clamps.

A1.5.15 That portion of the fixator assembly specifically excluding the bony anchorage elements and their associated connectors is termed the *frame*. Connectors that join only bridge elements, or that join bridge elements to bone anchors but are not user removable from bridge elements, are considered to be part of the frame.

A1.5.16 A joint or junction for which the relative positions between any two elements or subelements can be controlled by the end user is termed an *articulation*. The components of relative motion permitted between the fixator elements at an articulation should be described in terms of that articulation's degrees of freedom, either A-DOF or U-DOF, depending on context. Additionally, articulations should be described in terms of the types of elements that they connect.

A1.5.17 Joints at which the relative positions of the elements connected are fixed and cannot be controlled by the end user are termed *nonadjustable*. Nonadjustable joints should be described in terms of the types of elements that they connect.

## A1.6 Attributes

A1.6.1 Coupling between the assembled frame and the host bone is achieved by anchorage elements such as wires, pins (threaded or unthreaded), screws, or cortex clamps (sometimes called claws or prongs). In long bone applications, anchorage elements normally transmit load transversely from the host bone segments to the frame structure.

A1.6.1.1 *Wires* are thin, smooth, constant cross-section (usually circular) anchorage elements that transmit load from the host bone to the frame primarily by axial tension as a result of transverse ("bow string") distention by the host bone; therefore, wires must transfix the bone and must be clamped to the frame at two sites. The stiffness of bone-frame coupling achieved using a wire depends sensitively on the tension in the wire, which normally is controlled by the end user. *Stoppers* ("olives") sometimes are used to oppose incidental slippage along the length of a transfixing wire.

A1.6.1.2 *Pins* are slender anchorage elements, again, usually of circular cross section or envelope, for which bone-to-frame load transmission occurs primarily by longitudinal bending stresses. Pins can penetrate one or (usually) both cortices of a long bone, and they can be clamped to the frame at one end ("half-pins") or both ends ("through-and-through pins" or "full-pins"). Pins can either be smooth or threaded. Threaded pins can be designed for achieving purchase in cortical bone, cancellous bone, or in a combination of the two. Pins can either be of constant cross section, shouldered, or tapered. They can be clamped to the frame either individually or in clusters. Depending on the flute or thread design, or both, pins can be classified as being one of the following:

- (1) Self-drilling/self-tapping,
- (2) Self-tapping/nonsel-drilling, or
- (3) Nonsel-tapping/nonsel-drilling.

A1.6.1.3 *Screws* are threaded anchorage elements, loaded primarily in axial tension or in transverse shear, or both. This term is sometimes (mis)used interchangeably as a descriptor for ESFD threaded pins, but it is reserved more properly for devices that have a head with a recess for wrenching (see Specification F 543 and Reference Chart F 544) and that are used to develop compression across a fracture site or across a bone/implant interface.

A1.6.1.4 *Cortex clamps* (claws/prongs) are anchors that grip the host bone externally at two or more sites, without penetrating through the full cortical thickness. Cortex clamps may or may not pierce the periosteum.

A1.6.2 Frame *bridge elements* are structural members configured in such a manner as to transmit functional load from the

anchorage elements on one side of the mechanical defect to those on the other side of the defect. Bridge elements can be simple members such as smooth prismatic rods, threaded rods, bars, flat plates, curved plates, or arched plates. Alternatively, they can be complex assemblies of several members, designed to allow or induce specific motions such as fixed axis rotation, linear sliding, or active adjunct distraction. Most ESFD frames using simple bridge elements involve structural arrangements in which several simple bridge elements are linked to one another by connectors.

A1.6.3 *Fixator-Bone Construct Classifications*—Constructs may be classified in accordance with the anatomic skeletal structure to which the frame is applied. Common types are as follows:

- A1.6.3.1 Long bone,
- A1.6.3.2 Articular joint,
- A1.6.3.3 Pelvis,
- A1.6.3.4 Spinal, and
- A1.6.3.5 Halo (skull).

A1.6.3.6 A *construct subunit* is one bony fragment plus its pins/wires and connectors and plus bridge elements not shared with other bony fragments.

A1.6.4 Long bone frames or frame subunits can be characterized in terms of limb access.

A1.6.4.1 Frames or frame subunits that encompass 90° or less of an extremity sector circumferentially are termed *unilateral*.

A1.6.4.2 Frames or frame subunits that encompass more than 90° of an extremity sector circumferentially are termed *multilateral*. Multilateral frames are often described in terms of their characteristic geometry: bilateral (two columns of longitudinal bridge elements), triangular (three longitudinal columns), quadrilateral (four columns), or circular (ring fixators).

A1.6.5 Long bone frames or frame subunits (unilateral or multilateral) can be classified according to pin configuration, as follows:

- A1.6.5.1 As *one plane* if all of their pins lie approximately within a common plane,
- A1.6.5.2 Or as *multiplane* if their pins lie in two or more distinct planes.

A1.6.6 Constructs may be classified in terms of the means by which the frame is coupled to the bone.

A1.6.6.1 A frame for which coupling to the bone is by a homogeneous group of primarily moment-transmitting anchors such as pins, screws, or cortex claws is termed a *pin-fixed* construct.

A1.6.6.2 If the coupling is by primarily tension-transmitting members instead, the construct is said to be *wire fixed*. The wire-fixed constructs involve ring-type bridge elements in almost all instances.

A1.6.6.3 If coupling involves a heterogeneous mixture of wires and pins (or screws or other anchorage elements, or both), the construct is said to incorporate *hybrid coupling*.

A1.6.7 Fixator constructs may be classified according to the degree of homology or similarity between the respective subunits.

A1.6.7.1 If the bone fragments on opposing sides of a mechanical defect are part of analogously assembled construct subunits, the overall fixator is said to be *symmetrically configured*. This does not imply strict geometric symmetry about the defect mid plane, but rather that each major element in each construct subunit possesses a similar counterpart in the other construct subunit.

A1.6.7.2 A construct whose subunits do not have such counterpart elements is said to have a *hybrid*, or *asymmetrically configured*, frame.

A1.6.8 Some pin-fixed constructs allow *independent control* of each pin's orientation and DOF of articulation with the frame. In other designs, *multipin clamps* are used to control the common orientation and DOF of frame articulation of a small group of pins termed a *pin cluster*. Pin cluster clamps most commonly enforce parallel alignment of the pins in the cluster. The specific A-DOF and U-DOF of pin/frame articulation in each instance, that is, either independent or clustered pins, depends on the design of the specific connecting element joining the pin(s) to the frame.

A1.6.9 *Ring fixators* have complex frames assembled from several transverse-plane ring or partial-ring bridge elements. The anchoring transfixation tensile wires are connected to the rings individually. Longitudinal rods normally are used to connect the transverse-plane rings.

## A2. TEST METHOD FOR EXTERNAL SKELETAL FIXATOR CONNECTORS

### A2.1 Scope

A2.1.1 This test method covers the procedures for determining the stiffness and strength of connecting elements (clamps) of external skeletal fixators under axial loads and bending moments. Depending on the design of the connector and its use in the overall construct, the connector needs to transmit one or more components of loading (tension, compression, torsion, or bending, or a combination thereof) between the elements it grips (anchorage elements or bridge elements), without itself undergoing either permanent deformation or excessive elastic deformation.

A2.1.2 *This standard does not purport to address all of the safety concerns, if any, associated with its use. It is the responsibility of the user of this standard to establish appropriate safety and health practices and determine the applicability of regulatory limitations prior to use.*

### A2.2 Referenced Documents

- A2.2.1 *ASTM Standards*:<sup>2</sup>

## E 4 Practices for Force Verification of Testing Machines

### A2.3. Terminology

#### A2.3.1 Definitions of Terms Specific to This Standard:

A2.3.1.1 *connectors, n*—external fixator elements used to join bridge elements either to other bridge elements, or to anchorage elements.

(1) Of the two elements comprising any joint or junction, the connector is that element to which the end user applies an active gripping force or torque to engage the attachment.

(2) Connectors should be described in terms of the types of elements, which they connect, and where appropriate, in terms of their adjustment or unlocked degrees of freedom.

(3) Examples of connectors are pin(-rod) clamps, pin cluster(-rod) clamps, ring-rod clamps, and rod-rod clamps.

A2.3.1.2 *input-loading axis, n*—the line of application in the case of a force input, or the axis about which a moment is applied in the case of a moment input.

A2.3.1.3 *input-loading platen, n*—a member, not normally part of the connector during clinical usage, through which the input force, or moment, is delivered from the testing machine actuator to the connector.

A2.3.1.4 *support platen, n*—a member, also not normally part of the connector during clinical usage, through which the connector is rigidly affixed to the testing machine base.

### A2.4 Summary of Test Method

A2.4.1 Connecting elements (clamps) are obtained, and if applicable, assembled using the techniques and equipment recommended by the manufacturer. Platens substituting for the body, or anchorage elements, or both, are attached to the connector in such a manner that no slippage can occur relative to the connector. Axial loads or bending moments are applied to the connector, and a graphical plot of load (or moment) versus displacement is used to determine the intrinsic stiffness, and strength, if tested to failure, of the connector.

### A2.5 Significance and Use

A2.5.1 These laboratory benchtop tests are used to determine values for the intrinsic stiffness, or strength, or both, of connectors, under force or moment loadings. Since different connectors have different materials and geometries, stresses within individual subcomponents or at subcomponent interfaces may differ substantially between designs. During testing, the connectors are loaded and supported in such a manner that all measured deformation occurs within the connector itself, rather than at the interface between the connector and the fixator element(s) gripped.

A2.5.2 The results obtained in this test method are not intended to predict the clinical efficacy or safety of the tested elements. This test method is intended only to measure the uniformity of the elements tested or to compare the mechanical performance of different connectors; however, the actual load that can be transmitted to the connector in clinical practice depends very much on the slippage resistance of the different subcomponent interfaces.

A2.5.3 This test method may not be appropriate for all types of external skeletal fixator applications. The user is cautioned to consider the appropriateness of the method in view of the materials and designs being tested and their potential application.

### A2.6 Apparatus

#### A2.6.1 Force or Moment or both Application Fixture:

A2.6.1.1 The loading configuration is shown schematically in Fig. A2.1. The input loading axis must pass through one of the platens (the loading platen) rigidly affixed to the connector. The other platen (the support platen) is rigidly affixed to the base of the testing apparatus.

A2.6.2 *Load Frame*—Machines used for testing shall conform to the requirements of Practices E 4. The loads used for this test method shall be within the loading range of the test machine as defined in Practices E 4.

A2.6.3 *Data Acquisition Device*—A suitable recorder to plot a graph of load versus load frame displacement on perpendicular axes. Optionally, this device may include the use of computer-based digital sampling and output of the load and displacement signals.

### A2.7 Test Specimen

A2.7.1 All tested connectors should be representative of clinical quality products.

A2.7.2 If the connector(s) to be tested have been used previously, the nature of such prior usage should be described appropriately.

A2.7.3 The test specimens should be prepared in the manner in which they would normally be used clinically. For example, if a particular connector would normally be sterilized in a particular manner before clinical use, it should be similarly sterilized before mechanical testing.

A2.7.4 If the connector to be tested is a prototype, or under development, or both, the geometric and material information needed to characterize the component fully should either be included in the report, or detailed descriptive information should be referenced.

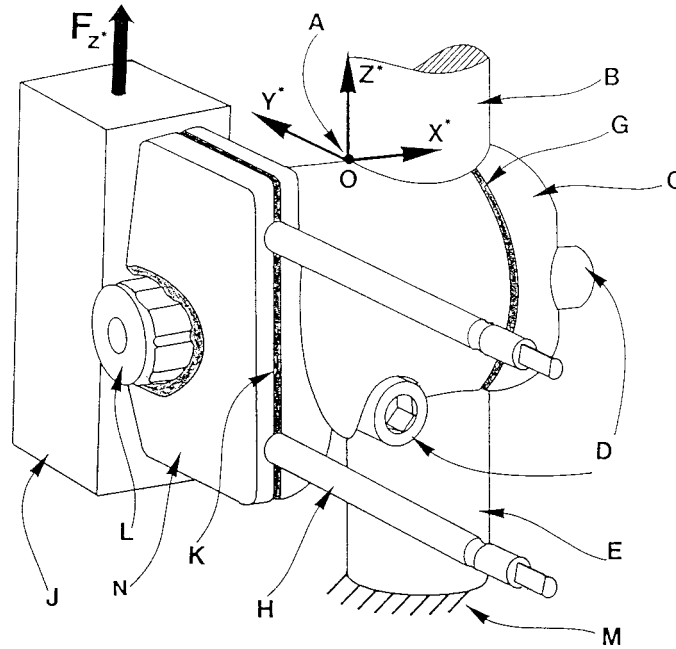

- A = local coordinate system, defined with respect to landmark Point O
- B = rod (as normally gripped by connector)
- C = connector body
- D = connector tightening mechanism(s)
- E = rod grip platen (support platen)
- G = rod grip interface
- H = pins (as normally gripped by connector)
- J = pin grip/clamp platen (loading input platen, rigidly bonded to pin grip)
- K = pin clamping interface
- L = pin grip/clamp tightening mechanism
- M = testing machine base (fixed)
- N = pin grip/clamp (in this illustration, the input loading is a force  $F_{z^*}$  in the  $z^*$  direction, delivered through a loading platen rigidly affixed to the pin grip/clamp.  $\delta_z$  is the displacement of the loading platen in the  $z$  direction)

FIG. A2.1 Schematic for Testing an External Fixator Connector (Example, Generic for a Pin-Rod Joint)

## A2.8 Procedure

### A2.8.1 Configuring the Connecting Element for Testing:

A2.8.1.1 With the connecting element assembled in the configuration normally used, input and support platens are affixed in a manner that insures that all measured deformations are intrinsic to the connecting element itself and are not influenced by possible interfacial slippage between the connecting element and the fixator elements, for example, rods or anchorage pins, which it clamps.

(1) The input and support platens should be made of steel or other metal and should have negligible compliance relative to that of the connecting element itself.

(2) The input and support platens should have recesses to accommodate those fixator elements geometrically, for example, anchorage pins or rods, normally clamped by the connecting element being tested.

(3) The input and support platens should be rigidly affixed to the connecting element, for example, by welding, epoxy, cyanoacrylate cement, or other appropriate means.

A2.8.1.2 The input and support platens serve as attachments for gripping by the testing apparatus. This test method is applicable only to those components of loading (force or moment, or both), which can be applied through such platens.

A2.8.1.3 A local right-handed coordinate system ( $X^*$ ,  $Y^*$ ,  $Z^*$ ) should be defined with respect to a specific origin landmark point on (or in) the connecting element. The platen locations (position and orientation) should be identified relative to these local coordinate axes.

### A2.8.2 Mounting the Test Connector:

A2.8.2.1 The platen through which the input force (or moment) is to be applied is gripped, appropriately aligned, in the testing machine. The support platen is rigidly affixed to the testing machine base.

A2.8.2.2 The grips and the testing machine itself should be sufficiently stiff that their deformation under load is negligible



relative to that of the connecting element being tested. The tare compliance of the testing machine and grips, that is, without the connector mounted, should be measured and reported. Typically, the tare compliance of the testing machine plus grips should be less than 1 % of the compliance of the connector being tested. The gripping mechanism should be clearly described.

A2.8.3 Forces should be delivered through an input platen, which is rigidly bonded to the connector. Normally, the axis of loading will be referenced to that of a member, such as a rod or a pin, that would be clamped by the connector. The line of action of the input force should be recorded relative to the local coordinate system. Appropriate fixturing detail should be provided as to how that force is applied through the input platen.

A2.8.4 Moments may be delivered either by an eccentrically applied force, or alternatively, by a torsional actuator. In the former instance, the offset from the local coordinate system origin should be recorded. In either instance, the orientation of the moment axis should be recorded relative to the local coordinate system. Appropriate fixturing detail should be provided as to how that moment is applied through the input platen.

A2.8.5 For connectors made entirely of metal or other materials exhibiting elastic behavior, the load (or moment) may be applied quasistatically. An input rate sufficient to attain in 30-s force, or moment, magnitude in the range of typical clinical usage, or of connector failure, shall be deemed quasistatic. For connectors incorporating polymeric or other materials that exhibit viscoelastic behavior, load/stroke rates, which are in the range of those expected clinically, may instead be desirable. In either case, the rate(s) used and a rationale for its choice should be provided.

A2.8.6 Tests may be run under either load or displacement control. They may either be single- or multi-cycle, and can be either restricted to the elastic regime, or taken to failure of the connector. The specific conditions used should be described fully.

A2.8.7 If single-cycle testing is to be performed, the specimen must be subjected to several preconditioning load cycles to demonstrate that the reported load/deformation curve is repeatable from cycle to cycle.

A2.8.7.1 Preconditioning should be continued until the apparent stiffness of the connector changes less than 5 % between subsequent cycles.

A2.8.7.2 Normally, about five preconditioning load cycles are suitable for this purpose, with peak applied load within the elastic range, approximately 50 % of the expected physiologic service load or 50 % of the expected connector failure load, whichever is lower.

A2.8.7.3 Load/deformation curves for the preconditioning cycles should be recorded. Preconditioning cycle stiffnesses should be reported.

A2.8.8 *Data Recording*—The load (N) or torque (N-m) and linear (mm) or angular (°) displacement measured by the testing machine should be continuously recorded. The linear displacement should be measured at the point of load application. In some instances it may be appropriate also to record components of deformation in directions other than that of the applied loading. If so, the sensors used, for example, dial gages or LVDTs, and the points and directions of their measured deformations should be recorded.

## **A2.9 Calculation or Interpretation of Results**

A2.9.1 Stiffness (units according to the chosen load and deflection configuration, for example, N/mm for force, N-mm/degree for moment) shall be calculated from the slope of the linear-most portion of the load/deflection curve, as apparent visually (Fig. A2.2, Point A). If an objective slope determination technique, for example, curve fitting of a digitized tracing, is used, this should be described. The load and deflection configuration (location of measuring element and direction of the measured vector) must be defined clearly with respect to the loading axis of the testing equipment (Fig. A2.1).

A2.9.2 Failure load (N or N-mm) of the connector is associated frequently with a discontinuity in the load/deformation curve. Depending on context, additional load uptake may or may not be possible after occurrence of this discontinuity. In the former circumstance (Fig. A2.2, Point B), the severity of the discontinuity should be measured in terms of change in slopes of the load/deformation curve for loads immediately below and above the discontinuity point. In the latter circumstance (Fig. A2.2, Point C), the failure load should be designated as the ultimate strength of the connector.

A2.9.3 In situations in which there is no clear discontinuity in the load displacement curve, other definitions of failure load may be used.

A2.9.3.1 For situations in which permanent deformation occurs, for example, as a result of interfacial slip or plastic deformation, or both, within the connector, an offset criterion may be used. In this instance, the failure load is defined as that load necessary to induce a specific amount of permanent deformation, either linear or angular, depending upon the degree of freedom being tested, upon release of the applied load.

A2.9.3.2 For situations in which excessive elastic deformation occurs within the connector, failure may be defined in terms of a specific fractional reduction of the connector's small-load stiffness. For example, failure might be defined in terms of the connector's tangent stiffness having fallen to 25 % of the tangent stiffness that was apparent at a load of 50 N.

## **A2.10 Report**

A2.10.1 The test report shall include, but is not limited to, the following information:

A2.10.1.1 *Connecting Element Identification*, including manufacturer, part number, nomenclature, and quality control or lot number. If the part is a prototype, geometrical and material descriptions shall be included.

A2.10.1.2 Specimen preparation condition, for example, sterilization and description of prior usage history, if applicable.

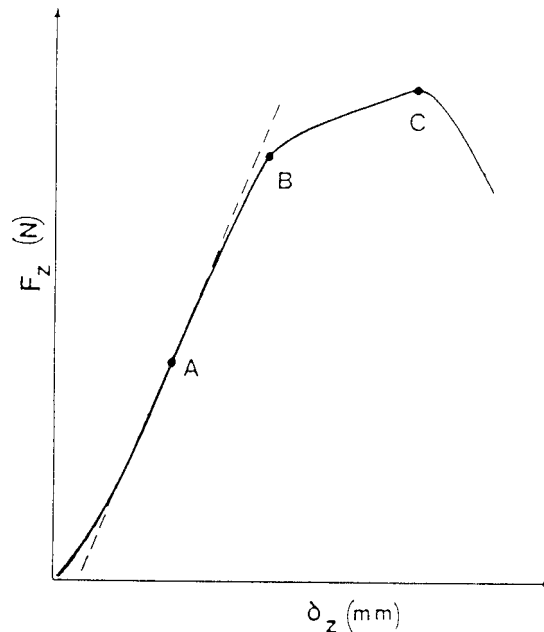

NOTE—Stiffness is defined as the slope of the linear-most portion of the curve, here evaluated by a tangent drawn at Point A. Point B illustrates a slope discontinuity (possibly indicative of interfacial slip or subcomponent failure within the connector), and Point C illustrates the maximal load acceptance (ultimate strength).

FIG. A2.2 Load/Deformation Curve (Generic, Here Illustrated for the  $z^*$  Direction)

- A2.10.1.3 Connecting force or torque used to engage the connector's gripping mechanism.
- A2.10.1.4 Configuration of the (bonded) platens and testing apparatus grips.
- A2.10.1.5 Specific degrees of freedom tested, such as, tension or compression, torsion, or bending. In each case, the axis along which or about which loading is applied should be specified.
- A2.10.1.6 Loading rate and number of cycles (fatigue tests).
- A2.10.1.7 Stiffness, and, if loaded to failure, the failure criterion and strength, in the specific direction(s) tested.
- A2.10.1.8 In cases in which the mode of failure is ascertainable, for example, visually apparent interfacial slippage of a specific subcomponent interface, the nature of such failure should be described.

### A2.11 Precision and Bias

A2.11.1 Data establishing the precision and bias to be expected from this test method have not yet been obtained.

## 12. Keywords

12.1 bending moments; connecting elements; connectors; external fixator; orthopedic device; stiffness; strength

### A2.13 Rationale

A2.13.1 Connecting elements of various designs are used widely in external fixators. Both the elements connected and the pertinent directions of force, or moment, or both, transmission through them are design and site specific. This test method provides an outline by which the stiffness, or strength, or both, intrinsic to the connector itself, as opposed to the stiffness or strength by which it grips the elements it connects, can be measured. Since the joints of external fixators normally involve abrupt redirection of appreciable loads, substantial stresses often are developed within one or more of the subcomponents of the connector securing the joint.

A2.13.2 Even if there is no apparent interfacial slippage between the connector and the various bridge or anchorage elements it grips, the associated elastic deformations within the connector body itself may result in appreciable distension of the overall frame. Moreover, excessive forces, or more commonly, moments, applied to a connector may cause destructive failure of the connector body, even if gripped interfaces remain intact. This test method focuses on the intrinsic load/deformation behavior of the connector body, independent of whether or not there is interfacial slip between the connector and the bridge or anchorage elements, or both, which it grips. This goal is achieved by means of platens, which are bonded rigidly to the connector.

### A3. TEST METHOD FOR DETERMINING IN-PLANE COMPRESSIVE PROPERTIES OF CIRCULAR RING OR RING SEGMENT BRIDGE ELEMENTS

#### A3.1 Scope

A3.1.1 This test method covers the test procedure for determining the in-plane compressive properties of circular or ring segment bridge elements of external skeletal fixators.

A3.1.2 *This standard does not purport to address all of the safety concerns, if any, associated with its use. It is the responsibility of the user of this standard to establish appropriate safety and health practices and determine the applicability of regulatory limitations prior to use.*

#### A3.2 Referenced Documents

A3.2.1 *ASTM Standards:*<sup>2</sup>

E 4 [Practices for Force Verification of Testing Machines](#)

#### A3.3. Terminology

A3.3.1 *Definitions of Terms Specific to This Standard:*

A3.3.1.1 *circular ring bridge element, n*—an external skeletal fixator component as described in Annex A1, which is circular, or may be assembled from several components to form a circular element, lies in a single plane, and has one center or curvature.

A3.3.1.2 *ring segment bridge element, n*—an external skeletal fixator component as described in Annex A1, which consists of a single ring segment, or is assembled from several components to form a ring segment, lies in a single plane, has one center of curvature, and whose arc spans 180° or more, but less than 360°.

A3.3.1.3 *test component, n*—a complete or assembled *circular ring bridge element* or *ring segment bridge element* prepared for testing according to A3.8.1 and A3.8.2.

#### A3.4 Summary of Test Method

A3.4.1 Complete circular ring elements (either a single component or an assembly of components to form a complete circular ring) or a ring segment ( $\geq 180^\circ$  arc) are obtained for testing. In-plane compressive forces are applied quasistatically to the circular ring or ring segment, so that the load application points are 180° apart, measured along the arc of the ring. If appropriate, load is increased until part failure occurs. A graphical plot of load versus displacement is used to determine in-plane compressive strength and stiffness.

#### A3.5 Significance and Use

A3.5.1 This test method is used to measure the compressive strength and stiffness of circular ring or ring segment bridge elements of external skeletal fixators when loaded in the plane of the ring. The results obtained in this test are not intended to predict the clinical efficacy or safety of the tested products. This test method is intended only to measure the uniformity of the products tested or to compare the mechanical properties of different products.

A3.5.2 This test method may not be appropriate for all types of fixator applications. The user is cautioned to consider the appropriateness of the method in view of the materials being tested and their potential application.

#### A3.6 Apparatus

A3.6.1 *Pin and Clevis Fixture*—A U-shaped metal lug (“clevis”) with a hole drilled across both legs of the “U” to accommodate a clearance fit steel pin. The opposite end of the Clevis is attached to the grip of the load frame. The pin diameter should be of the approximate size of the holes in the test components, if applicable; or, if a hole must be drilled for testing, the pin shall be no greater than half the width of the test component at the point of load application.

A3.6.2 *Shims*—Metallic flat washers of varying specified thickness, which will fit over the pin and between the sides of the clevis and the test component.

A3.6.3 *Torquemeter*—An electronic, or mechanical device, or both, which is capable of measuring torque applied to a screw or bolt.

A3.6.4 *Load Frame*—Machines used for testing shall conform to the requirements of Practices E 4. The loads used for the test shall be within the loading range of the test machine as defined in Practices E 4.

A3.6.5 *Recording Device*—A suitable recorder to plot a graph of load versus load frame displacement on perpendicular axes.

#### A3.7 Test Specimen

A3.7.1 All test components, including connection components, shall be representative of clinical quality products.

A3.7.2 If one or more of the elements to be tested has been used previously, the nature of such prior usage should be appropriately described.

A3.7.3 The test component, when assembled (if applicable), shall form a full or partial ring in a single plane, with a single center of curvature.