



Designation: D 6117 – 97

Standard Test Methods for Mechanical Fasteners in Plastic Lumber and Shapes¹

This standard is issued under the fixed designation D 6117; the number immediately following the designation indicates the year of original adoption or, in the case of revision, the year of last revision. A number in parentheses indicates the year of last reapproval. A superscript epsilon (ϵ) indicates an editorial change since the last revision or reapproval.

INTRODUCTION

The use of plastic lumber and shapes often involves the use of mechanical fasteners, such as nails, screws, bolts, lag screws, and connectors. Data on the strength and performance of such fasteners are frequently needed for design and for comparative purposes. Presented herewith are methods of conducting tests for nail, staple and screw withdrawal resistance and lateral load transmission by nail, staple, screw, and bolt. The use of standard methods for these tests is recommended as a means of obtaining comparable data and of eliminating variables in test results because of variation in testing methods.

1. Scope

1.1 These test methods cover the evaluation of fastener use with “as manufactured” plastic lumber and shapes through the use of two different testing procedures.

1.2 The test methods appear in the following order:

	Sections
Test Method A—Nail, Staple, or Screw Withdrawal Test	4 to 13
Test Method B—Lateral Nail, Staple, or Screw Resistance Test	14 to 22

1.3 Plastic lumber and plastic shapes are currently made predominately from recycled plastics. However, this test method would also be applicable to similar manufactured plastic products made from virgin resins where the product is non-homogeneous in the cross-section.

1.4 The values stated in inch-pound units are to be regarded as the standard. The SI units given in parentheses are for information only.

1.5 *This standard does not purport to address all of the safety concerns, if any, associated with its use. It is the responsibility of the user of this standard to establish appropriate safety and health practices and determine the applicability of regulatory limitations prior to use.*

NOTE 1—There is no similar or equivalent ISO standard.

2. Referenced Documents

2.1 *ASTM Standards:*

D 833 Terminology Relating to Plastics²

D 1761 Test Methods for Mechanical Fasteners in Wood³

D 5033 Guide for the Development of Standards Relating to the Proper Use of Recycled Plastics⁴

D 6111 Test Method for Bulk Density and Specific Gravity of Plastic Lumber and Shapes by Displacement⁴

E 4 Practices for Load Verification of Testing Machines⁵

2.2 *ANSI Standards:*

ANSI B18.61 American National Standard for Slotted and Head Wood Screws⁶

3. Terminology

3.1 *Definitions:*

3.1.1 *plastic lumber, n*—a manufactured product composed of more than 50 weight percent resin, and in which the product generally is rectangular in cross-section and typically supplied in board and dimensional lumber sizes, may be filled or unfilled, and may be composed of single or multiple resin blends.

3.1.2 *plastic shape, n*—manufactured product composed of more than 50 weight percent resin, and in which the product generally is not rectangular in cross-section, may be filled or unfilled, and may be composed of single or multiple resin blends.

3.1.3 *resin, n*—a solid or pseudosolid organic material often of high molecular weight, which exhibits a tendency to flow when subjected to stress, usually has a softening or melting range, and usually fractures conchoidally. (See Terminology D 883.)

3.1.3.1 *Discussion*—In a broad sense, the term is used to designate any polymer that is basic material for plastics.

¹ These test methods are under the jurisdiction of ASTM Committee D-20 on Plastics and are the direct responsibility of Subcommittee D20.20 on Plastic Products (Section D20.20.01).

Current edition approved April 10, 1997. Published February 1998.

² *Annual Book of ASTM Standards*, Vol 08.01.

³ *Annual Book of ASTM Standards*, Vol 04.10.

⁴ *Annual Book of ASTM Standards*, Vol 08.03.

⁵ *Annual Book of ASTM Standards*, Vol 03.01.

⁶ Available from American National Standards Institute, 11 W. 42nd St., 13th Floor, New York, NY 10036.

3.2 Additional definition of terms applying to this test method appear in Terminology D 833 and Guide D 5033.

TEST METHOD A—NAIL, STAPLE, OR SCREW WITHDRAWAL TEST

4. Scope

4.1 This test method provides a basic procedure for evaluating the resistance of plastic lumber and shapes materials to direct withdrawal of nails, staples, and screws. Spikes are included as nails in this standard.

4.2 This test method also provides a basis for determining comparable performance of different types and sizes of nails, staples, and screws in direct withdrawal from plastic lumber and shapes.

5. Summary of Test Method

5.1 Specimens consist of “as manufactured” plastic lumber and shapes, with nails, staples, or screws driven at right angles to one or more faces. The fasteners are withdrawn at a uniform rate of speed by means of a testing machine, and the maximum load is recorded. Supplementary physical properties of the plastic lumber and shapes are also determined.

6. Significance and Use

6.1 The resistance of plastic lumber and shapes to direct withdrawal of nails, staples, or screws is a measure of its ability to hold or be held to an adjoining object by means of such fasteners. Factors that affect this withdrawal resistance include the physical and mechanical properties of the plastic lumber and shapes; the size, shape, and surface condition of the fasteners; the speed of withdrawal; physical changes to plastic lumber and shapes or fasteners between time of driving and time of withdrawal; orientation of fiber axis; the occurrence and nature of prebored lead holes; and the temperatures during insertion and withdrawal. These factors will be as circumstances dictate, and representative of the normal manufacturing process.

6.2 By using a standard size and type of nail, staple, or screw, withdrawal resistance of plastic lumber and shapes can be determined. Throughout the method this is referred to as the basic withdrawal test. Similarly, comparative performances of different sizes or types of nail, staple, or screw can be determined by using a standard procedure with a particular plastic lumber and shape, which eliminates the plastic lumber and shapes product as a variable. Since differences in test methods can have considerable influence on results, it is important that a standard procedure be specified and adhered to, if test values are to be related to other test results.

7. Apparatus

7.1 *Testing Machine*—Any suitable testing machine that is capable of operation at a constant rate of motion of the movable head and has an accuracy of $\pm 1\%$ when calibrated in accordance with Test Methods E 4.

7.2 *Grips*—A gripping device shaped to fit the base of the fastener head and of such a design as to allow accurate clamping assembly that will hold the specimen to one platen of

the machine is also required. A suitable test mechanism for screw withdrawal is illustrated in Fig. 1.

8. Test Nails, Staples, or Screws

8.1 Nails:

8.1.1 Nails used for basic withdrawal tests shall be diamond-point round-wire, low-carbon-steel nails nominally 0.148 in. (3.76 mm) in diameter and 3 in. (76 mm) in length (See Note 2). Use each nail only once.

NOTE 2—A 10d galvanized common steel wire nail meets this requirement.

8.1.2 For determining holding ability of different sizes or types of nails in plastic lumber and shapes, the respective sizes and types of nail will be as circumstances dictate. These nails shall be representative of the normal manufacturing process, and special cleaning of the shank shall normally not be undertaken.

8.2 Staples:

8.2.1 Staples used for basic leg withdrawal resistance shall be nominally 2.0 in. (51 mm) long, $\frac{7}{16}$ in. (11 mm) crown, 15 gage (0.072 in.) (1.83 mm) galvanized steel staples. Use each staple only once.

8.2.2 For determining holding ability of different types or sizes of staples in plastic lumber and shapes, the respective staples shall be representative of the normal manufacturing process, and special cleaning of the legs shall not normally be undertaken.

8.3 Screws:

8.3.1 Screws used for basic withdrawal tests shall be nominally 1-in. (25-mm) No. 10-gage flathead low-carbon-steel wood screws as described in ANSI B18.6.1. Use each screw only once.

8.3.2 For determining holding ability of different sizes and types of screws in plastic lumber and shapes, the respective size and types of screw will be as circumstances dictate. These screws shall be representative of the normal manufacturing process.

9. Sampling

9.1 Sampling should provide for selection of representative test materials on an objective and unbiased basis, covering an appropriate range in density and properties as circumstances suggest.

9.2 The tests should be sufficiently extensive to provide reliable results. Where analysis by statistical procedures is contemplated, experience and sometimes advance estimates can be used to establish the scope of testing and type of sampling needed to achieve the expected reliability.

NOTE 3—The precision required, and thus the manner of sampling and number of tests, will depend upon specific objectives. No specific criteria therefore can be established. General experience indicates that the coefficient of variation from tests of fasteners ranges from about 15 to 30 %. When such is the case, precision of 5 to 10 %, with 95 % confidence (an often accepted general measure of reliability for testing of wood products) cannot be achieved without making a rather large number of tests. The present recommendation is to make at least ten replications for each variable as a minimum requirement.

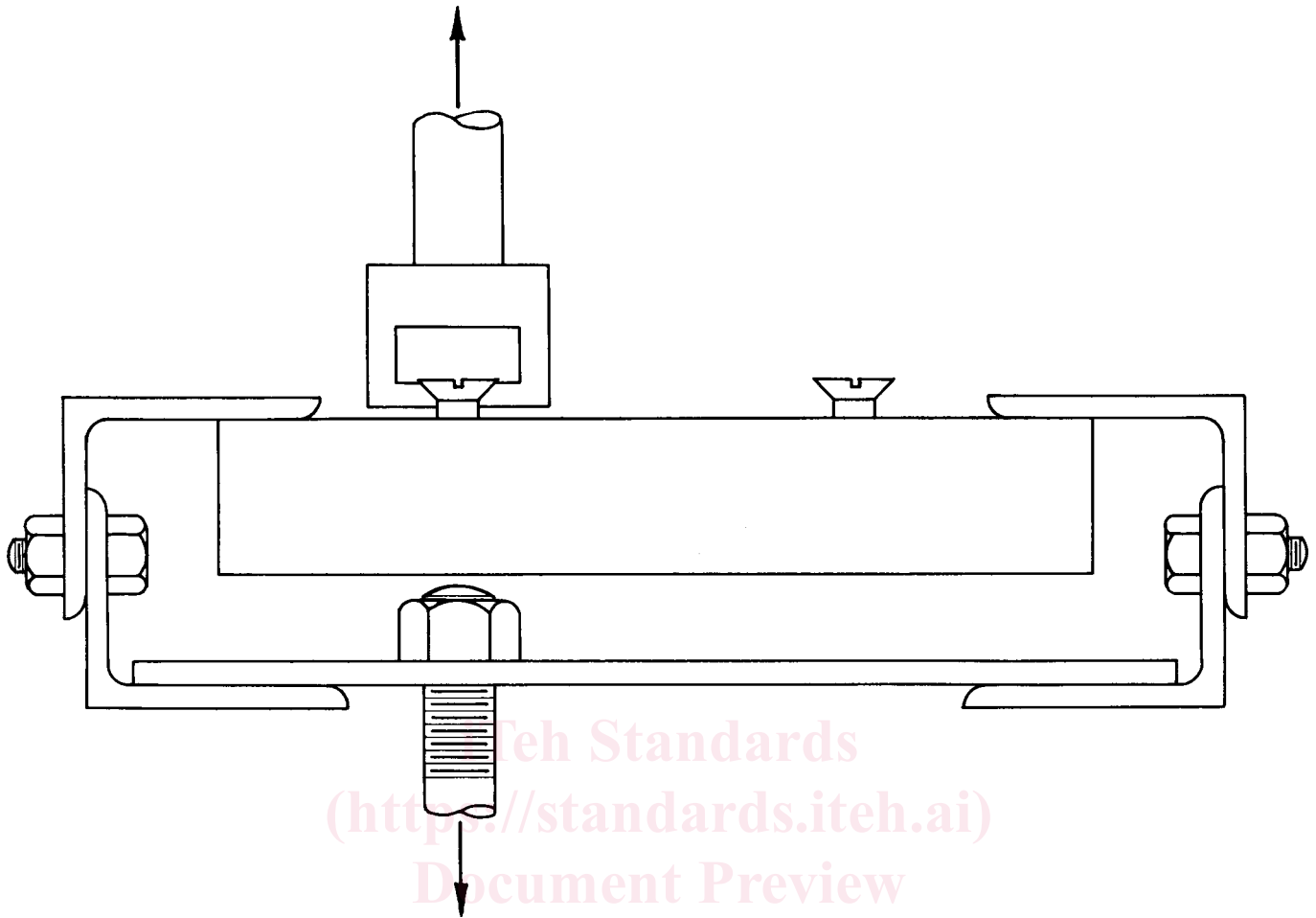

FIG. 1 Diagram of Assembly for Screw Withdrawal Test

ASTM D6117-97

10. Test Specimen

10.1 Nail and Staple Withdrawal

10.1.1 For basic withdrawal tests from plastic lumber, cut the test specimens to length from the “as manufactured” profile. Drive nails of the type outlined in 8.1.1 and staples of the type outlined in 8.2.1 at right angles to the face of the specimen to a minimum total penetration of 1¼ in. (32 mm). With the specimen oriented in a flatwise (plank) position, drive two fasteners into the top face (width), two into the side face (height), and one into each end. End and edge distances shall be sufficient to avoid splitting. In general, edge distances should not be less than 1½ in. (38 mm) and two fasteners shall not be driven in line with each other or less than 2 in. (50 mm) apart on the top and side faces. Drive nails manually with a hammer. Insert staples with an appropriate tool, as nearly as possible perpendicular to the specimen surface, with the staple crown at a 45° (±10°) angle to the axial dimension of the specimen.

10.1.2 For basic withdrawal tests from plastic shapes, the test specimen shall be a single thickness of the “as manufactured” product. Drive nails of the type outlined in 8.1.1 through the specimen at right angles to the face, permitting at least ½ in. (13 mm) of the shank portion to remain above the surface. Drive nails manually by means of a hammer. Insert staples with

an appropriate tool as in 10.1.1, with the staple crown oriented at a 45° (±10°) angle to the axial dimension of the specimen.

10.1.3 For determining the withdrawal resistance of particular sizes and shapes of nails or staples in plastic lumber and shapes, the specimen shall be of convenient size to accommodate the quantity of fasteners to be tested in each specimen, without exceeding the edge and end distances and spacing necessary to avoid splitting. In plastic lumber and shapes, drive fasteners to 70 % of their length; in plastic lumber and shapes less than 1 in. (25mm) thick, drive them completely through the thickness with at least ½ in. (13 mm) of the shank portion remaining above the surface. Drive the fasteners by the method intended to be used in practice, that is, either manually with a hammer, or with an applicator or appropriate tool if this is the normal method.

10.1.3.1 If the withdrawal resistance may be influenced by the material in which the fastener is to be driven, drive the fastener through the fastened member (cleat) into the base fastening member.

10.2 Screw Withdrawal:

10.2.1 For basic withdrawal tests from plastic lumber, cut the test specimens to length from the “as manufactured” profile. With the specimen oriented in a flatwise (plank) position, thread two screws of the type outlined in 8.3.1 into