

---

---

**Geotechnical investigation and  
testing — Laboratory testing of soil —  
Part 9:  
Consolidated triaxial compression  
tests on water saturated soils**

**iTeh STANDARD PREVIEW**  
*Reconnaissance et essais géotechniques — Essais de laboratoire sur  
les sols —*  
**(standards.iteh.ai)**

*Partie 9: Essais en compression à l'appareil triaxial consolidés sur  
sols saturés*

ISO 17892-9:2018

[https://standards.iteh.ai/catalog/standards/sist/c5a9bce9-2b34-4917-bbbf-  
edf76b6c97eb/iso-17892-9-2018](https://standards.iteh.ai/catalog/standards/sist/c5a9bce9-2b34-4917-bbbf-edf76b6c97eb/iso-17892-9-2018)



**iTeh STANDARD PREVIEW**  
**(standards.iteh.ai)**

ISO 17892-9:2018

<https://standards.iteh.ai/catalog/standards/sist/c5a9bce9-2b34-4917-bbbf-edf76b6c97eb/iso-17892-9-2018>



**COPYRIGHT PROTECTED DOCUMENT**

© ISO 2018

All rights reserved. Unless otherwise specified, or required in the context of its implementation, no part of this publication may be reproduced or utilized otherwise in any form or by any means, electronic or mechanical, including photocopying, or posting on the internet or an intranet, without prior written permission. Permission can be requested from either ISO at the address below or ISO's member body in the country of the requester.

ISO copyright office  
CP 401 • Ch. de Blandonnet 8  
CH-1214 Vernier, Geneva  
Phone: +41 22 749 01 11  
Fax: +41 22 749 09 47  
Email: [copyright@iso.org](mailto:copyright@iso.org)  
Website: [www.iso.org](http://www.iso.org)

Published in Switzerland

# Contents

	Page
<b>Foreword</b> .....	<b>v</b>
<b>Introduction</b> .....	<b>vi</b>
<b>1 Scope</b> .....	<b>1</b>
<b>2 Normative references</b> .....	<b>1</b>
<b>3 Terms and definitions</b> .....	<b>2</b>
<b>4 Symbols</b> .....	<b>3</b>
<b>5 Apparatus</b> .....	<b>5</b>
5.1 General.....	5
5.2 Triaxial cell.....	7
5.3 Confining membrane.....	7
5.4 Porous discs.....	7
5.5 Filter paper.....	8
5.6 Pressure systems.....	8
5.7 Load frame.....	8
5.8 Measuring devices.....	8
5.8.1 Load measuring device.....	8
5.8.2 Pressure measuring devices.....	9
5.8.3 Vertical displacement measuring device.....	9
5.8.4 Volume change measuring device.....	9
5.9 Cell and back pressure fluids.....	9
5.10 Ancillary apparatus.....	9
<b>6 Test procedure</b> .....	<b>10</b>
6.1 General requirements and equipment preparation.....	10
6.2 Preparation of specimens.....	10
6.3 Saturation of specimen.....	11
6.3.1 Saturation.....	11
6.3.2 Application of cell and back pressure.....	12
6.3.3 Saturation checks.....	12
6.4 Isotropic consolidation (CIU and CID tests).....	13
6.5 Anisotropic consolidation (CAU and CAD tests).....	13
6.6 End of consolidation.....	13
6.7 Shearing.....	13
6.7.1 General.....	13
6.7.2 Undrained tests (CIU and CAU).....	14
6.7.3 Drained tests (CID and CAD).....	14
6.8 Dismounting.....	15
<b>7 Test results</b> .....	<b>15</b>
7.1 Bulk density, dry density and water content.....	15
7.2 Calculations of test parameters.....	16
7.2.1 Height after consolidation.....	16
7.2.2 Corrected cross sectional area.....	16
7.2.3 Corrections for elastic membrane.....	16
7.2.4 Correction for filter paper strips.....	17
7.2.5 Vertical total stress.....	17
7.2.6 Vertical effective stress.....	17
7.2.7 Horizontal total stress.....	18
7.2.8 Horizontal effective stress.....	18
7.2.9 Pore pressure change.....	18
7.2.10 Vertical strain.....	18
7.2.11 Vertical strain during shear.....	18
7.2.12 Volumetric strain.....	18
7.2.13 Volumetric strain during shear.....	18

<b>8</b>	<b>Test report</b> .....	<b>19</b>
8.1	Mandatory reporting.....	19
8.2	Graphical presentation.....	20
8.3	Optional reporting.....	20
	<b>Annex A (normative) Calibration, maintenance and checks</b> .....	<b>21</b>
	<b>Annex B (informative) Additional calculations for effective shear strength</b> .....	<b>23</b>
	<b>Bibliography</b> .....	<b>25</b>

**iTeh STANDARD PREVIEW**  
**(standards.iteh.ai)**

[ISO 17892-9:2018](https://standards.iteh.ai/catalog/standards/sist/c5a9bce9-2b34-4917-bbbf-edf76b6c97eb/iso-17892-9-2018)

<https://standards.iteh.ai/catalog/standards/sist/c5a9bce9-2b34-4917-bbbf-edf76b6c97eb/iso-17892-9-2018>

## Foreword

ISO (the International Organization for Standardization) is a worldwide federation of national standards bodies (ISO member bodies). The work of preparing International Standards is normally carried out through ISO technical committees. Each member body interested in a subject for which a technical committee has been established has the right to be represented on that committee. International organizations, governmental and non-governmental, in liaison with ISO, also take part in the work. ISO collaborates closely with the International Electrotechnical Commission (IEC) on all matters of electrotechnical standardization.

The procedures used to develop this document and those intended for its further maintenance are described in the ISO/IEC Directives, Part 1. In particular the different approval criteria needed for the different types of ISO documents should be noted. This document was drafted in accordance with the editorial rules of the ISO/IEC Directives, Part 2 (see [www.iso.org/directives](http://www.iso.org/directives)).

Attention is drawn to the possibility that some of the elements of this document may be the subject of patent rights. ISO shall not be held responsible for identifying any or all such patent rights. Details of any patent rights identified during the development of the document will be in the Introduction and/or on the ISO list of patent declarations received (see [www.iso.org/patents](http://www.iso.org/patents)).

Any trade name used in this document is information given for the convenience of users and does not constitute an endorsement.

For an explanation on the voluntary nature of standards, the meaning of ISO specific terms and expressions related to conformity assessment, as well as information about ISO's adherence to the World Trade Organization (WTO) principles in the Technical Barriers to Trade (TBT) see the following URL: [www.iso.org/iso/foreword.html](http://www.iso.org/iso/foreword.html).

This document was prepared by the European Committee for Standardization (CEN) Technical Committee CEN/TC 341, *Geotechnical investigation and testing*, in collaboration with ISO Technical Committee TC 182, *Geotechnics*, in accordance with the agreement on technical cooperation between ISO and CEN (Vienna Agreement).

This first edition of ISO 17892-9 cancels and replaces ISO/TS 17892-9:2004, which has been technically revised. It also incorporates ISO/TS 17892-9:2004/Cor.1:2006.

A list of all the parts in the ISO 17892 series can be found on the ISO website.

## Introduction

This document covers areas in the international field of geotechnical engineering never previously standardised. It is intended that this document presents broad good practice throughout the world and significant differences with national documents is not anticipated. It is based on international practice (see Reference [1]).

## iTeh STANDARD PREVIEW (standards.iteh.ai)

ISO 17892-9:2018

<https://standards.iteh.ai/catalog/standards/sist/c5a9bce9-2b34-4917-bbbf-edf76b6c97eb/iso-17892-9-2018>

# Geotechnical investigation and testing — Laboratory testing of soil —

## Part 9: Consolidated triaxial compression tests on water saturated soils

### 1 Scope

This document specifies a method for consolidated triaxial compression tests on water-saturated soils.

This document is applicable to the laboratory determination of triaxial shear strength under compression loading within the scope of geotechnical investigations.

The cylindrical specimen, which can comprise undisturbed, re-compacted, remoulded or reconstituted soil, is subjected to an isotropic or an anisotropic stress under drained conditions and thereafter is sheared under undrained or drained conditions. The test allows the determination of shear strength, stress-strain relationships and effective stress paths. All stresses and strains are denoted as positive numerical values in compression.

NOTE 1 This document provides a test for a single specimen. A set of at least three relateable tests are required to determine the shear strength parameters from these tests. Procedures for evaluating the results are included in [Annex B](#) and, where required, the shear strength parameters are to be included in the report.

Special procedures such as:

- a) tests with lubricated ends;
- b) multi-stage tests;
- c) tests with zero lateral strain ( $K_0$ ) consolidation;
- d) tests with local measurement of strain or local measurement of pore pressure;
- e) tests without rubber membranes;
- f) extension tests;
- g) shearing where cell pressure varies,

are not fully covered in this procedure. However, these specific tests can refer to general procedures described in this document.

NOTE 2 This document fulfils the requirements of consolidated triaxial compression tests for geotechnical investigation and testing in accordance with EN 1997-1 and EN 1997-2.

### 2 Normative references

The following documents are referred to in the text in such a way that some or all of their content constitutes requirements of this document. For dated references, only the edition cited applies. For undated references, the latest edition of the referenced document (including any amendments) applies.

ISO 14688-1, *Geotechnical investigation and testing — Identification and classification of soil — Part 1: Identification and description*

## ISO 17892-9:2018(E)

ISO 17892-1, *Geotechnical investigation and testing — Laboratory testing of soil — Part 1: Determination of water content*

ISO 17892-2, *Geotechnical investigation and testing — Laboratory testing of soil — Part 2: Determination of bulk density*

ISO 17892-3, *Geotechnical investigation and testing — Laboratory testing of soil — Part 3: Determination of particle density*

### 3 Terms and definitions

For the purposes of this document, the following terms and definitions apply.

ISO and IEC maintain terminological databases for use in standardization at the following addresses:

- IEC Electropedia: available at <https://www.electropedia.org/>
- ISO Online browsing platform: available at <https://www.iso.org/obp>

#### 3.1

##### **CIU-test**

isotropically consolidated undrained test

#### 3.2

##### **CAU-test**

anisotropically consolidated undrained test

#### 3.3

##### **CID-test**

isotropically consolidated drained test

#### 3.4

##### **CAD-test**

anisotropically consolidated drained test

#### 3.5

##### **pore pressure**

pressure of water in the void space within the soil specimen

#### 3.6

##### **back pressure**

external pressure by which the pore pressure is increased prior to consolidation or shearing to ensure saturation

#### 3.7

##### **cell pressure**

pressure applied to the cell fluid

#### 3.8

##### **deviator stress**

difference between the vertical total stress and the horizontal total stress

#### 3.9

##### **effective stress**

difference between the total stress and pore pressure

#### 3.10

##### **failure**

stress or strain condition at which one of the following criteria are met:

- peak deviator stress

ITeH STANDARD PREVIEW  
(standards.iteh.ai)

ISO 17892-9:2018

<https://standards.iteh.ai/catalog/standards/sist/c5a9bce9-2b34-4917-bbbf-edf76b6c97eb/iso-17892-9-2018>



- peak effective stress ratio i.e. the ratio between the vertical and horizontal effective stress
- a specified deformation criterion e.g. 10 % vertical strain
- other definitions if required

## 4 Symbols

$A_i$	initial cross sectional area of the specimen
$A_{cor}$	cross-sectional area of the specimen at any point in time
$a$	cross-sectional area of the piston if an external load cell is used
$B$	pore pressure coefficient i.e. the ratio of the increase in pore pressure, $\Delta u$ resulting from an increment of cell pressure, $\Delta \sigma_c$ under undrained conditions
$D_c$	specimen diameter at the end of consolidation
$D_i$	initial specimen diameter
$D_m$	initial internal diameter of the confining membrane (before it is placed on specimen)
$E_m$	elastic modulus of the confining membrane
$F$	factor for calculating the rate of displacement of the load frame
$f$	factor relating the vertical strain to the specimen volumetric strain
$H_c$	specimen height at the end of consolidation
$H_i$	initial height of specimen
$h$	distance from the top of the top cap to the mid-height of the specimen
$K_{fp}$	load (when fully mobilized) carried by filter paper covering a unit length of the specimen perimeter
$P$	vertical load reading
$P_{fp}$	fraction of perimeter covered by filter paper
$t_m$	initial thickness of the unstressed membrane
$t_{50}$	time required for 50 % primary consolidation to take place
$t_{100}$	time required for 100 % primary consolidation to take place
$u$	pore pressure at the mid height of the specimen
$u_B$	back pressure (i.e. the pore pressure at start of shearing)
$V_i$	initial volume of specimen
$v_{max}$	rate of vertical displacement of the load frame during shearing
$W$	gravity force acting on the sum of the deadweight hanger (if used), the piston, the top cap and one half of the soil specimen
$\Delta H$	specimen change in height (with compression being a positive numerical value)

$\Delta H_c$	vertical change in height during consolidation, including any vertical change in height during saturation, if measured
$\Delta u$	change in pore pressure at the mid height of the specimen
$\Delta V$	specimen volume change (with a reduction in volume being a positive numerical value)
$\Delta V_c$	volume change up to the end of consolidation
$\Delta \sigma_c$	change in cell pressure
$(\Delta \sigma_h)_m$	correction to horizontal total stress due to membrane restraint
$(\Delta \sigma_v)_{fp}$	correction to vertical total stress due to restraint of the filter paper
$(\Delta \sigma_v)_m$	correction to vertical total stress due to membrane restraint
$\gamma$	unit weight of the cell fluid
$\varepsilon$	strain (with compression being a positive numerical value)
$\varepsilon_{sv}$	vertical strain during shear (expressed as a ratio)
$\varepsilon_{svol}$	volumetric strain during shear (expressed as a ratio)
$\varepsilon_v$	vertical strain (expressed as a ratio)
$\varepsilon_{vf}$	expected vertical strain at failure (expressed as a ratio)
$(\varepsilon_v)_m$	vertical strain of the membrane (expressed as a ratio)
$\varepsilon_{vol}$	volumetric strain
$(\varepsilon_{vol})_m$	volumetric strain of the volume enclosed by the membrane (expressed as a ratio)
$\sigma_c$	cell pressure
$\sigma_h$	horizontal total stress at the mid height of the specimen (see note)
$\sigma'_h$	horizontal effective stress at the mid height of the specimen (see note)
$\sigma'_{hc}$	horizontal effective stress at the mid height of the specimen at the end of consolidation
$\sigma_v$	vertical total stress at the mid height of the specimen (see note)
$\sigma'_v$	vertical effective stress at the mid height of the specimen (see note)
$\sigma_v - \sigma_h$	deviator stress
$(\sigma'_v - 2\sigma'_h)/3$	mean effective stress
$\sigma'_{vc}$	vertical effective stress at the mid height of the specimen at the end of consolidation

NOTE Throughout this document, effective stresses are indicated by a prime. Vertical and horizontal directions are indicated by the suffixes “v” and “h” respectively. This convention ensures that the directions of the action of stress acting on the specimen are clear and independent of their relative magnitudes.

## 5 Apparatus

### 5.1 General

The equipment shall undergo regular calibration, maintenance and checks as specified in [Annex A](#).

A schematic diagram of a typical apparatus for triaxial compression testing is shown in [Figure 1](#).

**iTeh STANDARD PREVIEW**  
**(standards.iteh.ai)**

ISO 17892-9:2018

<https://standards.iteh.ai/catalog/standards/sist/c5a9bce9-2b34-4917-bbbf-edf76b6c97eb/iso-17892-9-2018>

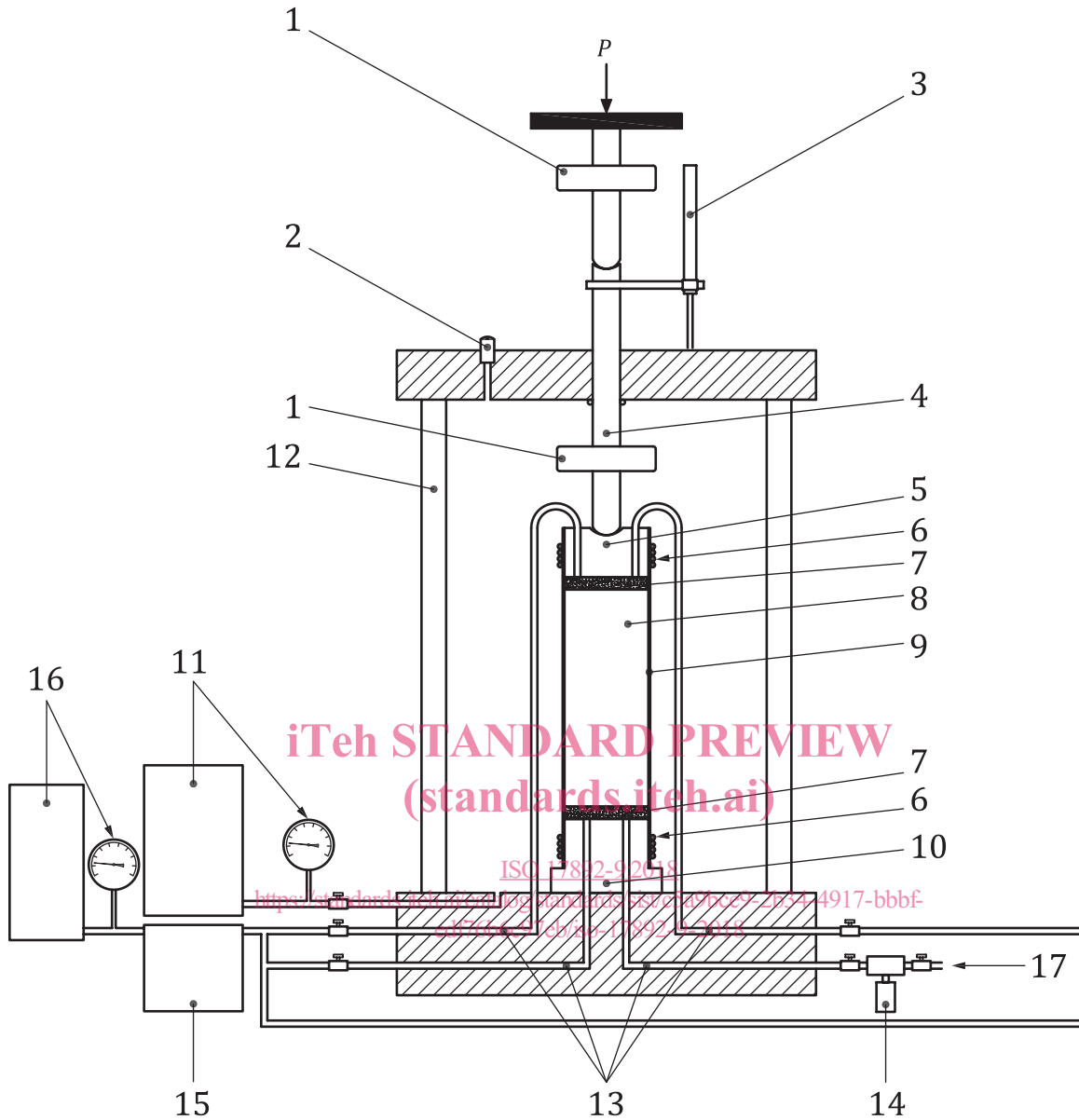

**Key**

- |   |   |          |   |
|---|---|----------|---|
| 1 | alternative positions for load measuring device | 10       | pedestal  |
| 2 | air bleed                                       | 11       | device for measurement and control of cell pressure |
| 3 | vertical displacement measuring device          | 12       | triaxial cell                                       |
| 4 | piston  | 13       | drainage tubes                                      |
| 5 | top cap   | 14       | pore pressure sensor                                |
| 6 | O-rings   | 15       | device for measurement of volume change             |
| 7 | porous disc                                     | 16       | device for measurement and control of back pressure |
| 8 | soil specimen                                   | 17       | flushing system                                     |
| 9 | membrane (with or without side drains)          | <i>P</i> | vertical load                                       |

**Figure 1 — Schematic diagram of a typical triaxial apparatus**