

---

---

**Rubber — Measurement of  
vulcanization characteristics using  
curemeters —**

**Part 3:  
Rotorless curemeter**

**iTeh STANDARD PREVIEW**  
*Caoutchouc — Mesure des caractéristiques de vulcanisation à l'aide  
de rhéomètres —  
(standards.iteh.ai)  
Partie 3: Rhéomètre sans rotor*

ISO 6502-3:2018

<https://standards.iteh.ai/catalog/standards/sist/56d1d11b-a15d-43cb-9824-bcb4eff73769/iso-6502-3-2018>



**iTeh STANDARD PREVIEW**  
**(standards.iteh.ai)**

ISO 6502-3:2018

<https://standards.iteh.ai/catalog/standards/sist/56d1d11b-a15d-43cb-9824-bcb4eff73769/iso-6502-3-2018>



**COPYRIGHT PROTECTED DOCUMENT**

© ISO 2018

All rights reserved. Unless otherwise specified, or required in the context of its implementation, no part of this publication may be reproduced or utilized otherwise in any form or by any means, electronic or mechanical, including photocopying, or posting on the internet or an intranet, without prior written permission. Permission can be requested from either ISO at the address below or ISO's member body in the country of the requester.

ISO copyright office  
CP 401 • Ch. de Blandonnet 8  
CH-1214 Vernier, Geneva  
Phone: +41 22 749 01 11  
Fax: +41 22 749 09 47  
Email: [copyright@iso.org](mailto:copyright@iso.org)  
Website: [www.iso.org](http://www.iso.org)

Published in Switzerland

# Contents

	Page
Foreword .....	iv
<b>1 Scope</b> .....	<b>1</b>
<b>2 Normative references</b> .....	<b>1</b>
<b>3 Terms and definitions</b> .....	<b>1</b>
<b>4 Principle</b> .....	<b>1</b>
<b>5 Apparatus</b> .....	<b>2</b>
5.1 General .....	2
5.2 Dies .....	6
5.2.1 Seal plate .....	7
5.2.2 Seal .....	7
5.3 Die closure .....	7
5.4 Oscillation system .....	8
5.5 Torque-measuring system .....	8
5.6 Protective films .....	8
5.7 Heating and temperature control .....	8
<b>6 Calibration</b> .....	<b>9</b>
<b>7 Test piece</b> .....	<b>9</b>
<b>8 Vulcanization temperature</b> .....	<b>9</b>
<b>9 Conditioning</b> .....	<b>9</b>
<b>10 Procedure</b> .....	<b>9</b>
10.1 Preparation for test .....	9
10.2 Loading the curemeter .....	10
<b>11 Expression of results</b> .....	<b>10</b>
11.1 General .....	10
11.2 Torque values .....	10
11.3 Scorch time .....	10
11.4 Time to a percentage of full cure .....	10
11.5 Cure rate index .....	11
<b>12 Precision</b> .....	<b>11</b>
<b>13 Test report</b> .....	<b>11</b>
<b>Annex A (normative) Calibration schedule</b> .....	<b>12</b>
<b>Annex B (informative) Practical examples of calibration for the various curemeters</b> .....	<b>14</b>
<b>Annex C (informative) Precision</b> .....	<b>17</b>
<b>Bibliography</b> .....	<b>20</b>

ITeH STANDARD PREVIEW  
 (standards.iteh.ai)

<https://standards.iteh.ai/catalog/standards/sist/56d1d11b-a15d-43cb-9824-bcb4ef73769/iso-6502-3-2018>

## Foreword

ISO (the International Organization for Standardization) is a worldwide federation of national standards bodies (ISO member bodies). The work of preparing International Standards is normally carried out through ISO technical committees. Each member body interested in a subject for which a technical committee has been established has the right to be represented on that committee. International organizations, governmental and non-governmental, in liaison with ISO, also take part in the work. ISO collaborates closely with the International Electrotechnical Commission (IEC) on all matters of electrotechnical standardization.

The procedures used to develop this document and those intended for its further maintenance are described in the ISO/IEC Directives, Part 1. In particular, the different approval criteria needed for the different types of ISO documents should be noted. This document was drafted in accordance with the editorial rules of the ISO/IEC Directives, Part 2 (see [www.iso.org/directives](http://www.iso.org/directives)).

Attention is drawn to the possibility that some of the elements of this document may be the subject of patent rights. ISO shall not be held responsible for identifying any or all such patent rights. Details of any patent rights identified during the development of the document will be in the Introduction and/or on the ISO list of patent declarations received (see [www.iso.org/patents](http://www.iso.org/patents)).

Any trade name used in this document is information given for the convenience of users and does not constitute an endorsement.

For an explanation of the voluntary nature of standards, the meaning of ISO specific terms and expressions related to conformity assessment, as well as information about ISO's adherence to the World Trade Organization (WTO) principles in the Technical Barriers to Trade (TBT) see the following URL: [www.iso.org/iso/foreword.html](http://www.iso.org/iso/foreword.html). (standards.iteh.ai)

This document was prepared by Technical Committee ISO/TC 45, *Rubber and rubber products*, Subcommittee SC 2, *Testing and analysis*. ISO 6502-3:2018

<https://standards.iteh.ai/catalog/standards/sist/56d1d11b-a15d-43cb-9824-b1e48737f01e/iso-6502-3>

A list of all parts in the ISO 6502 series can be found on the ISO website.

Any feedback or questions on this document should be directed to the user's national standards body. A complete listing of these bodies can be found at [www.iso.org/members.html](http://www.iso.org/members.html).

# Rubber — Measurement of vulcanization characteristics using curemeters —

## Part 3: Rotorless curemeter

**WARNING 1** — Persons using this document should be familiar with normal laboratory practice. This document does not purport to address all of the safety problems, if any, associated with its use. It is the responsibility of the user to establish appropriate safety and health practices and to determine applicability of any other restrictions.

**WARNING 2** — Certain procedures specified in this document might involve the use or generation of substances, or the generation of waste, that could constitute a local environmental hazard. Reference should be made to appropriate documentation on safe handling and disposal after use.

### 1 Scope

This document specifies a method for determining selected vulcanization characteristics of a rubber compound by means of a rotorless curemeter. The introduction to the use of curemeters is given in ISO 6502-1.

### 2 Normative references

The following documents are referred to in the text in such a way that some or all of their content constitutes requirements of this document. For dated references, only the edition cited applies. For undated references, the latest edition of the referenced document (including any amendments) applies.

ISO 6502-1:2018, *Rubber — Measurement of vulcanization characteristics using curemeters — Part 1: Introduction*

ISO 18899:2013, *Rubber — Guide to the calibration of test equipment*

### 3 Terms and definitions

For the purposes of this document, the terms and definitions given in ISO 6502-1 apply.

ISO and IEC maintain terminological databases for use in standardization at the following addresses:

- ISO Online browsing platform: available at <https://www.iso.org/obp>
- IEC Electropedia: available at <http://www.electropedia.org/>

### 4 Principle

A test piece of rubber is placed in a heated cavity formed by two dies, one of which is oscillated at a given frequency and amplitude. This action exerts a shear strain on the test piece and a shear torque which depends on the stiffness (shear modulus) of the rubber. The torque that increases as vulcanization proceeds is measured by a torque sensor incorporated in the other die member. The torque is recorded autographically as a function of time.

The stiffness of the rubber test piece increases as vulcanization proceeds. The curve is complete when the recorded torque rises either to an equilibrium value or to a maximum value (see ISO 6502-1). If the

torque continues to increase, vulcanization is considered to be complete after a given time. The time required to obtain a vulcanization curve is a function of the test temperature and the characteristics of the rubber compound.

The vulcanization characteristics are obtained from the recorded curve of torque as a function of time, in accordance with ISO 6502-1.

## 5 Apparatus

### 5.1 General

A rotorless curemeter consists of two dies that are heated and closed or almost closed, under a specified force, to form a test cavity that contains a test piece. One of the dies oscillates, and reaction torque on the stationary die, which is opposite to the moving die, can be measured at specified conditions of temperature, frequency and amplitude.

There are two types of assembly surrounding the test cavity formed by the upper and lower dies, one is unsealed or open type, and the other is sealed type. In the case of a sealed type die system, the die cavity is surrounded by seal plates and seal rings, and is completely closed. In the unsealed type the cavity is not completely closed.

Two kinds of cavity shape formed by the dies are used, namely, a biconical shape and a flat plate shape.

Three types of curemeter with different combination of sealing type and die cavity shape are available:

- a) biconical die cavity with unsealed system,
- b) biconical die cavity with sealed system, or
- c) flat plate die cavity (with sealed system). [ISO 6502-3:2018](#)

The general arrangements for rotorless curemeters are shown in [Figure 1](#), [Figure 2](#) and [Figure 3](#), including typical machine dimensions.

Curemeters with different design might result in different torque responses and cure time (see ISO 6502-1:2018, A.2).

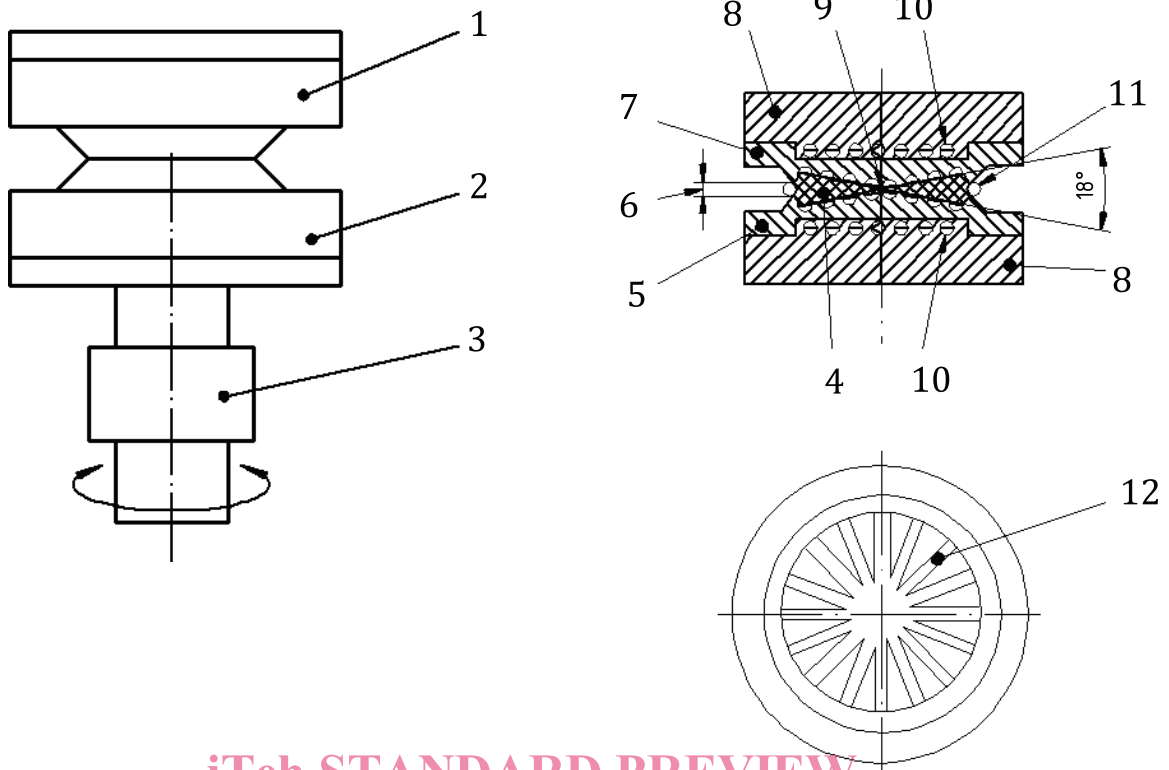

iTeh STANDARD PREVIEW  
(standards.iteh.ai)

Key

- |   |                         |    |                    |
|---|-------------------------|----|--------------------|
| 1 | fixed die               | 7  | upper die          |
| 2 | oscillating die         | 8  | temperature sensor |
| 3 | torque-measuring system | 9  | die gap            |
| 4 | test piece              | 10 | heater             |
| 5 | lower die               | 11 | spew               |
| 6 | die gap                 | 12 | grooves            |

Figure 1 — Typical unsealed torsion-shear rotorless curemeter with biconical-die cavity

Dimensions in millimetres

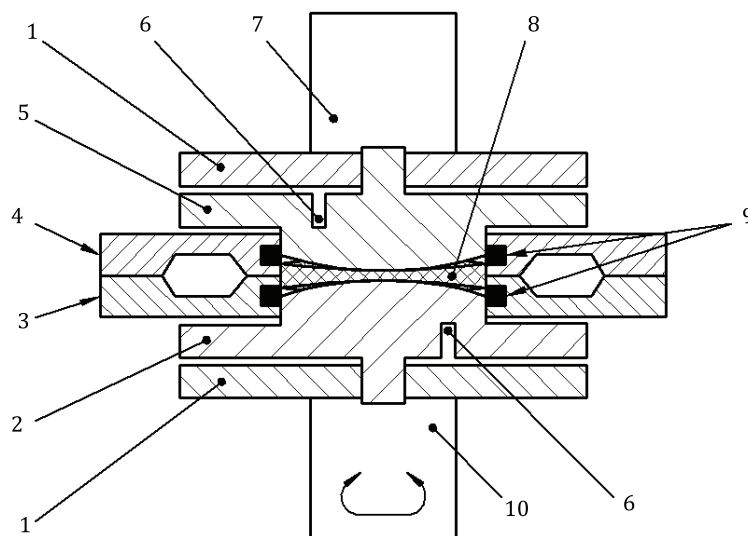

a) Measurement principle

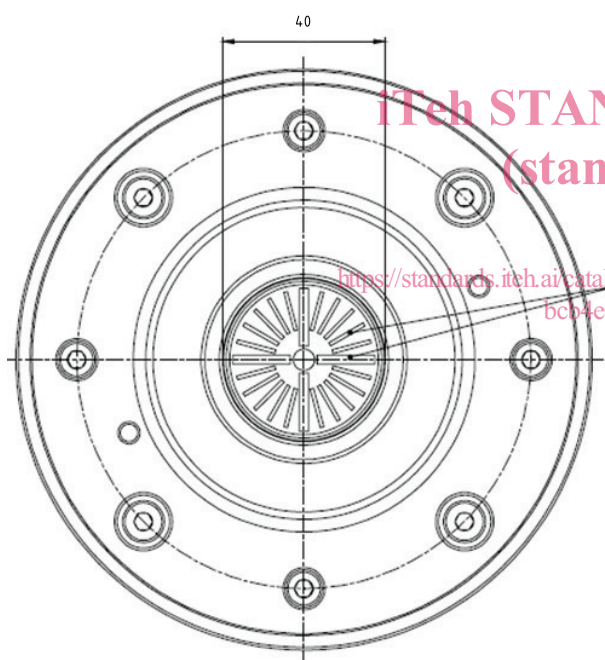

b) Die (upper and lower)

ITeH STANDARD PREVIEW  
(standards.iteh.ai)

ISO 6502-3:2018

<https://standards.iteh.ai/catalog/standards/sist/56d1d11b-a15d-43cb-9824-bcb4eff73769/iso-6502-3-2018>



c) Test piece

**Key**

- |   |                    |    |                          |
|---|--------------------|----|--------------------------|
| 1 | heater             | 7  | torque-measuring system  |
| 2 | lower die          | 8  | test piece               |
| 3 | lower seal plate   | 9  | seals                    |
| 4 | upper seal plate   | 10 | oscillating-drive system |
| 5 | upper die          | 11 | grooves                  |
| 6 | temperature sensor |    |                          |

Figure 2 — Typical sealed torsion-shear rotorless curemeter with biconical-die cavity



Dimensions in millimetres

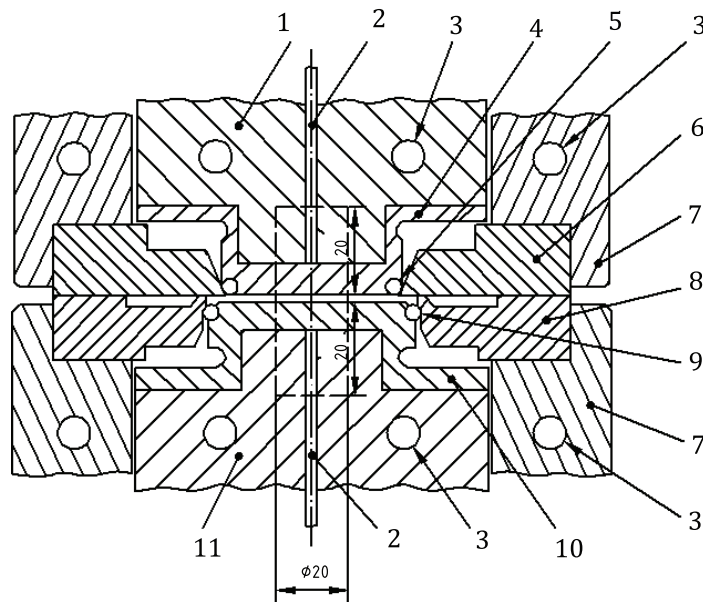

a) Measurement principle

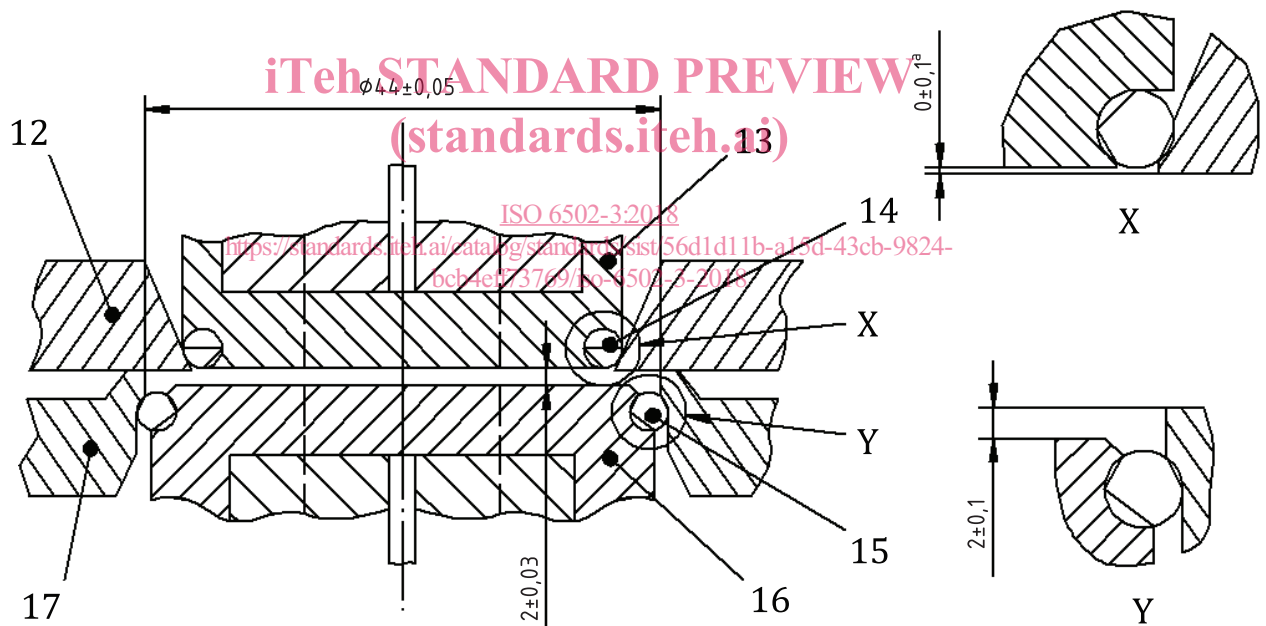

b) Details of dies and seal plates

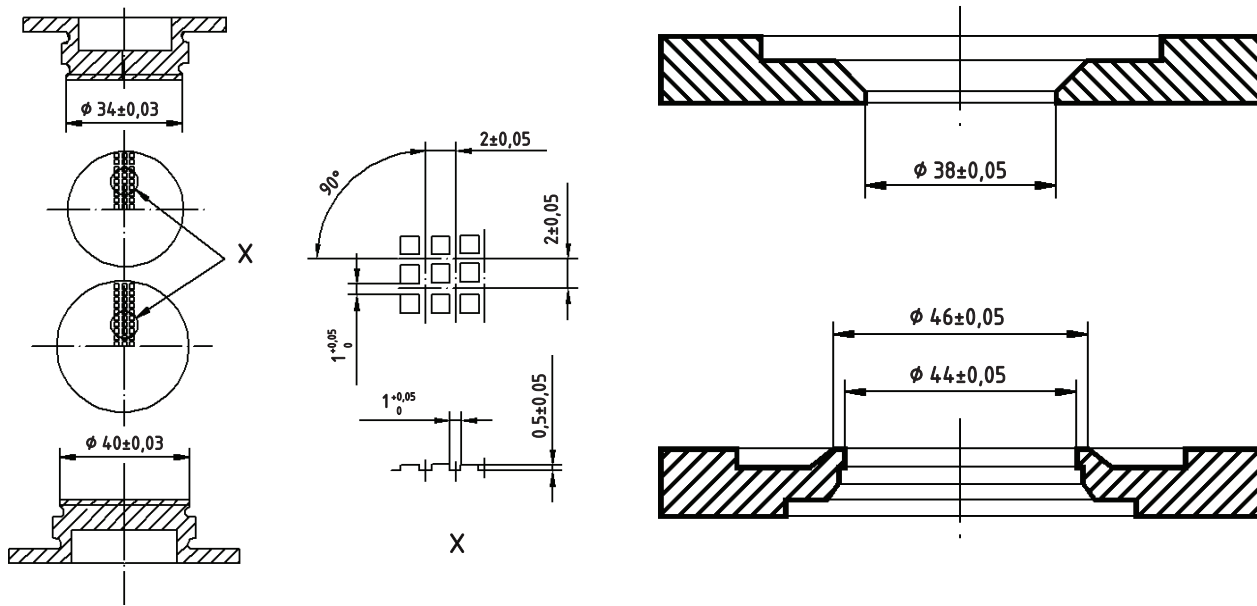

c) Shapes and dimensions of dies and seal plates

Key

- |                                    |                     |
|------------------------------------|---------------------|
| 1 shaft of torque-measuring system | 10 lower die        |
| 2 temperature sensor               | 11 drive shaft      |
| 3 heater                           | 12 upper seal plate |
| 4 upper die                        | 13 upper die        |
| 5 upper seal                       | 14 upper seal       |
| 6 upper seal plate                 | 15 lower seal       |
| 7 platen                           | 16 lower die        |
| 8 lower seal plate                 | 17 lower seal plate |
| 9 lower seal                       |                     |
- a 0±0,1 means that the difference between the bottom level of both parts (right and left) shall be within 0,1 mm.

Figure 3 — Typical sealed torsion-shear rotorless curemeter with flat-plate-die cavity

5.2 Dies

The dies shall be manufactured from a non-deforming, high stiffness and low thermal expansion material to minimize system compliance and prevent gap changes with temperature. The surface of the dies shall be treated to minimize the effect of test piece contamination if protective or carrying film are not used and shall be hard enough to prevent wear. A minimum Rockwell hardness of 50 HRC, or equivalent, is recommended.

A die cavity is formed with a fixed lower die and a vertically-moving upper die, and the shape of the die cavity shall be biconical or flat-plate.

- A biconical die cavity is formed by two conically shaped dies with angle of separation ranging from 7° to 18°. The spacing between both dies facing each other differs by the distance on the periphery than the centre so as to be minimum at the central point, to increase toward the outer side from the central point.
- A flat plate die cavity is disc-shaped. It has same spacing all over the cavity.

Biconical dies are designed to provide a constant shear strain throughout the entire test piece, while flat plate dies give uniform temperature distribution in the test piece.

The top and bottom surfaces of the cavity shall have a pattern of grooves to prevent slippage of the rubber test piece. For the biconical type dies, radial grooves, for the flat plate type dies, checkered pattern grooves are recommended.

Suitable means shall be employed by design of dies or otherwise to apply pressure to the test piece.

The typical dimensions for the die cavity are shown in [Table 1](#). The tolerances necessary on the dimensions of the dies depend on the particular design.

The dimensions of the die cavity can be checked by measuring the dimensions of the vulcanized test piece. For biconical type dies, particular attention should be paid to the thin central portion, the thickness of which depends on the die gap.

**Table 1 — Typical dimensions of die cavity**

	Biconical cavity		Flat-plate cavity
Diameter	40 mm ± 2 mm		44,00 mm ± 0,05 mm
Height	Angle of separation ranging from 7° to 18° In the centre of the dies, a separation equal to 0,5 mm plus the die gap		2,00 mm ± 0,03 mm
Die gap <sup>a</sup>	Unsealed type	Sealed type	Level differences between die and seal plate <sup>b</sup> Upper : 0,0 mm ± 0,1 mm Lower : 2,0 mm ± 0,1 mm
	0,05 mm to 0,20 mm, preferably 0,1 mm	No gap	
Grooves	Radial grooves at 20° intervals	Radial grooves at 18° to 22,5° intervals	In a criss-cross pattern 16 grooves on the upper die 19 grooves on the lower die
<sup>a</sup> The gap between the edges of the dies in the closed position.			
<sup>b</sup> A level difference between the surfaces of the upper die and of the upper seal plate, or lower die and lower seal plate.			

### 5.2.1 Seal plate

For sealed type (biconical cavity or flat plate cavity) die systems, seal plates shall be provided around the upper and lower dies. The seal plates shall be fabricated from sufficiently rigid and abrasion resistant material. A minimum Rockwell hardness of 50 HRC, or equivalent, is recommended.

### 5.2.2 Seal

The sealed type (biconical cavity or flat plate cavity) curemeter shall have suitable low constant friction seals to prevent material leaking from the cavity. The material shall have adequate flexibility, high resistance to the test temperature and to wear. O-rings made from fluororubber, silicone rubber or tetrafluoroethylene resin are recommended.

The seals should be replaced periodically to prevent a lowering of the torque measuring accuracy or leakage of test piece by thermal degradation.

### 5.3 Die closure

The dies shall be held closed during the test by, for example, pneumatic cylinder.

The closing force shall be maintained at 7 kN to 8 kN for dies of a biconical cavity and 7,0 kN ± 0,5 kN for flat plate dies.

For sealed cavities, the contact of the die cavity edges shall be such as to form a perfectly sealed cavity.

**NOTE** For checking the sealing condition, place a piece of soft tissue paper not thicker than 0,04 mm between the mating surfaces and see if continuous pattern of uniform intensity is obtained when the dies are closed. A non-uniform pattern indicates incorrect adjustment of the die closure, worn or faulty mating surfaces, or distortion of the dies. Any of these conditions might result in leakage and erroneous results.