



SLOVENSKI STANDARD
SIST EN 13230-4:2016+A1:2020

01-april-2020

Železniške naprave - Zgornji ustroj proge - Betonski pragi in kretniški betonski pragi - 4. del: Prednapeti betonski pragi za kretnice in križišča

Railway applications - Track - Concrete sleepers and bearers - Part 4: Prestressed bearers for switches and crossings

Bahnanwendungen - Oberbau - Gleis- und Weichenschwellen aus Beton - Teil 4: Spannbetonschwellen für Weichen und Kreuzungen

Applications ferroviaires - Voie - Traverses et supports en béton - Partie 4 : Supports précontraints pour appareil de voie

[SIST EN 13230-4:2016+A1:2020](https://standards.iteh.ai/catalog/standards/sist/7e9bcade-f90e-43fe-b812-e3f1ebd1b33f/sist-en-13230-4:2016+A1:2020)

[https://standards.iteh.ai/catalog/standards/sist/7e9bcade-f90e-43fe-b812-](https://standards.iteh.ai/catalog/standards/sist/7e9bcade-f90e-43fe-b812-e3f1ebd1b33f/sist-en-13230-4:2016+A1:2020)

Ta slovenski standard je istoveten z: EN 13230-4:2016+A1:2020

ICS:

| | | |
|-----------|-----------------------------|--------------------------------|
| 45.080 | Tračnice in železniški deli | Rails and railway components |
| 91.100.30 | Beton in betonski izdelki | Concrete and concrete products |

SIST EN 13230-4:2016+A1:2020 **en,fr,de**

iTeh STANDARD PREVIEW
(standards.iteh.ai)

[SIST EN 13230-4:2016+A1:2020](https://standards.iteh.ai/catalog/standards/sist/7e9bcade-f90e-43fe-b812-e3f4ebdbc33f/sist-en-13230-4-2016a1-2020)

<https://standards.iteh.ai/catalog/standards/sist/7e9bcade-f90e-43fe-b812-e3f4ebdbc33f/sist-en-13230-4-2016a1-2020>

EUROPEAN STANDARD

EN 13230-4:2016+A1

NORME EUROPÉENNE

EUROPÄISCHE NORM

February 2020

ICS 91.100.30; 93.100

English Version

Railway applications - Track - Concrete sleepers and bearers - Part 4: Prestressed bearers for switches and crossings

Applications ferroviaires - Voie - Traverses et supports en béton - Partie 4 : Supports précontraints pour appareil de voie

Bahnanwendungen - Oberbau - Gleis- und Weichenschwellen aus Beton - Teil 4: Spannbetonschwellen für Weichen und Kreuzungen

This European Standard was approved by CEN on 4 March 2016 and includes Amendment 1 approved by CEN on 10 June 2019.

CEN members are bound to comply with the CEN/CENELEC Internal Regulations which stipulate the conditions for giving this European Standard the status of a national standard without any alteration. Up-to-date lists and bibliographical references concerning such national standards may be obtained on application to the CEN-CENELEC Management Centre or to any CEN member.

iTeh STANDARD PREVIEW

This European Standard exists in three official versions (English, French, German). A version in any other language made by translation under the responsibility of a CEN member into its own language and notified to the CEN-CENELEC Management Centre has the same status as the official versions.

CEN members are the national standards bodies of Austria, Belgium, Bulgaria, Croatia, Cyprus, Czech Republic, Denmark, Estonia, Finland, France, Germany, Greece, Hungary, Iceland, Ireland, Italy, Latvia, Lithuania, Luxembourg, Malta, Netherlands, Norway, Poland, Portugal, Republic of North Macedonia, Romania, Serbia, Slovakia, Slovenia, Spain, Sweden, Switzerland, Turkey and United Kingdom.



EUROPEAN COMMITTEE FOR STANDARDIZATION
COMITÉ EUROPÉEN DE NORMALISATION
EUROPÄISCHES KOMITEE FÜR NORMUNG

CEN-CENELEC Management Centre: Rue de la Science 23, B-1040 Brussels

| Contents | Page |
|---|-------------|
| European foreword..... | 4 |
| Introduction | 5 |
| 1 Scope | 6 |
| 2 Normative references | 6 |
| 3 Terms, definitions and symbols | 6 |
| 3.1 Terms and definitions | 6 |
| 3.2 Symbols..... | 7 |
| 4 Special requirement | 7 |
| 4.1 Characteristic bending moments | 7 |
| 4.2 Positioning of fastening components..... | 7 |
| 4.3 Tolerances | 8 |
| 4.3.1 General..... | 8 |
| 4.3.2 Tolerance of planeness | 8 |
| 4.3.3 Tolerances of fastening positioning..... | 8 |
| 4.3.4 Tolerance of vertical deviation from straight..... | 9 |
| 4.4 Distance from the end of the bearer to the nearest cast-in component..... | 9 |
| 5 Product testing | 9 |
| 5.1 General..... | 9 |
| 5.2 Test arrangements..... | 10 |
| 5.3 Test procedures..... | 10 |
| 5.3.1 Test loads | 10 |
| 5.3.2 Static test..... | 11 |
| 5.3.3 Fatigue test | 13 |
| 5.4 Acceptance criteria..... | 14 |
| 5.4.1 General..... | 14 |
| 5.4.2 Static test..... | 14 |
| 5.4.3 Fatigue test | 14 |
| 5.5 Design approval tests | 15 |
| 5.5.1 General..... | 15 |
| 5.5.2 Bending moments evaluation..... | 15 |
| 5.5.3 Concrete..... | 15 |
| 5.5.4 Product inspection..... | 15 |
| 5.6 Routine tests | 15 |
| 5.6.1 General..... | 15 |
| 5.6.2 Positive or negative bending moment evaluations for static test..... | 15 |
| 5.6.3 Concrete..... | 15 |
| 5.6.4 Product checking..... | 16 |
| 6 Manufacturing | 16 |
| 6.1 Manufacturing rules..... | 16 |
| 6.2 Additional marking | 16 |
| 7 Data to be supplied | 16 |
| 7.1 Data supplied by the purchaser | 16 |
| 7.2 Data provided by the supplier..... | 16 |

| | |
|---|-----------|
| Annex A (normative) Detailed drawings of the test arrangements..... | 17 |
| A.1 Articulated support..... | 17 |
| A.2 Resilient pad..... | 18 |
| Annex ZA (informative) Relationship between this European Standard and the Essential Requirements of EU Directive 2016/797/EU aimed to be covered..... | 19 |
| Bibliography | 20 |

iTeh STANDARD PREVIEW (standards.iteh.ai)

[SIST EN 13230-4:2016+A1:2020](https://standards.iteh.ai/catalog/standards/sist/7e9bcade-f90e-43fe-b812-e3f4ebdbc33f/sist-en-13230-4-2016a1-2020)

<https://standards.iteh.ai/catalog/standards/sist/7e9bcade-f90e-43fe-b812-e3f4ebdbc33f/sist-en-13230-4-2016a1-2020>

European foreword

This document (EN 13230-4:2016+A1:2020) has been prepared by Technical Committee CEN/TC 256 “Railway applications”, the secretariat of which is held by DIN.

This document includes Amendment 1 approved by CEN on 6 October 2019.

This document supersedes A1 EN 13230-4:2016 A1.

The start and finish of text introduced or altered by amendment is indicated in the text by tags A1 A1.

This European Standard shall be given the status of a national standard, either by publication of an identical text or by endorsement, at the latest by August 2020, and conflicting national standards shall be withdrawn at the latest by February 2022.

Attention is drawn to the possibility that some of the elements of this document may be the subject of patent rights. CEN shall not be held responsible for identifying any or all such patent rights.

This document has been prepared under a mandate given to CEN by the European Commission and the European Free Trade Association, and supports essential requirements of EU Directive 2016/797/EU.

For relationship with EU Directive 2016/797/EU, see informative Annex ZA, which is an integral part of this document.

This European Standard is one of the EN 13230 series “Railway applications – Track – Concrete sleepers and bearers”, which consist of the following parts:

- Part 1: General requirements; <https://standards.iteh.ai/catalog/standards/sist/7e9bcade-f90e-43fe-b812-e3f4ebdbc33f/sist-en-13230-4-2016a1-2020>
- Part 2: Prestressed monoblock sleepers;
- Part 3: Twin-block reinforced sleepers;
- Part 4: Prestressed bearers for switches and crossings;
- Part 5: Special elements;
- Part 6: Design.

There is a change in the wording of the documents of EN 13230 (series) “design bending moment” is replaced by “characteristic bending moment” and “test bending moment”.

According to the CEN-CENELEC Internal Regulations, the national standards organisations of the following countries are bound to implement this European Standard: Austria, Belgium, Bulgaria, Croatia, Cyprus, Czech Republic, Denmark, Estonia, Finland, France, Germany, Greece, Hungary, Iceland, Ireland, Italy, Latvia, Lithuania, Luxembourg, Malta, Netherlands, Norway, Poland, Portugal, Republic of North Macedonia, Romania, Serbia, Slovakia, Slovenia, Spain, Sweden, Switzerland, Turkey and the United Kingdom.

Introduction

This part of the EN 13230 series defines the specific requirements dedicated to prestressed bearers for switches and crossings.

These are additional requirements to EN 13230-1:2016 that are necessary to have a complete standard dealing with prestressed bearers for switches and crossings.

The document specifies the test arrangements, the test procedures and the corresponding acceptance criteria.

iTeh STANDARD PREVIEW (standards.iteh.ai)

[SIST EN 13230-4:2016+A1:2020](https://standards.iteh.ai/catalog/standards/sist/7e9bcade-f90e-43fe-b812-e3f4ebdbc33f/sist-en-13230-4-2016a1-2020)

<https://standards.iteh.ai/catalog/standards/sist/7e9bcade-f90e-43fe-b812-e3f4ebdbc33f/sist-en-13230-4-2016a1-2020>

1 Scope

This part of the EN 13230 series defines additional technical criteria and control procedures as well as specific tolerance limits related to manufacturing and testing prestressed bearers for switches and crossings with a maximum length of 8,5 m.

Bearers longer than 8,5 m are considered as special elements and are covered by EN 13230-5:2016.

2 Normative references

[A1] The following documents are referred to in the text in such a way that some or all of their content constitutes requirements of this document. For dated references, only the edition cited applies. For undated references, the latest edition of the referenced document (including any amendments) applies. **[A1]**

EN 206, *Concrete - Specification, performance, production and conformity*

EN 13230-1:2016, *Railway applications – Track – Concrete sleepers and bearers – Part 1: General requirements*

FprEN 10138 (all parts), *Prestressing steels*

3 Terms, definitions and symbols

iTech STANDARD PREVIEW
(standards.iteh.ai)

3.1 Terms and definitions

For the purposes of this document, the terms and definitions given in EN 13230-1:2016 and the following apply:

[A1] ISO and IEC maintain terminological databases for use in standardization at the following addresses:

— ISO Online browsing platform: available at <https://www.iso.org/obp>

— IEC Electropedia: available at <http://www.electropedia.org/> **[A1]**

3.1.1

prestressed monoblock bearer

bearer manufactured using pre-tensioned or post-tensioned tendons

3.1.2

characteristic positive bending moment

$M_{k,pos}$

positive bending moment at any position of the bearer

3.1.3

characteristic negative bending moment

$M_{k,neg}$

negative bending moment at any position of the bearer

3.2 Symbols

For the purposes of this document, the symbols listed in Table 1 apply.

Table 1 — Symbols

| Symbol | Definition | Units |
|--------------|---|-------|
| Fb_0 | Positive initial reference test load | kN |
| Fb_{0n} | Negative initial reference test load | kN |
| Fb_r | Test load which produces first crack at the bottom of the bearer | kN |
| Fb_{rn} | Test load which produces first crack at the top of the bearer | kN |
| $Fb_{0,05}$ | Maximum test load for which a crack width of 0,05 mm persists at the bottom of the bearer after removal of the load | kN |
| $Fb_{0,05n}$ | Maximum test load for which a crack width of 0,05 mm persists at the top of the bearer after removal of the load | kN |
| Fb_B | Maximum test load which cannot be increased when the bottom of the bearer is cracked | kN |
| Fb_{Bn} | Maximum test load which cannot be increased when the top of the bearer is cracked | kN |
| Fb_u | Lower test load for the fatigue test: $Fb_u = 0,25 \times Fb_0$ | kN |
| k_b | Impact coefficient for positive static test | |
| k_{bn} | Impact coefficient for negative static test | |
| k_{bB} | Impact coefficient for fatigue test | |
| k_t | Factor used for calculation of acceptance criteria for first crack formation in static tests | |

4 Special requirement

4.1 Characteristic bending moments

The bearer shall be designed with positive and negative characteristic bending moment capacities with the objective of keeping it straight.

4.2 Positioning of fastening components

An area of the concrete section shall be specified by the purchaser to be free from prestressing tendons for the location of fastening components.

If required by the purchaser, the design of the bearer shall provide for the repair or replacement of the embedded fastening components.

4.3 Tolerances

4.3.1 General

The maximum tolerances specified in EN 13230-1:2016, 6.1 apply to concrete bearers.

In case of early dimensional inspection of the concrete element, the quality plan shall take into account further shortening of the element. Measurement of tolerances shall be checked not before 48 h after transfer of prestressing forces.

4.3.2 Tolerance of planeness

The maximum deviation of the total rail seat or base plate area is as follows:

- planeness: 1 mm;
- variation of planeness with regard to 2 points 150 mm apart: 0,5 mm.

4.3.3 Tolerances of fastening positioning

The tolerances of the embedded fastening components positioning shall be measured in accordance with Figure 1.

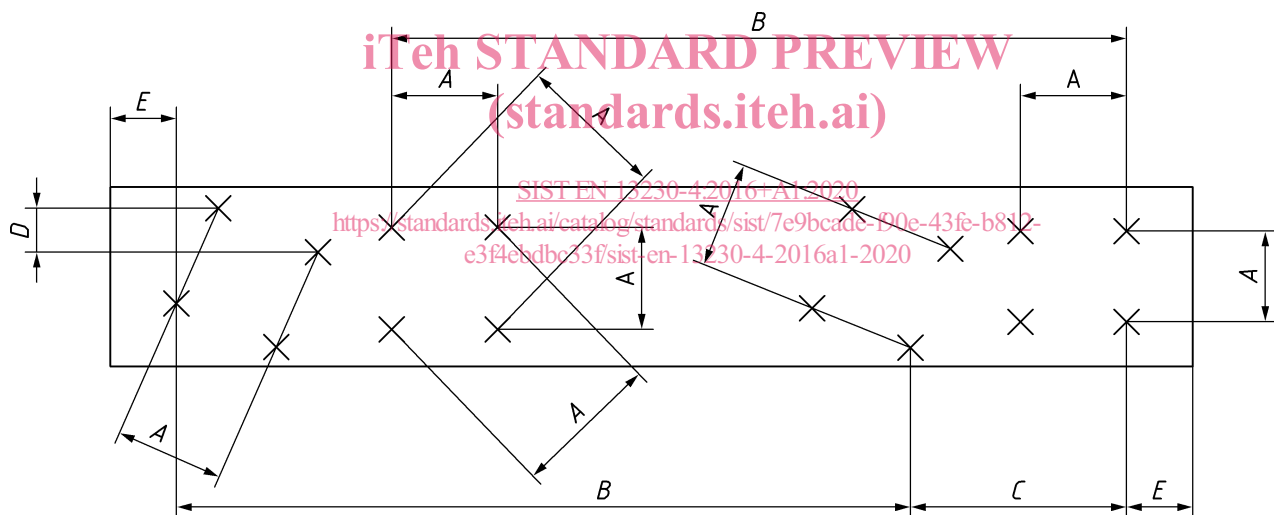

Figure 1 — Measurement of tolerances on fastening components positioning

Tolerance on dimensions A and D (on the same support area): $\pm 1,0$ mm

Tolerance on dimensions B and C (between two separate support areas): $\pm 1,5$ mm

Tolerance between the last cast-in component and the end of the bearer (E): ± 10 mm

The tolerances specified above may be varied by the purchaser in case of special requirements and shall be defined on the drawings submitted by the purchaser.

These tolerances shall apply to all embedded components with either direct or indirect fastening system.

4.3.4 Tolerance of vertical deviation from straight

Figure 2 shows the vertical deviation measurement.

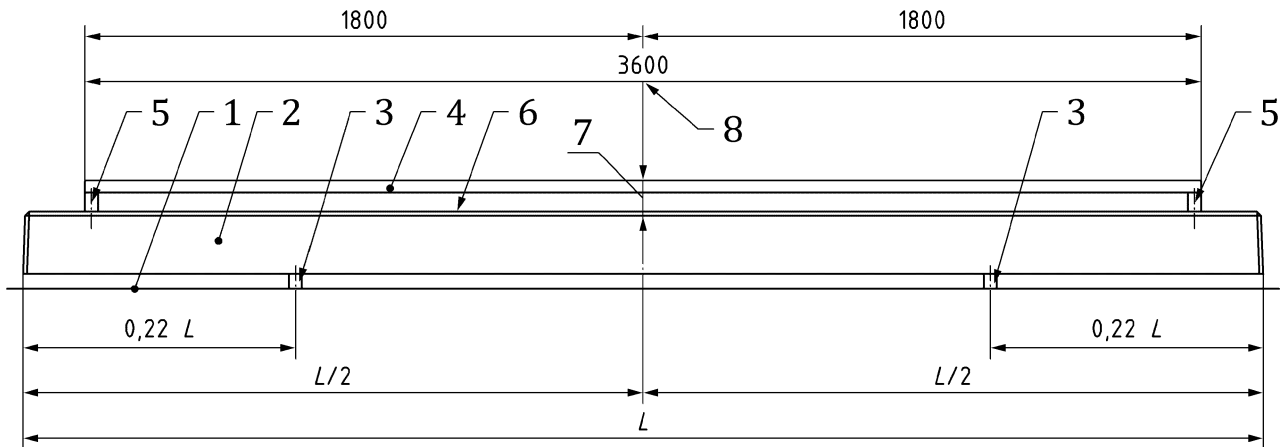

Key

- 1 rigid support
- 2 bearer
- 3 support (50 mm × 50 mm section) across width of bearer
- 4 straight datum
- 5 support across width of bearer
- 6 top surface of bearer
- 7 vertical deviation measurement area
- 8 measurement base

iTech STANDARD PREVIEW
(standards.itech.ai)
SIST EN 13230-4:2016+A1:2020
<https://standards.itech.ai/catalog/standards/sist/7e9bcade-f90e-43fe-b812-e3f4ebdbc33f/sist-en-13230-4-2016a1-2020>

Figure 2 — Vertical deviation measurement

Vertical deviation in both directions is measured on a 3,6 m long base as on Figure 2.

Alternative measurement methods can be proposed by the manufacturer and agreed with the purchaser.

Bearers shorter than 4 m need not be checked.

Maximum allowed deviation is 3 mm on a 3,6 m base.

For bearer length above 6 m, maximum allowed deviation is agreed between supplier and purchaser.

4.4 Distance from the end of the bearer to the nearest cast-in component

The supplier defines the prestress anchoring area and special care to be taken into account for cast-in components near to the end of the bearer.

5 Product testing

5.1 General

This section defines the testing regime and rules for acceptance of concrete bearers.

The layouts of the test arrangements are defined in this section.