**Smoke and heat control systems —
Part 5:
Powered smoke exhaust systems —
Requirements and design**

Installations pour l'extraction de fumée et de chaleur —

*Partie 5: Systèmes d'extraction de fumée mécaniques — Exigences et
planification*

**iTeh STANDARD PREVIEW
(standards.iteh.ai)**

[ISO 21927-5:2018](https://standards.iteh.ai/catalog/standards/sist/10d44a23-a587-4cbd-8fa6-997f39d7d78d/iso-21927-5-2018)

<https://standards.iteh.ai/catalog/standards/sist/10d44a23-a587-4cbd-8fa6-997f39d7d78d/iso-21927-5-2018>



iTeh STANDARD PREVIEW (standards.iteh.ai)

ISO 21927-5:2018

<https://standards.iteh.ai/catalog/standards/sist/10d44a23-a587-4cbd-8fa6-997f39d7d78d/iso-21927-5-2018>



COPYRIGHT PROTECTED DOCUMENT

© ISO 2018

All rights reserved. Unless otherwise specified, or required in the context of its implementation, no part of this publication may be reproduced or utilized otherwise in any form or by any means, electronic or mechanical, including photocopying, or posting on the internet or an intranet, without prior written permission. Permission can be requested from either ISO at the address below or ISO's member body in the country of the requester.

ISO copyright office
CP 401 • Ch. de Blandonnet 8
CH-1214 Vernier, Geneva
Phone: +41 22 749 01 11
Fax: +41 22 749 09 47
Email: copyright@iso.org
Website: www.iso.org

Published in Switzerland

Contents

	Page
Foreword.....	iv
Introduction.....	v
1 Scope.....	1
2 Normative references.....	1
3 Terms and definitions.....	1
4 Design principles.....	2
4.1 General.....	2
4.2 Height of space.....	4
4.3 Target height of the clear layer, d , in a smoke reservoir, A_R	4
4.4 Area of smoke reservoir, A_R	4
4.5 Air supply.....	4
4.5.1 General.....	4
4.5.2 Natural air replacement.....	5
4.5.3 Powered air replacement.....	5
4.6 Duration of fire growth to be assumed in the design.....	5
4.7 Design group.....	5
5 Calculating the volume flow of the smoke gases to be exhausted.....	6
5.1 Basis of the calculation.....	6
5.2 Using the tables.....	6
6 Component temperature classes.....	8
7 Rules for installation.....	9
8 Energy supply for powered smoke exhaust ventilators.....	13
9 Controlling powered smoke exhaust ventilators.....	13
10 Marking.....	13
Bibliography.....	14

Foreword

ISO (the International Organization for Standardization) is a worldwide federation of national standards bodies (ISO member bodies). The work of preparing International Standards is normally carried out through ISO technical committees. Each member body interested in a subject for which a technical committee has been established has the right to be represented on that committee. International organizations, governmental and non-governmental, in liaison with ISO, also take part in the work. ISO collaborates closely with the International Electrotechnical Commission (IEC) on all matters of electrotechnical standardization.

The procedures used to develop this document and those intended for its further maintenance are described in the ISO/IEC Directives, Part 1. In particular, the different approval criteria needed for the different types of ISO documents should be noted. This document was drafted in accordance with the editorial rules of the ISO/IEC Directives, Part 2 (see www.iso.org/directives).

Attention is drawn to the possibility that some of the elements of this document may be the subject of patent rights. ISO shall not be held responsible for identifying any or all such patent rights. Details of any patent rights identified during the development of the document will be in the Introduction and/or on the ISO list of patent declarations received (see www.iso.org/patents).

Any trade name used in this document is information given for the convenience of users and does not constitute an endorsement.

For an explanation of the voluntary nature of standards, the meaning of ISO specific terms and expressions related to conformity assessment, as well as information about ISO's adherence to the World Trade Organization (WTO) principles in the Technical Barriers to Trade (TBT) see www.iso.org/iso/foreword.html.

This document was prepared by Technical Committee ISO/TC 21, *Equipment for fire protection and fire fighting*, Subcommittee SC 11, *Smoke and heat control systems and components*.

A list of all parts in the ISO 21927 series can be found on the ISO website.

Any feedback or questions on this document should be directed to the user's national standards body. A complete listing of these bodies can be found at www.iso.org/members.html.

Introduction

Smoke and heat control systems (SHCS) create and maintain smoke free areas in construction works by controlling smoke flow, and thus improving the conditions for the safe escape and/or rescue of people and animals and the protection of property, and permit the fire to be fought while still in its early stages. The use of smoke and heat exhaust ventilation systems (SHEVS) to create smoke-free areas beneath a buoyant smoke layer has become widespread. Their value in assisting in the evacuation of people from construction works, reducing fire damage and financial loss by preventing smoke logging, facilitating firefighting, reducing roof temperatures and retarding the lateral spread of fire is firmly established. For these benefits to be obtained, it is essential that smoke and heat exhaust ventilators operate fully and reliably whenever called upon to do so during their installed life. A heat and smoke exhaust ventilation system is a scheme of safety equipment intended to play a positive role in a fire emergency.

Components for any smoke and heat control system are installed as part of a properly designed system.

Smoke and heat control systems help to:

- keep escape and access routes free from smoke;
- facilitate firefighting operations;
- delay and/or prevent flashover and thus full development of a fire;
- protect equipment and furnishings;
- reduce thermal effects on structural components during a fire;
- reduce damage due to thermal decomposition products and hot gases.

Pressure differential systems are used either to positively pressurize spaces separated from the fire or to depressurize the space containing the fire in order to limit or prevent the flow of smoke and heat into adjacent spaces. A typical use would be to pressurize an escape stair well in order to protect vertical means of escape.

Depending on the design of the system, natural or powered smoke and heat ventilators can be used in a smoke and heat control system.

Control equipment is needed to control all components in a SHCS, such as:

- natural ventilators;
- powered ventilators;
- smoke barriers;
- smoke dampers;
- air inlets;
- duct sections;
- dampers.

SHCS control equipment can also provide control for day-to-day ventilation and signals to other fire safety equipment under fire conditions.

SHCS control equipment can be for extra-low-voltage or low-voltage electrical systems or pneumatic systems or any combination thereof.

iTeh STANDARD PREVIEW
(standards.iteh.ai)

ISO 21927-5:2018

<https://standards.iteh.ai/catalog/standards/sist/10d44a23-a587-4cbd-8fa6-997f39d7d78d/iso-21927-5-2018>

Smoke and heat control systems —

Part 5:

Powered smoke exhaust systems — Requirements and design

1 Scope

This document applies to powered smoke exhaust systems in spaces with a large area and with a ceiling height of minimum 3 m, in which smoke protection is required. It includes tables and calculation methods for the design of clear layers in order to comply, inter alia, with the requirements of various protection objectives.

This document includes information and provisions concerning the requirements for powered smoke exhaust systems, their design and rules for their installation.

NOTE The requirements for testing the ventilators are dealt with in ISO 21927-3. Other parts of the ISO 21927 series of standards deal with the power supply (ISO 21927-10), control equipment (ISO 21927-9) and smoke control ducts and smoke control dampers (ISO 21927-7 and ISO 21927-8 respectively).

Design, as specified in this document, does not apply to:

- spaces with fixed gas extinguishing systems;
- storage facilities for hazardous materials;
- spaces in which there is a risk of explosions;
- corridors;
- stairwells.

2 Normative references

The following documents are referred to in the text in such a way that some or all of their content constitutes requirements of this document. For dated references, only the edition cited applies. For undated references, the latest edition of the referenced document (including any amendments) applies.

ISO 21927-3, *Smoke and heat control systems — Part 3: Specification for powered smoke and heat exhaust ventilators*

ISO 21927-8, *Smoke and heat control systems — Part 8: Smoke control dampers*

ISO 21927-9, *Smoke and heat control systems — Part 9: Specification for control equipment*

3 Terms and definitions

For the purposes of this document, the terms and definitions given in ISO 21927-3 and the following apply.

ISO and IEC maintain terminological databases for use in standardization at the following addresses:

- IEC Electropedia: available at <https://www.electropedia.org/>
- ISO Online browsing platform: available at <https://www.iso.org/obp>

**3.1
roof-mounted ventilator**

smoke exhaust ventilator designed to be mounted on a roof above a smoke reservoir and having exterior weather protection

**3.2
wall-mounted ventilator**

smoke exhaust ventilator designed to be mounted in the upper part of an external wall

**3.3
centrally installed ventilator**

smoke exhaust ventilator to which *smoke control ducts* (3.7) from several smoke reservoirs can be connected

**3.5
area of smoke reservoir**

A_a
area within a large space enclosed or bounded by smoke barriers or wall elements

**3.6
design group**

auxiliary design value that is used in the design of powered smoke exhaust systems and takes account of the assumed duration of fire growth and the fire propagation rate

**3.7
smoke control duct**

duct through which smoke and heat are exhausted

**3.8
single compartment smoke control damper**

smoke control damper that is designed for use in a single smoke reservoir and can be connected to single compartment *smoke control ducts* (3.7)

**3.9
multi-compartment smoke control damper**

fire-resistant smoke control damper designed for use in or on *smoke control ducts* (3.7) connecting several smoke reservoirs, or in separating structural elements

4 Design principles

4.1 General

The design of powered smoke exhaust systems (see example in [Figure 1](#)) depends, inter alia, on the heat release rate, the theoretical fire area of a building or the resulting design group, the target height of the clear layer and the height of the space. Possible locations and designs of smoke exhaust ventilators are described in ISO 21927-3.

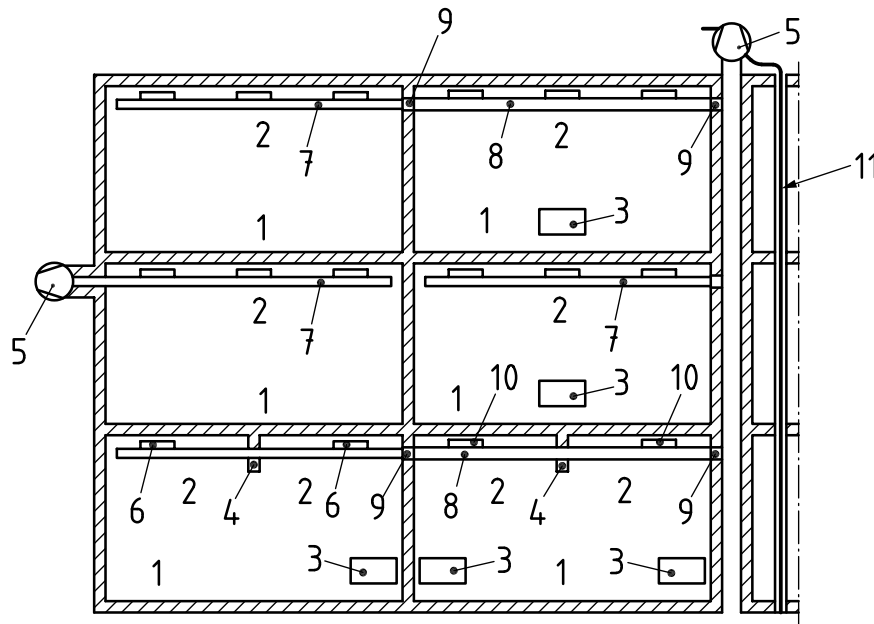

Key

- 1 possible fire compartment
- 2 smoke layer in smoke reservoir
- 3 air inlet
- 4 smoke barrier (ISO 21927-1)
- 5 smoke exhaust ventilator (ISO 21927-3)
- 6 single compartment smoke control damper (ISO 21927-8)
- 7 smoke control duct for which there are no requirements for the duration of fire resistance (ISO 21927-7)
- 8 smoke control duct for which requirements for the duration of fire resistance apply (ISO 21927-7)
- 9 multi-compartment smoke control damper, installed in a wall or floor (ISO 21927-8)
- 10 multi-compartment smoke control damper, installed in a smoke control duct (ISO 21927-8)
- 11 electric cables

Figure 1 — Diagram showing possible powered smoke exhaust systems

The values to be used to determine the above parameters are auxiliary design values and they only apply to designs in accordance with this document.

Design is based on the following:

- the powered smoke exhaust system is activated at an early stage, e.g. by an automatic fire alarm system with smoke detectors, or immediately by trained personnel that are in attendance around the clock;
- the mean fire propagation rate for an assumed duration of fire growth is around 10 min;
- there is a sufficiently large and evenly distributed air supply through inlets close to floor level; the air supply needs to be effective from the time the powered smoke exhaust system is switched on to avoid turbulence in the smoke (flow rate not greater than 1 m/s at the point at which the replacement air enters the smoke reservoir; this can be achieved by using deflectors, for example);
- large spaces are divided into smoke reservoirs by means of smoke barriers;
- the fires are solid materials fires;
- the fire area does not exceed 80 m² up to the time at which extinguishing measures commence;

- the smoke layer temperatures are below flash-over level.

4.2 Height of space

The height, h , of the space to be protected (as shown in [Figure 2](#)), shall be the distance from the floor to the lower surface of the roof/floor in the case of horizontal roofs/floors. For pitched roofs or sloping floors, it shall be the mean distance from the floor to the lower surface of the roof/floor. Floors with smoke outlets are not regarded as floors in this context.

In the case of sawtooth roofs, the space height to be used for design purposes is the mean height of the extraction point of the powered smoke exhaust system above floor level.

4.3 Target height of the clear layer, d , in a smoke reservoir, A_R

The clear layer, d , is defined as the distance between the surface of the floor assumed for design purposes and the lower surface of the smoke layer.

Clear layers enable:

- the occupants of a building to escape to safety,
- the emergency services to rescue people, animals and property,
- fires to be fought effectively, and
- damage due to fire gases and products of thermal decomposition to be reduced.

The target height of the clear layer d (see [Figure 2](#)) should be not less than 2,50 m.

Design should be based on higher values of d if so required by the purpose for which the space is to be used (e.g. spaces containing objects sensitive to smoke or flammable warehouse stock). The distance between the objects to be protected and the smoke layer should not be less than 0,5 m.

For clear layers with a height $d \leq 4$ m, the height of the smoke barrier shall protrude at least 0,5 m into the clear layer. For clear layers with a height $d > 4$ m the smoke barrier shall at least equal to the height of the smoke layer, z , but not less than 1,0 m in all cases.

4.4 Area of smoke reservoir, A_R

To enable powered smoke exhaust systems to be designed according to this document, spaces shall either have a maximum area of 1 600 m² or be divided into smoke reservoirs with a maximum area, A_R , of 1 600 m² by means of smoke barriers. The maximum distance between smoke barriers or between wall and smoke barrier shall not exceed 60 m. Any further subdivisions (e.g. closed joists) within the smoke reservoir will not affect the design.

NOTE Smoke reservoirs are created by placing separating elements around the perimeter of a space or, at the minimum, by placing continuous smoke barriers along the open inner sides of a space. A "space" is defined as an area enclosed by separating elements on all sides.

4.5 Air supply

4.5.1 General

A sufficient replacement air supply close to floor level shall be available immediately (e.g. initiated automatically, by the works fire service or as a result of operational or organizational measures) after activation of the powered smoke exhaust system.

The distance between the upper edge of the replacement air inflow and the bottom of the layer of smoke gases shall be not less than 1 m. The distance may be reduced to 0,5 m in the vicinity of replacement air inlets with widths not greater than 1,25 m.

In the case of replacement air inflows resulting in an upward air flow (e.g. those with protective gratings facing upwards), the distance between the upper edge of the replacement air inlet and the bottom of the layer of smoke gases should be not less than 1,5 m.

The air supply can be replenished via openings in the external walls, with the replacement air either being allowed to flow freely into the building, or being conveyed by fans. Powered smoke exhaust systems may operate with a combination of powered and a natural air replacement.

The air replacement rate should not exceed 1 m/s at the point at which the air enters the smoke reservoir.

The air velocity in the replacement air inlet may be greater if appropriate measures (e.g. baffles, deflectors, redirection of air flow at the air inlets) ensure that the horizontal air replacement rate is reduced to 1 m/s at the point at which air enters the smoke reservoir.

4.5.2 Natural air replacement

The following are considered as air inlets:

- separate supply air devices;
- doors or windows provided they are labelled as “air inlets for powered smoke exhaust systems” on the inside and outside and can be opened from outside without being destroyed in the process (e.g. window panes shall not need to be smashed or walls or doors broken down).

4.5.3 Powered air replacement

For the purposes of this document, the volume flow of the replacement air shall be assumed to be equivalent to that of the smoke gases to be exhausted in the case of powered air replacement.

The powered air replacement should be activated either shortly before or at the same time as the powered smoke exhaust system in order to prevent negative pressures occurring in the fire compartment. An automatic control system is therefore preferable.

4.6 Duration of fire growth to be assumed in the design

The duration of fire growth to be assumed for the purposes of this document includes the time that elapses between the outbreak of a fire and the start of firefighting measures. The time elapsing between the outbreak of a fire and the fire alarm being raised is not taken into account as it can either be assumed that the powered smoke exhaust system will be activated at an early stage by a fire detection system or it is ensured that the fire services will be notified promptly and the powered smoke exhaust system is switched on by trained staff that are in attendance around the clock.

An average time of 10 min shall be assumed for the duration of fire growth. In favourable circumstances, such as where there are on-site firefighters, this time may be reduced to 5 min. It shall be increased to 15 min if the circumstances are unfavourable and to 20 min if the circumstances are exceptionally unfavourable.

Powered smoke exhaust systems will need to be combined with an automatic extinguishing system if the assumed duration of fire growth is greater than 20 min and the fire propagation rate exceeds even average values.

4.7 Design group

The design group according to [Table 1](#) corresponds to a theoretical fire area. It is obtained from the assumed duration of fire growth and the fire propagation rate.

The fire propagation rates given in [Table 2](#) are mean values that may be used without further verification. Generally speaking, the values given in line 2 of [Table 1](#) shall be taken as the assumed duration of fire growth. The relevant line and column are highlighted in bold type in [Table 1](#).