

DRAFT INTERNATIONAL STANDARD

ISO/DIS 13997

ISO/TC 94/SC 13

Secretariat: SNV

Voting begins on:
2022-06-09

Voting terminates on:
2022-09-01

Protective clothing — Mechanical properties — Determination of resistance to cutting by sharp objects

Vêtements de protection — Propriétés mécaniques — Détermination de la résistance à la coupure par des objets tranchants

ICS: 13.340.10

iTeh STANDARD PREVIEW
(standards.iteh.ai)

[ISO/FDIS 13997](#)

<https://standards.iteh.ai/catalog/standards/sist/7e8ea6c2-92a4-405b-b60e-ac9acaa0fcdf/iso-fdis-13997>

This document is circulated as received from the committee secretariat.

THIS DOCUMENT IS A DRAFT CIRCULATED FOR COMMENT AND APPROVAL. IT IS THEREFORE SUBJECT TO CHANGE AND MAY NOT BE REFERRED TO AS AN INTERNATIONAL STANDARD UNTIL PUBLISHED AS SUCH.

IN ADDITION TO THEIR EVALUATION AS BEING ACCEPTABLE FOR INDUSTRIAL, TECHNOLOGICAL, COMMERCIAL AND USER PURPOSES, DRAFT INTERNATIONAL STANDARDS MAY ON OCCASION HAVE TO BE CONSIDERED IN THE LIGHT OF THEIR POTENTIAL TO BECOME STANDARDS TO WHICH REFERENCE MAY BE MADE IN NATIONAL REGULATIONS.

RECIPIENTS OF THIS DRAFT ARE INVITED TO SUBMIT, WITH THEIR COMMENTS, NOTIFICATION OF ANY RELEVANT PATENT RIGHTS OF WHICH THEY ARE AWARE AND TO PROVIDE SUPPORTING DOCUMENTATION.

ISO/CEN PARALLEL PROCESSING



Reference number
ISO/DIS 13997:2022(E)

© ISO 2022

iTeh STANDARD PREVIEW
(standards.iteh.ai)

ISO/FDIS 13997

<https://standards.iteh.ai/catalog/standards/sist/7e8ea6c2-92a4-405b-b60e-ae9acaa0fcdf/iso-fdis-13997>



COPYRIGHT PROTECTED DOCUMENT

© ISO 2022

All rights reserved. Unless otherwise specified, or required in the context of its implementation, no part of this publication may be reproduced or utilized otherwise in any form or by any means, electronic or mechanical, including photocopying, or posting on the internet or an intranet, without prior written permission. Permission can be requested from either ISO at the address below or ISO's member body in the country of the requester.

ISO copyright office
CP 401 • Ch. de Blandonnet 8
CH-1214 Vernier, Geneva
Phone: +41 22 749 01 11
Email: copyright@iso.org
Website: www.iso.org

Published in Switzerland

Contents

	Page
Foreword.....	iv
Introduction.....	v
1 Scope.....	1
2 Normative reference.....	1
3 Terms and definitions.....	1
4 Sampling.....	2
4.1 General.....	2
4.2 Textiles and other materials.....	2
4.3 Gloves.....	3
4.4 Conditioning.....	4
5 Test method.....	4
5.1 Principle.....	4
5.2 Test apparatus.....	5
5.2.1 Rigid framework.....	6
5.2.2 Force application system.....	7
5.2.3 Mandrel.....	7
5.2.4 Specimen holder.....	7
5.2.5 Specimen securing clamp.....	7
5.2.6 Blades.....	8
5.2.7 Blade holder.....	9
5.2.8 Cutting-motion system.....	9
5.2.9 Cut-stroke length measurement system.....	9
5.3 Calibration.....	9
5.3.1 Beam Balancing Procedure.....	9
5.3.2 Cutting speed adjustment.....	10
5.3.3 Validation of blades.....	10
5.4 Test procedure.....	11
5.4.1 Specimen mounting.....	11
5.4.2 Test procedure for measuring the cut through distance.....	12
5.4.3 Test procedure for determining the calculated cutting force.....	12
6 Test report.....	13
Annex A (informative) Inter-laboratory test data analysis.....	14
Annex B (normative) Calculated cutting load determination.....	15
Annex C (normative) Testing of the calibration material (see clause 5.3.3.1).....	20
Bibliography.....	21

Foreword

ISO (the International Organization for Standardization) is a worldwide federation of national standards bodies (ISO member bodies). The work of preparing International Standards is normally carried out through ISO technical committees. Each member body interested in a subject for which a technical committee has been established has the right to be represented on that committee. International organizations, governmental and non-governmental, in liaison with ISO, also take part in the work. ISO collaborates closely with the International Electrotechnical Commission (IEC) on all matters of electrotechnical standardization.

The procedures used to develop this document and those intended for its further maintenance are described in the ISO/IEC Directives, Part 1. In particular the different approval criteria needed for the different types of ISO documents should be noted. This document was drafted in accordance with the editorial rules of the ISO/IEC Directives, Part 2 (see www.iso.org/directives).

Attention is drawn to the possibility that some of the elements of this document may be the subject of patent rights. ISO shall not be held responsible for identifying any or all such patent rights. Details of any patent rights identified during the development of the document will be in the Introduction and/or on the ISO list of patent declarations received (see www.iso.org/patents).

Any trade name used in this document is information given for the convenience of users and does not constitute an endorsement.

For an explanation on the meaning of ISO specific terms and expressions related to conformity assessment, as well as information about ISO's adherence to the World Trade Organization (WTO) principles in the Technical Barriers to Trade (TBT) see the following URL: www.iso.org/iso/foreword.html.

The committee responsible for this document is ISO/TC 94, *Personal safety — Protective clothing and equipment*, Subcommittee SC 13, *Protective clothing* and Technical Committee CEN/TC 162, *Protective clothing including hand and arm protection and lifejackets* in collaboration.

This second edition cancels and replaces the first edition (ISO 13997:1999), which has been technically revised.

This document has been completely rewritten based on the current practices and experience in cut testing as well as comparing other cut test methods standards around the world. Following is a list of changes from the previous edition of ISO 13997:

- new blades;
- new neoprene, with calibration data and [Annex C](#);
- new sample carrier;
- new [Figure 3](#);
- new data form ILT [Annex A](#);
- new [Annex B](#) for calculation.

Introduction

Although textiles, composites, leather, rubbers and reinforced materials may resist cutting by sharp edges in different ways, a test method for evaluating the resistance to cut of materials in protective clothing needs to be applicable to all materials. The test described in this International Standard provides a method that allows calculations of the downwards (normal) force required to cause a blade drawn across the sample for a fixed distance to cut through the specimen.

The performance of protective clothing materials may be classified using the numerical values obtained from this test.

iTeh STANDARD PREVIEW
(standards.iteh.ai)

ISO/FDIS 13997

<https://standards.iteh.ai/catalog/standards/sist/7e8ea6c2-92a4-405b-b60e-ae9acaa0fcdf/iso-fdis-13997>

Protective clothing — Mechanical properties — Determination of resistance to cutting by sharp objects

1 Scope

This International Standard specifies a tomodynamometer cut test method and related calculations, for use on materials and assemblies designed for protective clothing, including gloves. The test determines resistance to cutting by sharp edges, such as knives, sheet metal parts, swarf, glass, bladed tools and castings.

When this document is cited as a test method in a material or product requirement standard, that standard shall contain the necessary information to permit the application of ISO 13997 to the particular product.

This test does not provide data on the resistance to penetration by pointed objects such as needles and thorns, or the point of sharp-edged blades. The test described in this International Standard is not considered suitable for testing materials made from chain mail and metal plates. The text of this International Standard does not include provisions for the safeguard of the operator.

2 Normative reference

The following documents are referred to in the text in such a way that some or all of their content constitutes requirements of this document. For dated references, only the edition cited applies. For undated references, the latest edition of the referenced document (including any amendments) applies.

ISO 37, *Rubber, vulcanized or thermoplastic — Determination of tensile stress-strain properties*

ISO 34-1, *Rubber, vulcanized or thermoplastic - Determination of tear strength - Part 1: Trouser, angle and crescent test pieces*

ISO 23529, *Rubber — General procedures for preparing and conditioning test pieces for physical test methods*

ISO 48-2, *Rubber, vulcanized or thermoplastic — Determination of hardness — Part 2: Hardness between 10 IRHD and 100 IRHD*

ISO 2781, *Rubber, vulcanized or thermoplastic — Determination of density*

3 Terms and definitions

For the purposes of this document, the terms and definitions given in ISO 11610 and the following apply.

ISO and IEC maintain terminological databases for use in standardization at the following addresses:

- ISO Online browsing platform: available at <https://www.iso.org/obp>
- IEC Electropedia: available at <https://www.electropedia.org>

3.1

cut-through

event which has occurred when the blade edge first contacts the conducting material below the test specimen

3.2

cutting force

calculated force that would be required to be applied to a blade of standard sharpness to cut through a material in a blade stroke of length 20 mm

3.3

cutting stroke length

distance the cutting-edge travels before cut-through occurs

4 Sampling

4.1 General

Unless otherwise specified, specimen dimensions shall not be less than 25 mm by 100 mm as this allows up to 9 cuts on the same sample (see 5.2.4 and Figure 6). If this sample size is not possible, the smallest specimen on which single cuts are made shall not be less than 25 mm by 25 mm.

NOTE the test requires more than 15 cuts therefore at least 2 specimens are necessary.

4.2 Textiles and other materials

Specimens shall be taken from regions of the sample product representative of the range of construction present in protective areas or as defined in product requirement standard. In the case of an irregular design, the test specimen shall be taken from the area where the least protection is expected.

Specimens from textile materials shall be prepared so that test cuts are made at an angle of $(45 \pm 5)^\circ$ to the warp and weft direction as defined in Figure 1. Only one result (cutting force see clause 5.4.4.2) shall be reported.

Materials that have no clear orientation shall be tested in two directions at 45° to each other. 2 cutting forces (see clause 5.4.4.2) shall be reported and the final result is the lowest one.

If the material is known to have homogenous properties in all directions, only one result (cutting force see clause 5.4.4.2) shall be reported.

NOTE Materials that have no clear orientation are for example, unoriented materials, or those in which the machine direction either does not exist or is uncertain such as some non-wovens.

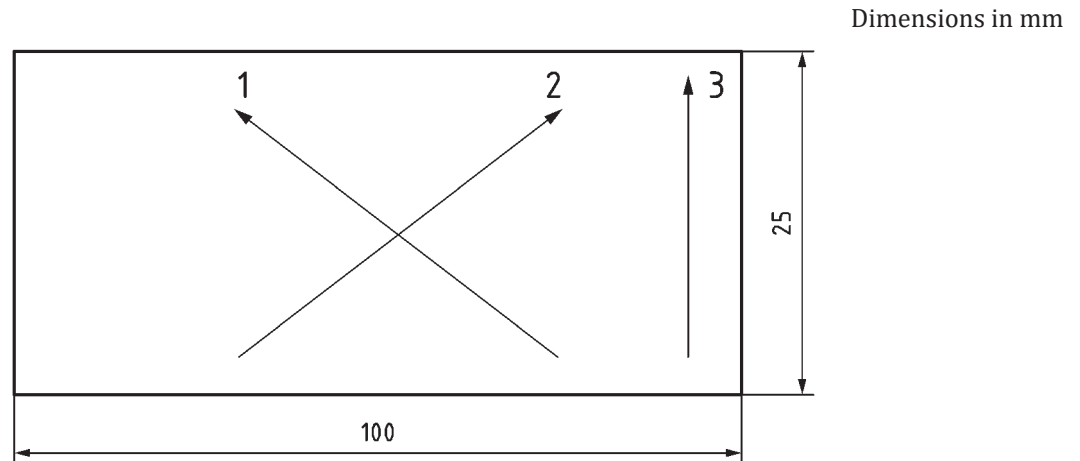
**Key**

- 1 warp or longitudinal direction
- 2 weft or transversal direction
- 3 cut test direction

Figure 1 — Control specimen dimensions and cut direction for garments

4.3 Gloves iTeh STANDARD PREVIEW

For gloves, take the specimen from the palm area cut on the bias such that the size of the specimen is adequate but at an angle as close as possible to 45° as shown in [Figure 2](#).

In the case of an irregular design of the palm, the test specimen shall be taken from the palm area where the least protection is expected.

NOTE 1 If reinforcement(s) does not uniformly cover the palm area, either the specimen shall be taken without reinforcement or the specimen shall be provided without reinforcement.

If cut protection is claimed for back of the hand or cuff and the materials are different from the palm, they shall be tested and reported

NOTE 2 There is no tolerance to the angle for the glove as this depends on the size of the glove and its construction to take the correct angle that best represents a 45° angle.

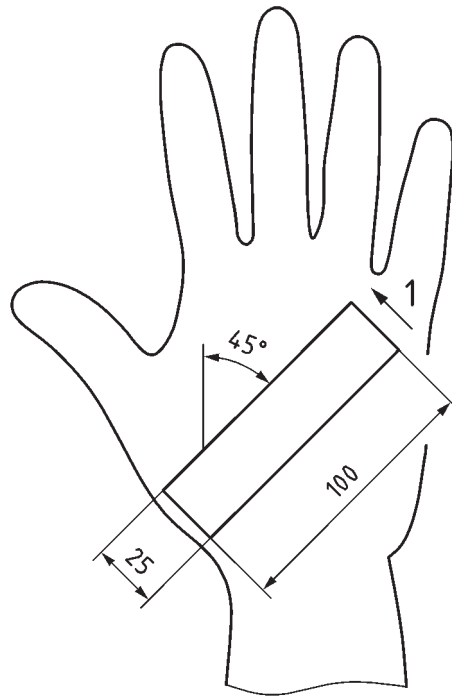

Key
1 cut test direction

iTeh STANDARD PREVIEW
(standards.iteh.ai)

Figure 2 — Glove samples and cut direction

ISO/FDIS 13997

4.4 Conditioning

Specimens shall be conditioned as defined in product requirement standard or in the following conditioning atmosphere:

- Temperature (23 ± 2) °C and relative Humidity (50 ± 5) %.

Alternatively, the following conditioning should be used, and shall be reported in the test report.

- Temperature (20 ± 2) °C and relative Humidity (65 ± 5) %.

The period of conditioning is at least 24 h. Testing shall be carried out in the conditioning environment or within 30 min of withdrawing the specimens from the conditioning environment.

5 Test method

5.1 Principle

The cut resistance of a material is its ability to resist being cut through by a blade. This is measured in a machine in which a sharp blade is drawn across a specimen. The cuts are achieved in blade movements of 5,0 mm to 50,0 mm length when a range of forces are applied to the blade normal to the specimen surface. The cut resistance of a sample material is expressed as the cutting force that is required to be applied to a blade of standard sharpness to just cut through the material in a 20,0 mm blade stroke. The value of the cutting force may be used to classify materials.

The cut test apparatus consists of the following primary components (see [Figure 3](#)): blade holder (1) with a straight line mechanism that holds a blade (2) a specimen (5) with a conductive strip (6) and

double side mounting tape (7) mounted to a specimen holder (8) attached to the mandrel (9) to which the force is applied.

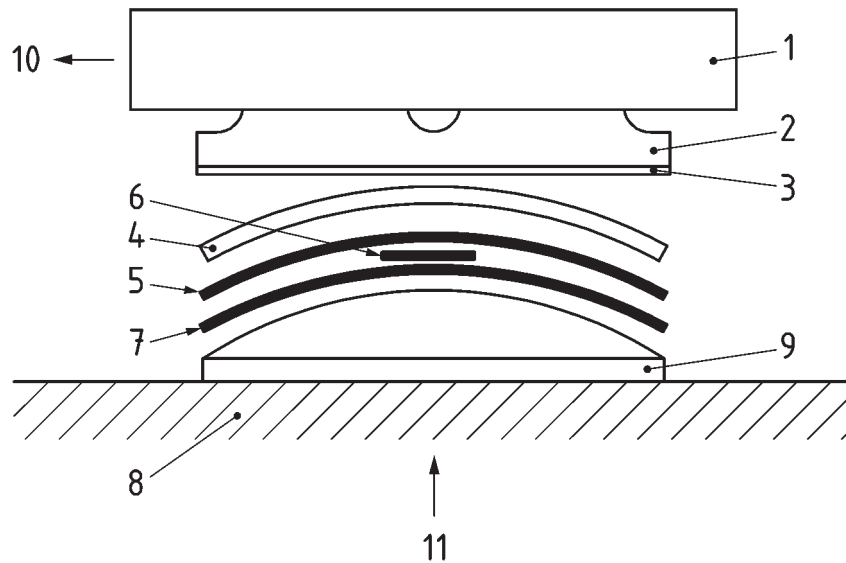

Key

1	blade holder	7	mounting tape
2	blade	8	specimen holder
3	cutting edge of blade	9	mandrel
4	securing clamp	10	cut direction
5	specimen	11	applied force
6	conductive strip		

ISO/EDIS 13997

<https://standards.iteh.ai/catalog/standards/sist/7e8ea6c2-92a4-405b-b60e-ae9acaa0fcd/iso->

Figure 3 — Schematic of the cut test principle

Any apparatus can be used that can maintain a constant force between the cutting edge and the specimen and can accurately measure the distance the blade travels to cut through the specimen. The testing apparatus shall also allow the test to be performed in the conditions specified in the test method, for instance in terms of displacement rate of the blade and geometry of the sample holder (see [section 5.2](#)).

Test apparatus may have limitations in testing materials with a thickness greater than 12 mm (see [5.2.7](#)).

NOTE For each of the required measurements performed in accordance with this standard, a corresponding estimate of the uncertainty of measurement should be evaluated. One of the following approaches shall be used:

- a statistical method, e.g. that given in ISO 5725-2^[1];
- a mathematical method, e.g. that given in ISO/IEC Guide 98-3^[2];
- uncertainty and conformity assessment as given in ISO/IEC Guide 98-4^[3];
- JCGM 100:2008^[4].

5.2 Test apparatus

The apparatus shall have the following components (see [Figure 4](#) for the general aspect of the cut testing device).