



Designation: ~~E377-96 (Reapproved 2002)~~ Designation: E 377 - 08

## Standard Practice for Internal Temperature Measurements in Low-Conductivity Materials<sup>1</sup>

This standard is issued under the fixed designation E 377; the number immediately following the designation indicates the year of original adoption or, in the case of revision, the year of last revision. A number in parentheses indicates the year of last reapproval. A superscript epsilon ( $\epsilon$ ) indicates an editorial change since the last revision or reapproval.

### 1. Scope

1.1 This practice covers methods for instrumenting low-conductivity specimens for testing in an environment subject to rapid thermal changes such as produced by rocket motors, atmospheric re-entry, electric-arc plasma heaters, and so forth. Specifically, practices for bare-wire thermocouple instrumentation applicable to sheath-type thermocouples are discussed.

1.2 The values stated in inch-pound units are to be regarded as the standard. The metric equivalents of inch-pound units may be approximate.

1.3 *This standard does not purport to address all of the safety concerns, if any, associated with its use. It is the responsibility of the user of this standard to establish appropriate safety and health practices and determine the applicability of regulatory limitations prior to use.*

### 2. Significance and Use

2.1 Internal temperature measurements are made on both in-flight vehicles and on-ground test specimens; and, because of the importance of the temperature measurements to the design of various missile and spacecraft heat shields, it is essential that care be taken to minimize the sources of error in obtaining these measurements.

2.2 Over the past several years, the problems of using thermocouples to obtain accurate temperature measurements in low-conductivity specimens have been studied by various people to isolate the sources of error and to establish improved temperature measurement techniques. The major sources of error are listed in this document and recommended solutions to the problems are given.

### 3. General

3.1 Before proceeding to the major sources of error, it is assumed that the reader is familiar with basic methods of forming and using thermocouples<sup>2</sup>, that is (1) electric welding to form junctions, (2) maintaining cleanliness of junction area and lead wires, (3) proper selection of thermocouple type and size, corresponding to both the temperature range to be measured and the chemical compatibility with the environment, and (4) proper use of instrumentation for readout of thermocouple emf.

NOTE 1—Reader is referred to ASTM MNL 12, and STP 492, as well as Kinzie, P.A., *Thermocouple Temperature Measurement*, for needed information.

3.2 The most important sources of error beyond the above basic areas are the following:

3.2.1 The thermal disturbance produced in the low-conductivity material at the vicinity of the thermocouple sensor hot junction due to the sensor size, configuration, and installation method.

3.2.2 Electrical shorting of lead wires due to the electrical conductivity of the virgin or charred ablation material, and

3.2.3 Thermocouple sensor hot junction location accuracy.

### 4. Thermal Disturbance at Vicinity of Thermocouple Sensor Hot Junction

4.1 *General*—Ideally, to measure the true internal temperature of a solid body, it would be desirable not to have any foreign substance present that would create a disturbance affecting the natural flow of heat in the body. Since it is physically impossible to exclude the temperature sensor from the internal confines of the body, it is necessary that the thermal disturbance introduced by the sensor be minimized for accurate temperature measurements.

4.2 *Thermocouple Junction Bead Diameter:*

4.2.1 *General*—Excessively large junction beads result in lower than true temperature measurements in low-conductivity

<sup>1</sup> This practice is under the jurisdiction of ASTM Committee E21 on Space Simulation and Applications of Space Technology and is the direct responsibility of Subcommittee E21.08 on Thermal Protection.

Current edition approved Oct. 10, 1996. Published December 1996. Originally published as E377-68. Last previous edition E377-68(1992).

Current edition approved Dec. 1, 2008. Published January 2009. Originally approved in 1968. Last previous edition approved in 2002 as E 377 - 96 (2002).

<sup>2</sup> ANSI MC96.1-1975. Temperature Measurement Thermocouples (Sponsor ISA).

materials (conductivity of material less than conductivity of thermocouple wire) because of the heat sink effect of the bead.

4.2.2 *Recommendations*—To minimize this effect, the junction bead diameter should be no larger than 1.5 wire diameters for butt-welded junctions and 2 wire diameters for other types of welds.

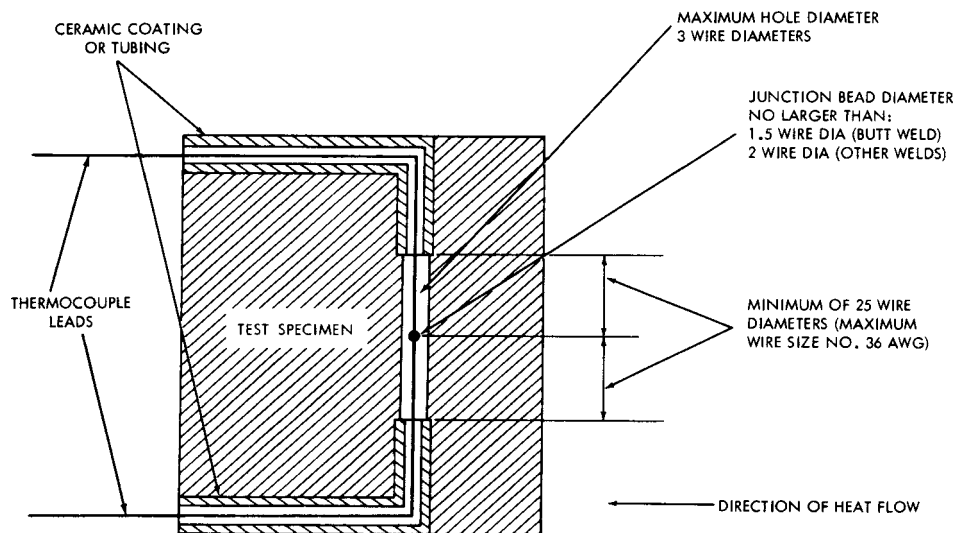

NOTE 1—If a number of thermocouples in depth are required, drill holes at varying locations on the circumference.

NOTE 2—Eliminate air pockets in junction plane by filling hole with same or similar compound as that used to make test specimen.

NOTE 3—This is a schematic representation and is not intended to be an engineering drawing.

**FIG. 1 Summary of Recommended Practices for Mounting Thermocouples—Schematic Representation for “One-Piece” Cylindrical Specimen**

(<https://standards.iteh.ai>)

### 4.3 Thermocouple Wire in Isothermal Surface of Hot Junction:

4.3.1 *General*—Because many materials have low thermal conductivity compared with those of thermocouple assemblies, it has been found that certain methods of installing sensors can produce significant errors in internal temperature measurement (1-4).<sup>3</sup> Errors of several hundred degrees are possible unless heat conduction away from the sensor hot junction, by the sensor materials, is minimized. Test results show that a thermocouple having a sufficient length of bare wire in the isothermal surface that includes the junction will minimize these errors.

4.3.2 *Recommendations*—It is therefore recommended that the configuration of the thermocouple sensor be such that the leads perpendicular to the heat flow have a length equivalent to at least 25 wire diameters on both sides of the junction in the same isothermal surface that includes the hot junction.

### 4.4 Disturbances in Vicinity of Thermocouple Sensor Hot Junctions (2-4):

4.4.1 *General*—It is important that a minimum amount of disturbance be created in the material around the thermocouple junction.

4.4.2 *Recommendations*—The disturbed material removal area (for placement of the thermocouple junction and lead wires) should be as small as possible. A maximum of No. 36 AWG gage (0.127-mm or 0.005-in.) wire should be used for the thermocouple wire from the junction and along the isothermal surface which includes the junction. Holes drilled for placement of thermocouple wires should be 3 wire diameters or smaller. It is recommended also that the difference in thermal conductivity between thermocouple assembly and the surrounding material be minimized by: (1) avoiding the use of relatively conductive (thermal) insulation (such as ceramic and fiberglass types) around the portion of wire that is located in the isothermal surface that includes the thermocouple junction, and (2) maintaining good thermal contact with the low-conductivity material by bonding the thermocouple to the specimen (thus eliminating air pockets) with the same or similar compound (such as an epoxy plastic) as that used to make the specimen.

## 5. Electrical Shorting by Conductive Char Layers

5.1 *General*—The char layer formed by most organic materials becomes highly conductive (electrically) as pyrolysis progresses. Care should be taken to avoid the possibility of electrical shorting of thermocouple lead wires not protected by proper insulation methods. Studies (1) have shown that shorting can result in temperature errors of as much as 110 C (200 F) in thermocouples which do not employ proper insulation of the lead wires.

<sup>3</sup> The boldface numbers in parentheses refer to the list of references at the end of this practice.