



# Standard Test Method for Determining Material Ignition and Flame Spread Properties<sup>1</sup>

This standard is issued under the fixed designation E1321; the number immediately following the designation indicates the year of original adoption or, in the case of revision, the year of last revision. A number in parentheses indicates the year of last reapproval. A superscript epsilon ( $\epsilon$ ) indicates an editorial change since the last revision or reapproval.

## 1. Scope

1.1 This fire test response standard determines material properties related to piloted ignition of a vertically oriented sample under a constant and uniform heat flux and to lateral flame spread on a vertical surface due to an externally applied radiant-heat flux.

1.2 The results of this test method provide a minimum surface flux and temperature necessary for ignition ( $\dot{q}''_{o,ig}$ ,  $T_{ig}$ ) and for lateral spread ( $\dot{q}''_{o,s}$ ,  $T_{s,min}$ ), an effective material thermal inertia value ( $k\rho c$ ), and a flame-heating parameter ( $\Phi$ ) pertinent to lateral flame spread.

1.3 The results of this test method are potentially useful to predict the time to ignition,  $t_{ig}$ , and the velocity,  $V$ , of lateral flame spread on a vertical surface under a specified external flux without forced lateral airflow. Use the equations in **Appendix X1** that govern the ignition and flame-spread processes and which have been used to correlate the data.

1.4 This test method is potentially useful to obtain results of ignition and flame spread for materials. Data are reported in units for convenient use in current fire growth models.

1.5 SI units are used throughout the standard.

1.6 *This standard is used to measure and describe the response of materials, products, or assemblies to heat and flame under controlled conditions, but does not by itself incorporate all factors required for fire hazard or fire risk assessment of the materials, products, or assemblies under actual fire conditions.*

1.7 *This standard does not purport to address all of the safety concerns, if any, associated with its use. It is the responsibility of the user of this standard to establish appropriate safety and health practices and determine the applicability of regulatory limitations prior to use.* For specific hazard statements, see Section 7.

## 2. Referenced Documents

### 2.1 ASTM Standards:<sup>2</sup>

**E84** Test Method for Surface Burning Characteristics of Building Materials

**E162** Test Method for Surface Flammability of Materials Using a Radiant Heat Energy Source

**E176** Terminology of Fire Standards

**E286** Test Method for Surface Flammability of Building Materials Using an 8-ft (2.44-m) Tunnel Furnace (Withdrawn 1991)<sup>3</sup>

**E648** Test Method for Critical Radiant Flux of Floor-Covering Systems Using a Radiant Heat Energy Source

**E970** Test Method for Critical Radiant Flux of Exposed Attic Floor Insulation Using a Radiant Heat Energy Source

**E1317** Test Method for Flammability of Marine Surface Finishes

### 2.2 ASTM Adjuncts: ASTM

Detailed drawings (19), construction information, and parts list (Adjunct to **E1317**)<sup>4</sup>

## 3. Terminology

3.1 *Definitions*—For definitions of terms used in this test method, refer to Terminology **E176**.

### 3.2 Definitions of Terms Specific to This Standard:

3.2.1 *backing board, n*—a noncombustible insulating board, mounted behind the specimen during actual testing to satisfy the theoretical analysis assumption of no heat loss through the specimen. It shall be roughly  $25 \pm 5$  mm thick with a density no greater than  $200 \pm 50$  kg/m<sup>3</sup>.

3.2.2 *dummy specimen, n*—a noncombustible insulating board used for stabilizing the operating condition of the equipment, roughly  $20 \pm 5$  mm in thickness with a density of  $750 \pm 100$  kg/m<sup>3</sup>.

3.2.2.1 *Discussion*—The dummy specimen is mounted in the apparatus in the position of the test specimen and removed only when a test specimen is to be inserted. For the ignition

<sup>1</sup> This test method is under the jurisdiction of ASTM Committee **E05** on Fire Standards and is the direct responsibility of Subcommittee **E05.22** on Surface Burning.

Current edition approved May 1, 2009. Published September 2009. Originally approved in 1990. Last previous edition approved in 2008 as E1321 – 08. DOI: 10.1520/E1321-09.

<sup>2</sup> For referenced ASTM standards, visit the ASTM website, www.astm.org, or contact ASTM Customer Service at service@astm.org. For *Annual Book of ASTM Standards* volume information, refer to the standard's Document Summary page on the ASTM website.

<sup>3</sup> The last approved version of this historical standard is referenced on www.astm.org.

<sup>4</sup> Available from ASTM Headquarters. Order **ADJE1317**.

tests, the dummy specimen board shall have a hole at the 50-mm position, for mounting the fluxmeter.

3.2.3 *effective thermal property, n*—thermal properties derived from heat-conduction theory applied to ignition/ flame-spread data treating the material as homogenous in structure.

3.2.4 *mirror assembly, n*—a mirror, marked and aligned with the viewing rakes, used as an aid for quickly identifying and tracking the flame-front progress.

3.2.5 *special calibration board, n*—a specially assembled noncombustible insulating board used for standardizing the operating condition of the equipment which is used only to measure the flux distribution at specified intervals along the specimen surface. It shall be roughly  $20 \pm 5$  mm in thickness with a density of  $750 \pm 100$  kg/m<sup>3</sup>.

3.2.6 *thermally thick, n*—the thickness of a medium that is large enough to have the predominate thermal (temperature) effects experienced within that distance, that is, negligible heat is lost from its unexposed side.

3.2.7 *thermal operating level, n*—the operating condition at which the radiance of the heat source produces a specified constant heat flux to some specified position at the specimen surface.

3.2.8 *viewing rakes, n*—a set of bars with wires spaced at 50-mm intervals for the purpose of increasing the precision of timing flame-front progress along the specimen.

3.3 Symbols:

- $b$  = ignition correlation parameter,  $s^{-1/2}$ .
- $C$  = flame heat transfer factor,  $m^{s/2}/kW \cdot s^{1/2}$ .
- $CF$  = ratio of radiation pyrometer signal to flux incident on dummy specimen as measured during calibration; a linear correlation is assumed,  $mV/(kW/m^2)$ .
- $F(t)$  = specimen thermal response function.
- $F(x)$  = surface flux configuration invariant,  $(kW/m^2)/mV$ .
- $h$  = heat loss coefficient,  $kW/m^2 \cdot K$ .
- $\dot{q}''_e$  = measured incident flux,  $kW/m^2$ .
- $\dot{q}''_{o,ig}$  = critical flux for ignition,  $kW/m^2$ .
- $\dot{q}''_{o,s}$  = critical flux for spread,  $kW/m^2$ .
- $t$  = time, s.
- $t^*$  = characteristic equilibrium time, s.
- $t_1$  = time at sample insertion, s.
- $t_2$  = time at ignition, s.
- $t_{ig}$  = ignition time under incident flux, s.
- $T_{ig}$  = ignition temperature, °C.
- $T_{s, min}$  = minimum temperature for spread, °C.
- $T_\infty$  = ambient and initial temperature, °C.
- $V$  = flame (pyrolysis front) velocity, m/s.
- $x$  = longitudinal position along centerline of specimen, m.
- $\Phi$  = flame heating parameter,  $(kW)^2/m^3$ .
- $kpc$  = thermal heating property,  $(kW/m^2 \cdot K)^2 \cdot s$ .
- $\epsilon$  = surface emissivity.
- $\sigma$  = Stefan-Boltzmann constant,  $kW/m^2 \cdot K^4$ .

4. Summary of Test Method

4.1 This test method consists of two procedures; one to measure ignition and one to measure lateral-flame spread. Vertically mounted specimens are exposed to the heat from a

vertical air-gas fueled radiant-heat energy source inclined at 15° to the specimen (see Fig. 1).

4.1.1 For the ignition test, a series of 155, + 0, - 5 mm by 155, + 0, - 5 mm specimens (see Fig. 1) are exposed to a nearly uniform heat flux (see Fig. 2) and the time to flame attachment, using piloted ignition (see Fig. 3), is determined.

4.1.2 For the flame spread test, a 155, + 0, - 5 mm by 800, + 0, - 5 mm specimen (see Fig. 1) is exposed to a graduated heat flux (see Fig. 2) that is approximately 5 kW/m<sup>2</sup> higher at the hot end than the minimum heat flux necessary for ignition; this flux being determined from the ignition test (see 11.2). The specimen is preheated to thermal equilibrium; the preheat time being derived from the ignition test (see 12.1). After using piloted ignition, the pyrolyzing flame-front progression along the horizontal length of the specimen as a function of time is tracked. The data are correlated with a theory of ignition and flame spread for the derivation of material flammability properties.

5. Significance and Use

5.1 This test method addresses the fundamental aspects of piloted ignition and flame spread. The procedure is suitable for the derivation of relevant material flammability parameters that include minimum exposure levels for ignition, thermal-inertia values, and flame-spread properties.

5.2 This test method is used to measure some material-flammability properties that are scientifically constant and compatible and to derive specific properties that allow the prediction and explanation of the flame-spread characteristics of materials. They are considered effective properties that are dependent on the correlations used and when combined with theory can be used over a wide range of fire conditions for predicting material ignition and flame-spread behavior.

5.3 Do not use this test method for products that do not have planar, or nearly planar, external surfaces and those products and assemblies in which physical performance such as joint separation and fastening methods has a significant influence on flame propagation in actual fire conditions.

5.4 In this procedure, the specimens are subjected to one or more specific sets of laboratory test conditions. If different test conditions are substituted or the end-use conditions are

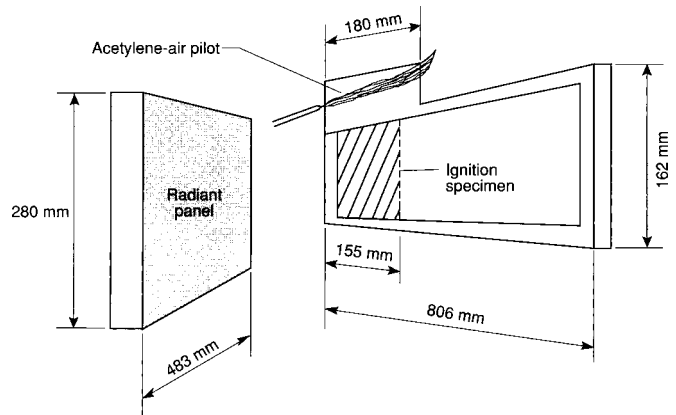

FIG. 1 Schematic of Apparatus With Ignition Specimen

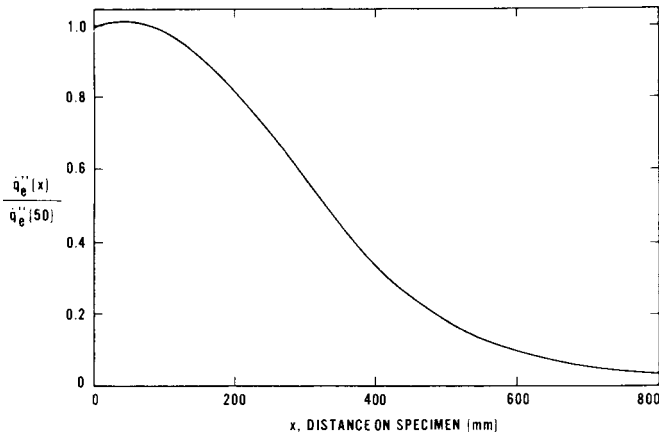
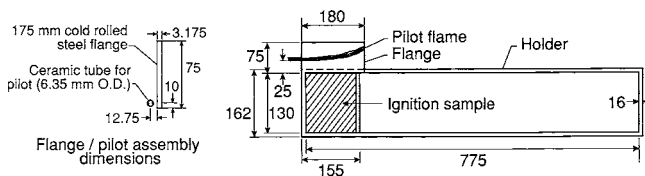

FIG. 2 Normalized Flux Over Specimen



NOTE 1—All dimensions are in millimetres.

FIG. 3 Pilot Configuration for Ignition Test

changed, it is not always possible by or from this test method to predict changes in the fire-test-response characteristics measured. Therefore, the results are valid only for the fire test exposure conditions described in this procedure (see also 1.6).

## 6. Apparatus

6.1 *Test-Equipment Fabrication*—Fig. 4 shows a photograph of the equipment as assembled ready for test. Figs. 5 and 6 show schematics of the apparatus.<sup>4</sup> These provide engineering information necessary for the fabrication of the main frame, specimen holders, stack, and other necessary parts of the equipment. Some commercially available units have added safety features that are not described in the drawings.

NOTE 1—The specimen fume stack available in some commercial models is not required for this test procedure.

6.2 A brief parts list for the test-equipment assembly includes:

6.2.1 *Main Frame* (see Fig. 5), consisting of two separate sections, the radiant-panel support frame and the specimen support frame. The two frame sections shall be joined in a manner that allows adjustments in the relative position of the radiant panel to the specimen to be made easily.

6.2.2 *Specimen Holders*, to provide for support of the specimen during test; at least two of these are required, and three prevent delays resulting from required cooling of holders prior to mounting specimens.

6.2.3 *Radiant Panel*, consisting of a radiation surface of porous refractory tiles mounted at the front of a stainless steel plenum chamber to provide a flat radiating surface of approximately 280 by 483 mm. The plenum chamber shall include baffle plates and diffusers to distribute the gas/air mixture evenly over the radiation surface. The gas/air mixture enters the plenum chamber at one of the short sides to facilitate easy

connection when the panel is mounted from the frame. A reverberatory screen (see Fig. 6) is provided immediately in front of the radiating surface to enhance the combustion efficiency and increase the radiant output.

6.2.4 *Air and Fuel Supply*, to support combustion of the radiant panel. The appropriate air and fuel flow-metering devices, gas control valves, pressure reducer, and safety controls are all mounted on the panel support frame (see Fig. 5). Requirements are as follows:

6.2.4.1 A regulated air supply of about  $8.33 \times 10^{-3} \text{ m}^3/\text{s}$  at a pressure sufficient to overcome the friction loss through the line, metering device, and radiant panel; the radiant-panel pressure drop amounts to approximately 20 to 30 Pa. A flowmeter suitable for indicating air flow over the range of 2 to  $15 \times 10^{-3} \text{ m}^3/\text{s}$  shall be provided. A flowmeter suitable for indicating methane flow rates over the range of 0.1 to  $1.1 \times 10^{-3} \text{ m}^3/\text{s}$  shall be provided.

6.2.4.2 The fuel gas used shall be either natural gas or methane. A pressure regulator shall be provided to maintain a constant supply pressure. Gas is controlled by either a manually adjusted needle valve or a venturi mixer. The venturi mixer will allow one to control the flux level of the panel by adjusting only the air valve. The fuel gas-flow requirements are roughly  $0.26 \text{ to } 1.03 \times 10^{-3} \text{ m}^3/\text{s}$  at a pressure sufficient to overcome line pressure losses.

NOTE 2—If a venturi mixer is used, the regulated air and fuel gas supply shall be sufficient for efficient operation of the venturi mixer.

6.2.5 *The Specimen Holder Support Frame Guides, Pilot Flame Holder, Fume Stack* (optional), *Flame Front Viewing Rakes, Radiation Pyrometer, and Mirror* are all assembled on the specimen support frame. The arrangement of parts on this frame is shown in Figs. 4-6.

6.2.6 *Dummy Specimen*, of noncombustible insulating board of the thickness and density specified in the test procedure, shall be mounted on the apparatus in the position of the specimen except during actual testing or calibration.

### 6.3 Instrumentation:

6.3.1 *Total Radiation Pyrometer*, compensated for its temperature variation and having a nominal sensitivity between the thermal wavelengths of 1 and  $9 \mu\text{m}$  that shall view a centrally located area on the radiant panel of about 150 by 300 mm. The instrument shall be securely mounted on the specimen support frame in such a manner that it can view the radiant panel surface oriented for specimens in the vertical position.

6.3.2 *Heat Fluxmeters*—Have available at least three fluxmeters for this test method. One of these shall be retained as a laboratory reference standard. The fluxmeters shall be of the thermopile type with a nominal range of 0 to  $50 \text{ kW}/\text{m}^2$  and have a sensitivity of approximately  $10 \text{ mV}$  at  $50 \text{ kW}/\text{m}^2$ . They shall have been calibrated to an accuracy of 5% over this range. The time constant of these instruments shall not be more than 290 ms (corresponding to a time to reach 95% of final output of not more than 1 s). The target sensing the applied flux shall occupy an area not more than 4 by 4 mm and be located flush with and at the center of the water-cooled 25-mm circular exposed metallic end of the fluxmeter. If fluxmeters of smaller diameters are to be used, these shall be inserted into a copper

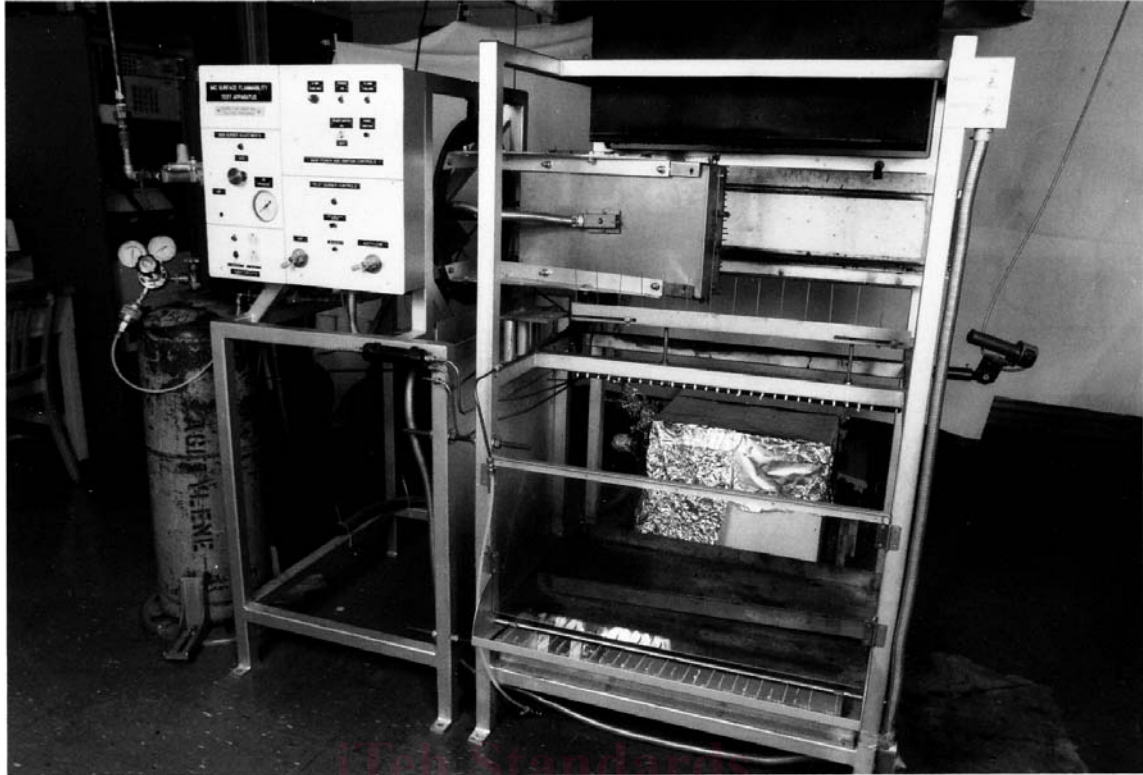

FIG. 4 General View of Apparatus

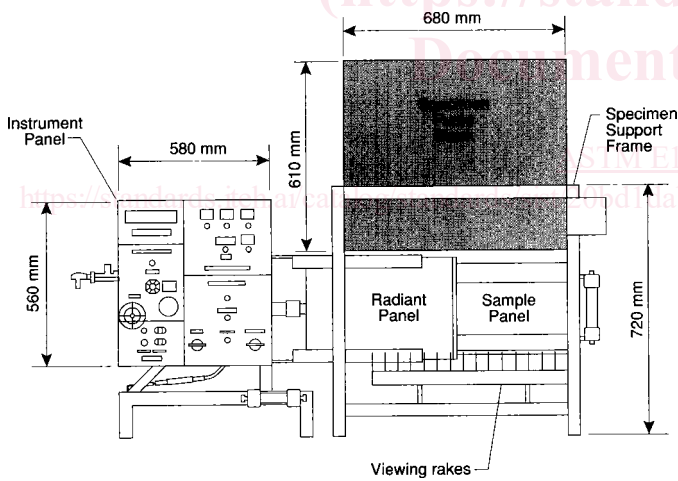

FIG. 5 Test Apparatus Main Frame, Front View

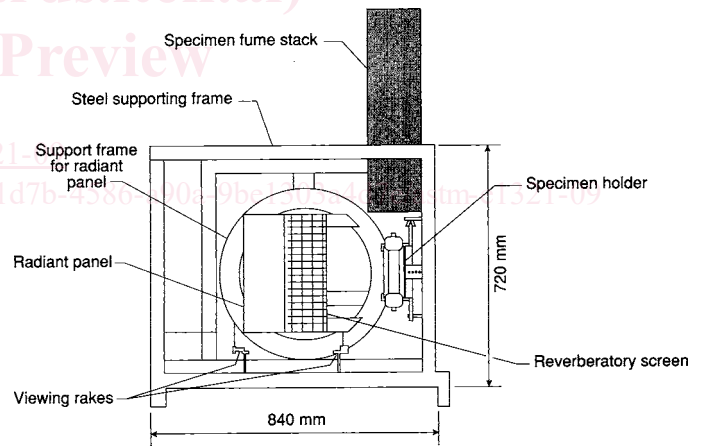

FIG. 6 Test Apparatus, Side View

sleeve of 25-mm outside diameter in such a way that good thermal contact is maintained between the sleeve and water-cooled fluxmeter body. The end of the sleeve and exposed surface of the fluxmeter shall lie in the same plane. Radiation shall not pass through any window before reaching the target.

6.3.3 *Timing Devices*, such as a chronograph, a digital clock, a stopwatch, a tape recorder, a data acquisition/computer system, or video camera shall be used to measure the times of ignition and flame-front advancement.

6.3.4 *Digital Millivoltmeter or Data Acquisition System*, capable of indicating signal changes of 10  $\mu\text{V}$  or less, is suitable for monitoring changes in operating conditions of the radiant panel.

6.4 *Space for Conducting Tests:*

6.4.1 *Test Area*, at least 45-m<sup>3</sup> volume with a ceiling height of not less than 2.5 m. The floor area supporting the apparatus shall be level.

6.4.1.1 The apparatus shall be located with a clearance of at least 1-m separation between it and the walls of the test room. No combustible finish material of ceiling, floor, or walls shall be located within 2 m of the radiant heat source.

6.4.2 *Fume Exhaust System*—An exhaust system shall be installed with a capacity for moving air and combustion products at a rate of  $0.3 \text{ m}^3/\text{s} \pm 5\%$ . Surround the exhaust system with a 1.3 by 1.3-m refractory fiber skirt hanging down to  $1.7 \pm 0.1$  m from the floor of the room. Locate the specimen support frame and radiant panel beneath this hood in such a way that all combustion fumes are withdrawn from the room.

6.4.3 *Air Supply*—Access to an exterior supply of air, to replace that removed by the exhaust system, is required. This shall be arranged in such a way that the ambient room temperature remains at  $25 \pm 5^\circ\text{C}$ .

6.4.4 *Room Drafts*—Measurements shall be made of air speeds near a dummy specimen in the vertical position while the fume exhaust system is operating but the radiant panel and its air supply are turned off. At a distance of 100 mm from the panel, perpendicular to the lower edge and at midlength of the panel, the air flow shall not exceed 0.2 m/s in any direction.

## 7. Hazards

7.1 Safeguards shall be installed in the panel fuel supply system to guard against a gas air fuel explosion in the test chamber. The safeguards shall include, but are not limited to, one or more of the following: a gas feed cut-off activated when the air supply fails; a flame sensor directed at the panel surface that stops fuel flow when the panel flame goes out; and a heat detector mounted in contact with the radiant panel plenum that is activated when the panel temperature exceeds safe limits. Manual reset is a requirement of any safeguard system used.

7.2 The exhaust system must be so designed and operated that the laboratory environment is protected from smoke and gas. The operator shall be instructed on ways to minimize exposure to combustion products by following sound safety and industrial hygiene practices. For example, ensure that the exhaust system is working properly and wear appropriate clothing including gloves, safety glasses, breathing apparatus (when hazardous fumes are expected), etc.

7.3 During this test, very high irradiances are generated that are capable of igniting some clothing following even brief exposures. Take precautions to avoid ignitions of this type.

## 8. Test Specimens

8.1 The specimens selected for testing shall be representative of the product as it is intended for use.

8.2 *Specimen Thickness*—The requisite specimen shall be thermally thick. Materials and composites of normal thickness 50 mm or less shall be tested using their full thickness.

NOTE 3—Some commercially available units may be used for testing specimens with thickness of  $75, +0, -3$  mm.

8.2.1 *Composites*—Assemblies shall be as specified in 8.2. However, where thin materials or composites are used in the fabrication of an assembly, it is possible that the presence of an air gap, or the nature of any underlying construction, or both, significantly affects the flammability characteristics of the

exposed surface. Use the same substrate for testing as used during field installation. If that substrate cannot be used or if it is unknown, a reference substrate must be used in its place. The standard reference substrate is fiber-reinforced cement board with a nominal thickness of 6.3 mm, a density of  $1762 \pm 80 \text{ kg/m}^3$ , and uncoated. When testing a thin material or a composite assembly, ensure that no air gap exists between the specimen and the substrate material.

8.2.2 Specimens shall be tested in the form of intended use.

8.3 *Specimen Size*:

8.3.1 *Ignition Test*—The specimens shall be 155, +0, -5 by 155, +0, -5 mm and shall be representative of the product.

8.3.2 *Flame Spread Test*—The specimens shall be 155, +0, -5 by 800, +0, -5 mm and shall be representative of the product.

8.4 *Number of Specimens*:

8.4.1 *Ignition Test*—Obtaining the ignition-flux profile requires the testing of six to twelve specimens.

8.4.2 *Flame Spread Test*—Test three specimens for each different exposed surface of the product tested.

## 9. Calibration of Apparatus

9.1 Perform mechanical, electrical, and thermal calibrations as described in Annex A1. Perform these adjustments and calibrations following initial installation of the apparatus and at other times as the need arises.

9.2 *Monthly Verification*—In a continuous program of tests, the flux distribution shall be determined not less than once a month. Where the time interval between tests is greater than one month, the flux distribution shall be determined at the start of the test series.

9.3 *Continuous Monitoring of Operation*—A dummy specimen shall remain mounted in the position normally occupied by a specimen whenever the equipment is in stand-by operation. This is a necessary condition of the continuous monitoring procedure that is accomplished by measuring the following:

9.3.1 The millivolt signal from a heat fluxmeter positioned 50 mm from the exposed end of a dummy specimen, and

9.3.2 The millivolt signal from the radiation pyrometer mounted securely on the specimen holder frame facing the surface of the radiant panel.

9.3.3 Either of these measurement methods is satisfactory for determining that the required thermal operating level has been achieved. Satisfactory results require that both signals show no drift for 3 min prior to test. The observed operating level of the panel from either the radiation pyrometer or the fluxmeter shall correspond, within 2%, to the similarly measured conditions during the calibration procedure mentioned in A1.3.

## 10. Conditioning

10.1 *Specimen Conditioning*—Before testing, condition the specimens to constant moisture content at a temperature of  $23 \pm 3^\circ\text{C}$  and a relative humidity of  $50 \pm 5\%$ . Constant moisture content is considered to be reached when, following

two successive weighings, carried out at 24-h intervals, the measured mass does not differ by more than 0.1 % of the mass of the specimen.

10.2 *Specimen Preparation*—Prior to insertion in the specimen holder, wrap the back and edges of the specimen in a single sheet of 0.2 mm thick aluminum foil. When inserted in the specimen holder, back each specimen with a 25-mm sheet of noncombustible refractory insulating material of the same lateral dimensions, density, and thermal characteristics as the backing board.

10.2.1 *Flame Spread Test*—Using an appropriate marker such as chalk, or a soft pencil, draw a line along the center horizontal length of the exposed face of each specimen. Make vertical markings at 25-mm (or less) increments as an aid in tracking the flame-front progress.

## 11. Procedures

11.1 *General*—This test method involves mounting conditioned specimens in a well defined flux field and measuring ignition times, spread of flame, and position of final extinguishment. Therefore, these procedures assume that the apparatus has been prepared and calibrated as described in Section 10 and Annex A1.

11.1.1 Start the fume exhaust system.

11.1.2 Slide the dummy specimen into the apparatus.

11.1.3 Turn on the regulated air supply to the radiant panel.

11.1.4 Position ignitor approximately 2 cm in front of the radiant-panel surface.

11.1.5 Turn on the gas supply to ignite the radiant panel.

11.1.6 Adjust the air/gas flow for the appropriate thermal operating level by referencing the millivolt signal from the water cooled heat fluxmeter that monitors the irradiance at the 50-mm position on the dummy specimen or the millivolt signal from the total-radiation pyrometer that monitors the radiant-panel surface, or both. Make the adjustments to the output of the radiant panel by first adjusting the air supply and then, if necessary, adjusting the gas supply. Allow at least 15 min for the radiant panel to reach equilibrium.

11.1.7 If the heat fluxmeter signal is used in establishing the appropriate operating level, turn on the cooling water to the fluxmeter prior to positioning the fluxmeter in the special 50-mm dummy specimen. The cooling water shall be within  $\pm 3^\circ\text{C}$  of room temperature. Use the dummy specimen fabricated to accommodate the fluxmeter at the 50-mm position.

### 11.2 Ignition Test Procedure:

11.2.1 Adjust the thermal operating level for an external flux  $\{\dot{q}''_e(x)\}$  of 30 kW/m<sup>2</sup> to the specimen surface at the 50-mm position.

11.2.2 Ignite the pilot; adjust the air/acetylene control valves so that a light-blue conical flame extends approximately 180 mm lengthwise across the contiguous wall flange at the top of the specimen holder (see Fig. 3).

11.2.3 Check and, if necessary, readjust the apparatus to the appropriate thermal operating level. Allow the apparatus to stabilize for at least 3 min.

11.2.4 Record the output of the radiation pyrometer for the purpose of monitoring the radiant panel operating level during testing. A sample data-log format is shown in Fig. 7.

**IGNITION DATA LOG**

Date: \_\_\_\_\_ Test Number: \_\_\_\_\_ Time: \_\_\_\_\_

Orientation: \_\_\_\_\_

Pilot Configuration: \_\_\_\_\_

Specimen: \_\_\_\_\_

Size: \_\_\_\_\_ mm Humidity: \_\_\_\_\_ RH %

Specimen Backing: \_\_\_\_\_ Density: \_\_\_\_\_ kg/m<sup>2</sup>

Comment: \_\_\_\_\_

Flux Sensor No: \_\_\_\_\_ Calibration Factor: \_\_\_\_\_

Flux Sensor Reading: \_\_\_\_\_ mV \_\_\_\_\_ kW/m<sup>2</sup> ( $\dot{q}''_e$ )

Pyrometer Reading: \_\_\_\_\_ mV \_\_\_\_\_ kW/m<sup>2</sup> ( $\dot{q}''_e$ )

Comments: \_\_\_\_\_

Time to:

Ignition of upper flame \_\_\_\_\_ s

Oscillating flames \_\_\_\_\_ s

Attached flame ( $t_{ig}$ ) \_\_\_\_\_ s

Comments: \_\_\_\_\_

FIG. 7 Data Logging Format Sample, Ignition Test

11.2.5 Record the external flux  $\{\dot{q}''_e(x)\}$  as determined from the output of the fluxmeter at the 50-mm position.

11.2.6 Record the ambient room temperature,  $T_\infty$ .

11.2.7 Remove the fluxmeter from the dummy specimen.

11.2.8 Within a 10-s interval, remove the holder containing the dummy specimen from the apparatus and insert the holder containing the test specimen. Using a suitable instrument such as a stopwatch, audiovisual instrument, data acquisition/computer system, chronograph, or strip chart recorder, or any combination thereof, record the time ( $t_1$ ) when the test specimen is fully in place and the time ( $t_2$ ) of flame attachment to the specimen surface. Time of ignition ( $t_{ig}$ ) is defined as the time after specimen insertion to the time of flame attachment to the specimen surface ( $t_2 - t_1$ ). Terminate the test at 20 min if ignition does not occur.

11.2.9 Record the time to ignition,  $t_{ig}$ .

11.2.10 If ignition occurred, readjust the external flux  $\{\dot{q}''_e(x)\}$  at the 50-mm position downward using increments of approximately 5 kW/m<sup>2</sup> and repeat the test until a flux at which no ignition occurs has been identified. If ignition did not occur, readjust the external flux  $\{\dot{q}''_e(x)\}$  at the 50-mm position upward (using increments of approximately 5 kW/m<sup>2</sup>), and repeat the test (using fresh specimen(s)) until a minimum flux at which ignition occurs has been identified.

11.2.11 Determine a minimum flux for ignition ( $\dot{q}''_{o,ig}$ ) by bracketing within  $\pm 2$  kW/m<sup>2</sup> the fluxes for ignition/no ignition.

11.2.12 Repeat 11.2.1-11.2.9 adjusting the external flux  $\{\dot{q}''_e(x)\}$  at the 50-mm position upward (using increments of approximately 10 kW/m<sup>2</sup>), until an ignition time flux profile (Fig. 8) has been determined for fluxes  $\{\dot{q}''_e(50)\}$  between the minimum flux for ignition ( $\dot{q}''_{o,ig}$ ) and 65 kW/m<sup>2</sup>. Depending