



Designation: F2388 – 09

Standard Consumer Safety Specification for Baby Changing Tables for Domestic Use¹

This standard is issued under the fixed designation F2388; the number immediately following the designation indicates the year of original adoption or, in the case of revision, the year of last revision. A number in parentheses indicates the year of last reapproval. A superscript epsilon (ϵ) indicates an editorial change since the last revision or reapproval.

INTRODUCTION

This consumer safety specification addresses incidents associated with baby changing tables identified by the U.S. Consumer Product Safety Commission (CPSC). Incidents involved collapse, falls from the table, and entrapment in structural members.

In response to incident data collected by CPSC, this consumer safety specification attempts to minimize the risk of injury and death due to: (1) falls from changing tables, (2) failure of structural or mechanical components, (3) instability and entrapment in openings in the table structure. This specification also contains requirements for warnings and instructional materials directed to parents or caregivers.

1. Scope

1.1 This consumer safety specification covers performance requirements, test methods, and labeling requirements to promote the safe use of baby changing tables and other changing surfaces such as contoured changing pads and add-on changing units that are sold separately for use on furniture products other than changing tables.

1.2 This specification covers products sold for domestic use for children up to a weight of 30 lb (13.6 kg).

1.3 Changing tables and other changing products sold separately, such as contoured changing pads and add-on changing units shall meet all applicable performance and labeling requirements.

1.4 No changing table, contoured changing pad, or add-on changing unit produced after the approval date of this specification shall, either by label or other means, indicate compliance with this specification unless it conforms to all applicable requirements contained herein, before, and after all testing.

1.5 The values stated in inch-pound units are to be regarded as standard. The values given in parentheses are mathematical conversions to SI units that are provided for information only and are not considered standard.

1.6 The following precautionary caveat pertains only to the test method portion in Section 7 of this specification. *This standard does not purport to address all of the safety concerns,*

if any, associated with its use. It is the responsibility of the user of this standard to establish appropriate safety and health practices and determine the applicability of regulatory requirements prior to use.

2. Referenced Documents

2.1 ASTM Standards:²

D3359 Test Methods for Measuring Adhesion by Tape Test
F406 Consumer Safety Specification for Non-Full-Size
Baby Cribs/Play Yards

F963 Consumer Safety Specification for Toy Safety

2.2 Federal Regulations:³

16 CFR 1303 Ban of Lead-Containing Paint and Certain
Consumer Products Bearing Lead-Containing Paint

16 CFR 1500 Hazardous Substances Act Regulations including
sections:

16 CFR 1500.48 Technical Requirements for Determining a
Sharp Point in Toys or Other Articles Intended for Use by
Children Under Eight Years of Age

16 CFR 1500.49 Technical Requirements for Determining a
Sharp Metal or Glass Edge in Toys or Other Articles
Intended for Use by Children Under Eight Years of Age

16 CFR 1500.50-.52 Test Methods for Simulating Use and
Abuse of Toys and Other Articles Intended for Use by
Children

16 CFR 1501 Method for Identifying Toys and Other Ar-
ticles Intended for Use by Children Under Three Years of

¹ This consumer safety specification is under the jurisdiction of ASTM Committee F15 on Consumer Products and is the direct responsibility of Subcommittee F15.18 on Cribs, Toddler Beds, Play Yards, Bassinets, Cradles and Changing Tables.

Current edition approved Aug. 1, 2009. Published September 2009. Originally approved in 2004. Last previous edition approved in 2008 as F2388 – 08a. DOI: 10.1520/F2388-09.

² For referenced ASTM standards, visit the ASTM website, www.astm.org, or contact ASTM Customer Service at service@astm.org. For *Annual Book of ASTM Standards* volume information, refer to the standard's Document Summary page on the ASTM website.

³ Available from U.S. Consumer Product Safety Commission (CPSC), Washington, D.C. 20207, website: www.cpsc.gov.

Age Which Present Choking, Aspiration or Ingestion Hazards Because of Small Parts

3. Terminology

3.1 Definitions of Terms Specific to This Standard:

3.1.1 *add-on changing unit, n*—a rigid addition to or separate product used in conjunction with an item of furniture that provides a changing surface and barriers to prevent the infant from rolling off the product when a diaper is being changed.

3.1.2 *barrier, n*—any material or surface of the contoured changing pad, add-on changing unit, or changing table intended to prevent a child from rolling or falling off the changing surface.

3.1.3 *changing pad, n*—a flat or contoured pad specifically designed for the purpose of changing the diaper of a child with a body weight of up to 30 lb (13.6 kg) on an elevated surface. The child is placed on the pad during the process of changing.

3.1.4 *changing surface, n*—the surface that is in direct contact with the child when the changing table, contoured changing pad, or add-on changing unit is in the manufacturer's recommended use position.

3.1.5 *changing table, n*—an elevated, freestanding structure generally designed to support and retain a child with a body weight of up to 30 lb (13.6 kg) in a horizontal position for the purpose of allowing a caregiver to change the child's diaper. Changing tables may convert from or to other items of furniture, such as, but not limited to, a dresser, desk, hutch, bookshelf, or play yard, may have pull-out or drop-down changing surfaces, and may provide storage for diapers and diaper products.

3.1.6 *conspicuous, adj*—label that, when the changing table, changing pad, or add-on changing unit is in a manufacturer's recommended use position, is visible to a person standing in front of the table in a position normally associated with the task of changing a child's diaper.

3.1.7 *contoured changing pad, n*—a changing pad designed for use on an elevated surface which incorporates barriers to prevent a child from rolling off the changing surface.

3.1.8 *manufacturer's recommended use position(s), n*—any position that is presented as a normal, allowable, or acceptable configuration for the use of the product as a diaper changer by the manufacturer in any descriptive or instructional literature. This specifically excludes positions that the manufacturer shows in a like manner in its literature to be unacceptable, unsafe, or not recommended.

3.1.9 *non-paper label, n*—any label (material such as plastic or metal) which either will not tear without the aid of tools, or tears leaving a sharp defined edge.

3.1.10 *paper label, n*—any label material that tears without the aid of tools and leaves a fibrous edge.

4. Calibration and Standardization

4.1 All testing shall be conducted on a concrete floor, which may be covered with 1/8-in. (3-mm) thick vinyl flooring cover, unless test instructs differently.

4.2 Unless otherwise noted, the product shall be completely assembled in accordance with the manufacturer's instructions, including any pad supplied by the manufacturer or pad the manufacturer requires, for product to be used as a changing table.

4.3 No testing shall be conducted within 48 h of manufacturing.

4.4 The product to be tested shall be placed in a room with ambient temperature of $73 \pm 9^\circ\text{F}$ ($23 \pm 5^\circ\text{C}$) for at least 1 h prior to testing. Testing shall then be conducted within this temperature range.

4.5 All testing required by this specification shall be conducted on the same unit.

5. General Requirements

5.1 *Sharp Points and Edges*—There shall be no hazardous sharp points or sharp edges as defined by 16 CFR 1500.48 and 16 CFR 1500.49 before and after testing to this specification.

5.2 *Small Parts*—There shall be no small parts as defined by 16 CFR 1501 before testing or liberated as a result of testing to this specification.

5.3 *Surface Coatings*—The paint or surface coating on the product shall comply with 16 CFR 1303.

5.4 *Wood Parts*—Prior to testing, any exposed wood parts shall be smooth and free from splinters.

5.5 *Openings*—Holes or slots that extend entirely through a wall section of any rigid material less than 0.375-in. (9.53-mm) thick and admit a 0.210-in. (5.33-mm) diameter rod shall also admit a 0.375-in. (9.53-mm) diameter rod. Holes or slots that are between 0.210 in. (5.33 mm) and 0.375 in. (9.53 mm) and have a wall thickness less than 0.375 in. (9.53 mm) but are limited in depth to 0.375-in. (9.53-mm) maximum by another rigid surface shall be permissible (see Fig. 1). The product shall be evaluated in all manufacturer's use positions.

5.6 Changing tables or add-on changing units intended to be attached to a non-full-size crib/play yard shall conform to the requirements of this specification and Consumer Safety Specification F406 when attached in the manufacturer's recommended use position.

5.7 *Toys*—Toy accessories attached to, removable from, or sold with a changing table, contoured changing pad, or an add-on changing unit, as well as their means of attachment, must meet applicable requirements of Consumer Safety Specification F963.

6. Performance Requirements

6.1 *Protective Components*—If a child can grasp protective components between the thumb and forefinger, or teeth, such as caps, sleeves, or plugs used for protection from sharp edges, points, or entrapment of fingers or toes, or if there is at least a 0.040-in. (1.00-mm) gap between the protective component and its adjacent parent component, such protective component shall not be removed when tested in accordance with 7.1.

6.2 *Structural Integrity*—When tested in accordance with 7.2, there shall be no breakage of the unit, nor shall it fail to

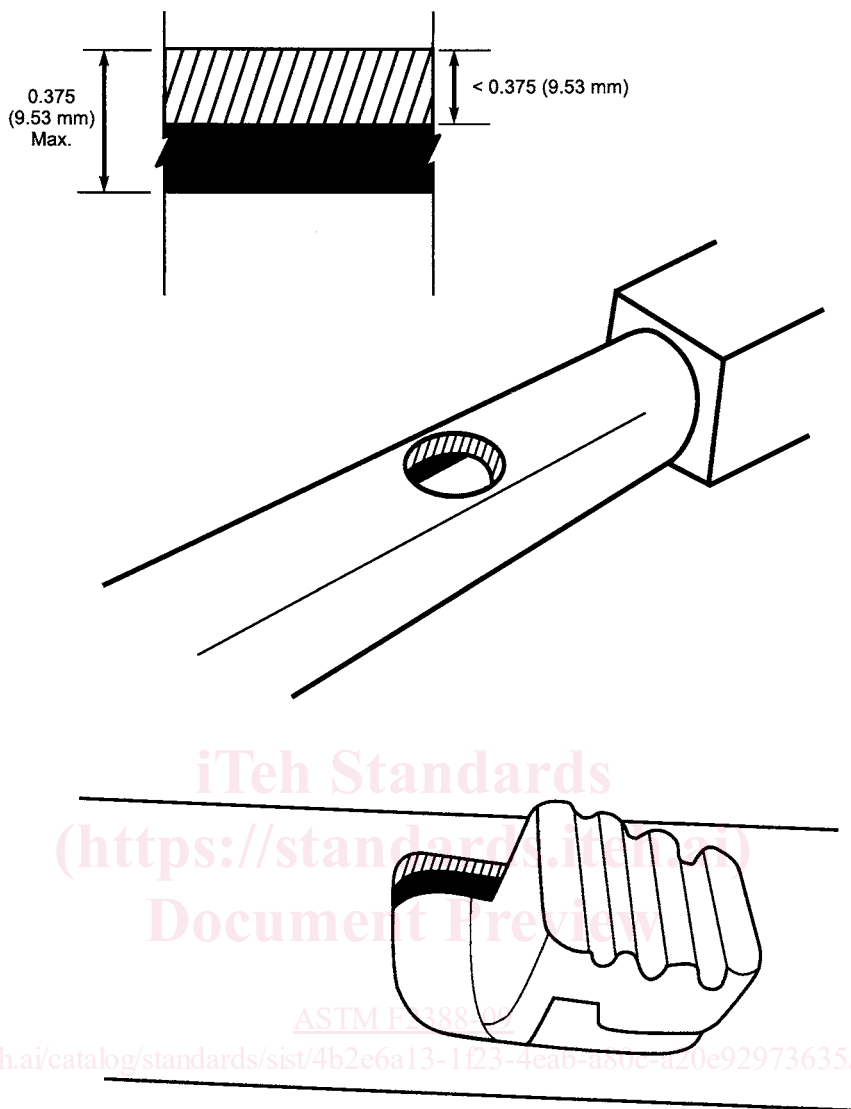

FIG. 1 Opening Examples

conform with any other requirements in this specification before and after all testing.

NOTE 1—Contoured changing pads and add-on changing units that are sold separately are exempt from this requirement.

6.3 *Stability*—When tested in accordance with 7.3, the unit shall not tip over.

NOTE 2—Contoured changing pads and add-on changing units that are sold separately are exempt from this requirement.

6.4 *Barriers*:

6.4.1 Each changing table, contoured changing pad, or add-on changing unit shall include barriers as an integral part of the product.

6.4.2 For changing tables with a flat changing surface, barriers shall be provided on all sides of the changing surface.

6.4.3 Changing tables and add-on changing units with a contoured changing pad and contoured changing pads sold separately shall have barriers on the two opposing long sides.

6.4.4 When tested in accordance with 7.4, barriers shall prevent the test cylinder from falling from the changing surface and shall not break or fail to conform with the requirements of Section 5.

6.4.5 *Retention of Contoured Changing Pads and Add-on Changing Units*—This requirement applies to contoured changing pads and other add-on changing units sold with or independent of a changing table.

NOTE 3—Non-full-size cribs/play yards are exempt from this requirement, as they must comply with the retention and opening/entrapment requirements specified in Consumer Safety Specification F406, “Entrapment in Attachments” Section.

6.4.6 When tested in accordance with 7.4, a contoured changing pad or add-on changing unit shall not shift or slide more than 1 in. (25 mm) in any direction from its original position.

6.4.6.1 If tabs or straps are provided to secure the contoured changing pad, when tested in accordance with 7.4, the pad shall

15 lbf (67N) MAX TENSION

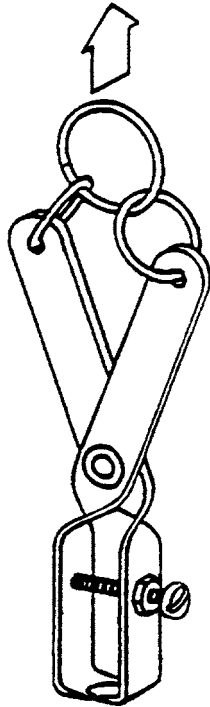

FIG. 2 Tension Test Clamp

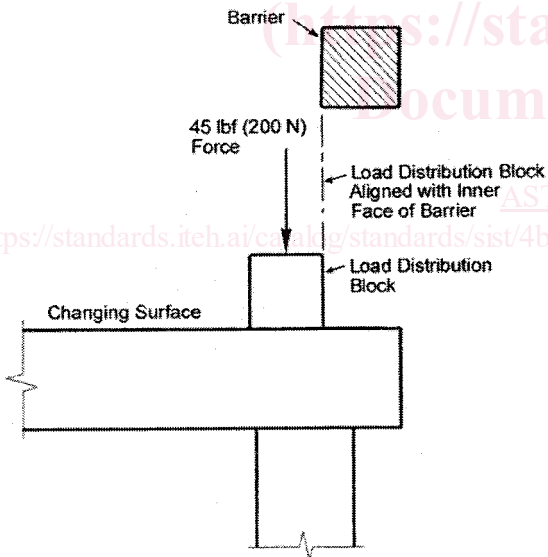

FIG. 3 Stability Test

not shift or slide more than 1 in. (25 mm) in a direction opposite from the edge containing attachment tabs or straps.

6.5 *Entrapment in Enclosed Openings*—When tested in accordance with 7.5, there shall be no completely bounded openings (openings surrounded by a boundary on all sides) anywhere in the structure of a changing table that permit the free passage of the torso probe shown in Fig. 5 unless they also permit the free passage of the 9.0-in. (229-mm) diameter probe shown in Fig. 6.

6.6 *Entrapment by Shelves*—When tested in accordance with the procedure in 7.6, any shelf above 4.3 in. (109 mm) from the floor that, because its movement may expose an opening that could entrap a child’s head, shall not permit the entire passage of the small head probe shown in Fig. 7 through the exposed opening. Excluded from this requirement are pullout drawers and shelves enclosed within a cabinet equipped with a door(s).

7. Test Methods

7.1 *Removal of Protective Components*—Protective components shall be tested in accordance with each of the following methods in the sequence listed.

7.1.1 *Torque Test:*

7.1.1.1 Gradually apply a torque of 3 lbf-in. (0.3 N-m) within a period of 5 s in a clockwise direction until either the component rotates 180° from the original position or a torque of 3 lbf-in (0.3 N-m) is attained. The torque or maximum rotation shall be maintained for an additional 10 s. The torque shall then be removed and the protective component permitted to return to a relaxed condition. This procedure shall then be repeated in a counterclockwise direction.

7.1.2 *Tension Test:*

7.1.2.1 Attach a force gage to the cap, sleeve or plug by means of any suitable device. For protective components that cannot reasonably be expected to be grasped between thumb and forefinger or teeth on their outer diameter but have a gap of at least 0.040 in. (1.00 mm) between the rear surface of the protective component and the structural member of the changing table to which they are attached, a clamp such as the one shown in Fig. 2 may be a suitable device.

7.1.2.2 Assure that the attachment device does not compress or expand the protective component so that it hinders any possible removal.

7.1.2.3 Gradually apply a 15-lbf (67-N) force in the direction that would normally be associated with the removal of the protective component over a 5-s period and hold for an additional 10 s.

7.2 *Structural Integrity*—Assemble the unit in accordance with the manufacturer’s assembly instructions. Place the unit on the test floor, center a 6 by 6 in. (150 by 150 mm) wood block on the changing surface and gradually apply a 100 lb (45.4 kg) weight onto the wood block within a period of 5 s. Maintain the weight for an additional period of 60 s.

7.3 *Stability*—Remove the changing pad if it is detachable. Gradually apply a 45-lbf (200-N) vertically downward force to the edge of the changing surface that is deemed most likely to cause tipping. The force shall be applied to the center of a load distribution block (see Fig. 3) fabricated from a rigid material 3/4-in. (19-mm) wide by 3/4-in. (19-mm) thick by 3-in. (80-mm) long. The force shall be applied with the 3-in. (80-mm) dimension of the block aligned with the edge of the changing surface (see Fig. 3). The force shall be applied gradually within a period of 5 s and maintained for an additional 10 s.

7.4 *Barrier Structural Integrity and Retention Tests:*

7.4.1 *Test Equipment:*

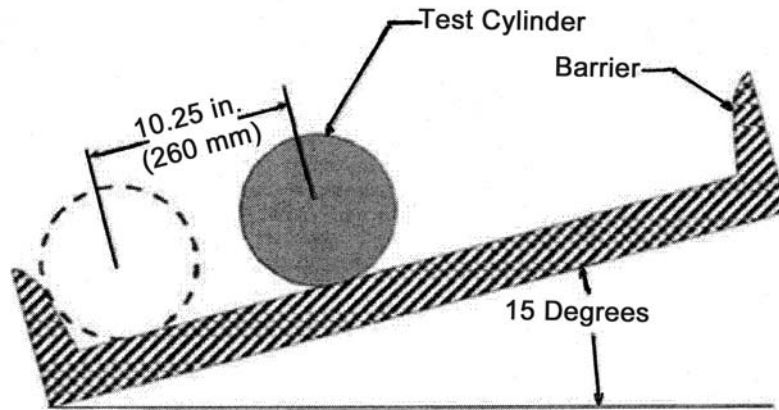
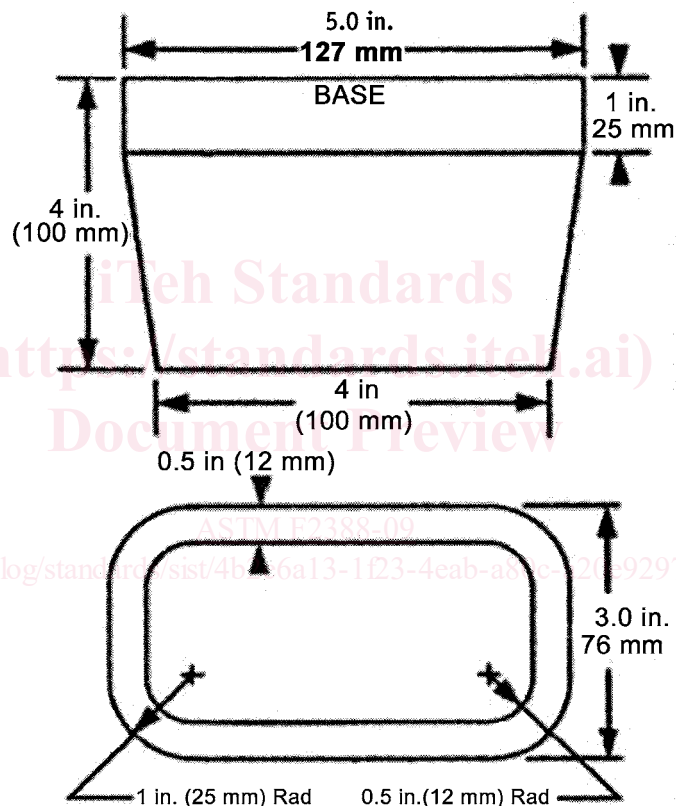

FIG. 4 Barrier Retention Test



Material: Any rigid Material

FIG. 5 Torso Probe

7.4.1.1 Rigid cylinder with a diameter of 8 in. (200 mm), a length of 12 in. (300 mm), and a mass of 33 lb (15 kg).

7.4.1.2 Timing device capable of displaying seconds.

7.4.2 Changing tables or add-on changing units that mount to the support surface.

7.4.2.1 Test procedure for changing tables with integral barriers (barriers independent of the changing pad) or add-on changing units with integral barriers (barriers independent of the changing pad) that mount to the support surface on an item of furniture in the manufacturer's recommended use position:

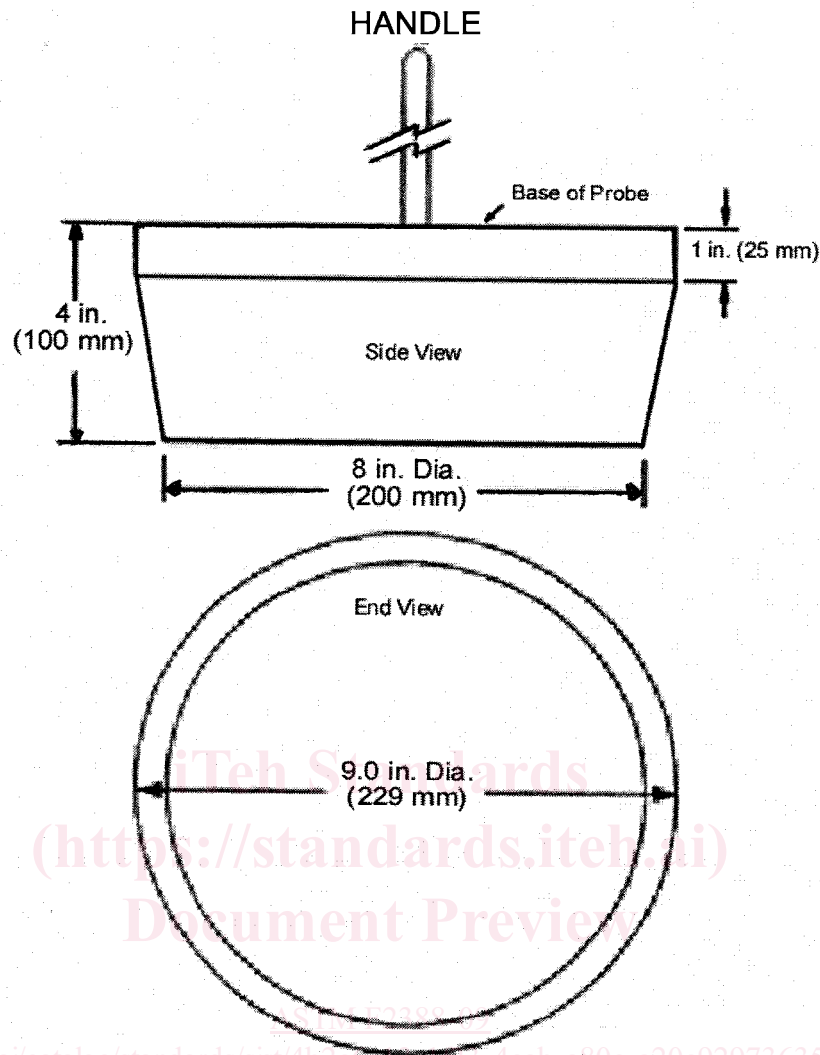

Material: Any rigid material

FIG. 6 Large Head Probe

NOTE 4—1. Changing tables sold with or add-on changing units for use with play yards, cribs, etc. are excluded from this requirement as they are covered under 7.4.5.

NOTE 5—2. For purposes of this test, an add-on changing unit that mounts to the support surface on an item of furniture in the manufacturer's use position and are recommended for use ONLY on specific furniture model(s) shall be tested on the specified models.

(1) Place the changing table or add-on changing unit in the manufacturer's recommended use position on a test surface inclined 15° to the horizontal. Secure the changing table to the test surface to prevent movement or overturning. Secure the add-on changing unit to the test surface per the manufacturer's instructions.

(2) Place the pad provided with the product or a pad of the largest dimensions specified by the manufacturer on the changing surface.

(3) Position the test cylinder in such a way that its longitudinal axis is parallel to the safety barrier to be tested and resting on the pad, against that barrier.

(4) Roll the cylinder away from the barrier and release it when the longitudinal axis is at a distance of 10.25 in. (260 mm) from its at-rest position against the barrier (see Fig. 4) or until it contacts the opposite barrier, whichever distance is less.

(5) Repeat the testing in this section for the barrier on the other sides of the changing table or add-on changing unit.

7.4.3 Contoured changing pads sold with a changing table.

7.4.3.1 Test procedure for changing tables sold with a contoured changing pad surface (barriers integrated into the changing pad).

(1) Secure the changing table to a platform that can be inclined ±15° to the horizontal with the long axis of the trough of the changing surface parallel to the tilting axis of the platform.

(2) *Preconditioning (Aging)*: Place test cylinder on the contour surface of the pad in such a way that its longitudinal axis is parallel to the wall or barrier to be tested. Manually roll