**Ships and marine technology —
Technical requirements for dry-
disconnect/connect couplings for
bunkering liquefied natural gas**

*Navires et technologie maritime — Exigences techniques relatives au
couplage de connexion et de déconnexion à sec pour le soutage de gaz
naturel liquéfié*

iTeh STANDARD PREVIEW
(standards.iteh.ai)

[ISO 21593:2019](https://standards.iteh.ai/catalog/standards/sist/534a6d04-60fb-4c89-aca8-199136e76a9b/iso-21593-2019)

<https://standards.iteh.ai/catalog/standards/sist/534a6d04-60fb-4c89-aca8-199136e76a9b/iso-21593-2019>



iTeh STANDARD PREVIEW
(standards.iteh.ai)

ISO 21593:2019

<https://standards.iteh.ai/catalog/standards/sist/534a6d04-60fb-4c89-aca8-199136e76a9b/iso-21593-2019>



COPYRIGHT PROTECTED DOCUMENT

© ISO 2019

All rights reserved. Unless otherwise specified, or required in the context of its implementation, no part of this publication may be reproduced or utilized otherwise in any form or by any means, electronic or mechanical, including photocopying, or posting on the internet or an intranet, without prior written permission. Permission can be requested from either ISO at the address below or ISO's member body in the country of the requester.

ISO copyright office
CP 401 • Ch. de Blandonnet 8
CH-1214 Vernier, Geneva
Phone: +41 22 749 01 11
Fax: +41 22 749 09 47
Email: copyright@iso.org
Website: www.iso.org

Published in Switzerland

Contents

	Page
Foreword	iv
1 Scope	1
2 Normative references	1
3 Terms and definitions	1
4 General requirements	3
4.1 General.....	3
4.2 Basic design principle.....	3
4.3 Design parameters.....	4
4.4 Functional requirements.....	5
4.5 Internal valve.....	5
4.6 Protective cap/plug.....	6
4.7 Handle.....	6
5 Materials	6
5.1 General.....	6
5.2 Body of coupling.....	6
5.3 Bolting.....	6
5.4 Spring.....	6
5.5 Seals.....	6
5.6 Welding.....	6
6 Interface types and dimensions	6
7 Marking	9
8 Testing	9
8.1 General.....	9
8.2 Ambient test conditions.....	10
8.3 Cryogenic test conditions.....	10
8.4 Test arrangement.....	11
8.5 Shell tightness at ambient temperature.....	12
8.6 Shell strength at ambient temperature.....	12
8.7 Internal valve tightness at ambient temperature.....	12
8.8 Internal valve strength at ambient temperature.....	13
8.9 Shell tightness at minimum working temperature.....	13
8.10 Internal valve tightness at minimum working temperature.....	13
8.11 Operation test at minimum working temperature.....	14
8.12 Electrical conductivity.....	14
8.13 Manual force at cold conditions under frost.....	14
8.14 Bending test.....	14
8.15 Drop test.....	15
8.16 Endurance test.....	15
8.17 High-pressure test.....	16
Bibliography	17

Foreword

ISO (the International Organization for Standardization) is a worldwide federation of national standards bodies (ISO member bodies). The work of preparing International Standards is normally carried out through ISO technical committees. Each member body interested in a subject for which a technical committee has been established has the right to be represented on that committee. International organizations, governmental and non-governmental, in liaison with ISO, also take part in the work. ISO collaborates closely with the International Electrotechnical Commission (IEC) on all matters of electrotechnical standardization.

The procedures used to develop this document and those intended for its further maintenance are described in the ISO/IEC Directives, Part 1. In particular, the different approval criteria needed for the different types of ISO documents should be noted. This document was drafted in accordance with the editorial rules of the ISO/IEC Directives, Part 2 (see www.iso.org/directives).

Attention is drawn to the possibility that some of the elements of this document may be the subject of patent rights. ISO shall not be held responsible for identifying any or all such patent rights. Details of any patent rights identified during the development of the document will be in the Introduction and/or on the ISO list of patent declarations received (see www.iso.org/patents).

Any trade name used in this document is information given for the convenience of users and does not constitute an endorsement.

For an explanation of the voluntary nature of standards, the meaning of ISO specific terms and expressions related to conformity assessment, as well as information about ISO's adherence to the World Trade Organization (WTO) principles in the Technical Barriers to Trade (TBT), see www.iso.org/iso/foreword.html.

This document was prepared by Technical Committee ISO/TC 8, *Ships and marine technology*.

Any feedback or questions on this document should be directed to the user's national standards body. A complete listing of these bodies can be found at www.iso.org/members.html.

Ships and marine technology — Technical requirements for dry-disconnect/connect couplings for bunkering liquefied natural gas

1 Scope

This document specifies the design, minimum safety, functional and marking requirements, as well as the interface types and dimensions and testing procedures for dry-disconnect/connect couplings for LNG hose bunkering systems intended for use on LNG bunkering ships, tank trucks and shore-based facilities and other bunkering infrastructures. It is not applicable to hydraulically operated quick connect/disconnect couplers (QCDC) used for hard loading arms, which is covered in ISO 16904.

Based on the technology used in industrial manufacturing at the time of development of this document, it is applicable to sizes of couplings ranging from DN 25 to DN 200.

2 Normative references

The following documents are referred to in the text in such a way that some or all of their content constitutes requirements of this document. For dated references, only the edition cited applies. For undated references, the latest edition of the referenced document (including any amendment) applies.

ISO 3834 (all parts), *Quality requirements for fusion welding of metallic materials*

ISO 5208:2015, *Industrial valves — Pressure testing of metallic valves*

EN 1092-1, *Flanges and their joints* <https://standards.iteh.ai/catalog/standards/sist/534a6d04-60fb-4c89-aca8-199136e76a9b/iso-21593-2019>

EN 12266-1:2012, *Industrial valves — Testing of metallic valves — Part 1: Pressure tests, test procedures and acceptance criteria — Mandatory requirements*

ASME B16.5-2009, *Pipe flanges and flanged fittings*

ASME B31.3-2018, *Process piping*

3 Terms and definitions

For the purposes of this document, the following terms and definitions apply.

ISO and IEC maintain terminological databases for use in standardization at the following addresses:

- ISO Online browsing platform: available at <https://www.iso.org/obp>
- IEC Electropedia: available at <http://www.electropedia.org/>

3.1

bunkering

operation of transferring LNG fuel to a vessel

[SOURCE: ISO 20519:2017, 3.1, modified — Note 1 to entry has been deleted.]

3.2

dry-disconnect

method that reduces LNG or natural gas releases into the atmosphere under normal operation to a negligible amount consistent with safety, either by equipment design or procedural practice

[SOURCE: ISO 20519:2017, 3.6]

3.3

dry-disconnect/connect coupling coupling

dry disconnect coupling

dry break coupling

mechanical device, consisting of a *nozzle* (3.4) and a *receptacle* (3.5), which permits quick connection and disconnection of a hose bunkering system of the bunker facility to the manifold of the receiving vessel, in a safe manner, without employing bolts

3.4

nozzle

half part of the *dry-disconnect/connect coupling* (3.3) typically mounted on the hose bunkering system of the bunker facility, which permits a quick connection and disconnection to the receiving vessel in a safe manner

Note 1 to entry: It includes an internal valve to seal the nozzle/bunkering system when disconnected and is opened after connection by manual operation.

Note 2 to entry: See 4.2.4.

iTeh STANDARD PREVIEW
(standards.iteh.ai)

3.5

receptacle

half part of the *dry-disconnect/connect coupling* (3.3), which is typically mounted to the manifold flange of the receiving vessel, which permits a quick connection and disconnection of the hose bunkering system in a safe manner

ISO 21593:2019
<https://standards.iteh.ai/catalog/standards/sist/534a6d04-60fb-4c89-aca8-199136e76a9b/iso-21593-2019>

Note 1 to entry: It includes an internal valve to seal the receptacle/*manifold* (3.7) system when disconnected and is opened after connection by manual operation of the *nozzle* (3.4).

Note 2 to entry: The receptacle shall always be equipped with a seal, as shown in [Figure 3](#).

Note 3 to entry: See 4.2.4.

3.6

dry gas

gas with moisture content such that the dew point of the gas at the required test pressure is at least 11 °C below the ambient test temperature

3.7

manifold

pipe assembly mounted on board LNG-fuelled vessel to which the flange of the *receptacle* (3.5) is connected

3.8

verification testing

series of tests to assure that each *coupling* (3.3) part (including *nozzle* (3.4) and *receptacle* (3.5)) meets all of its design specifications and requirements and that it fulfils its intended purposes

3.9

production testing

process of measuring the properties or performance of the *coupling* (3.3) and checking it and obtaining an indication of well productivity before being delivered from factory to customer

4 General requirements

4.1 General

The dry-disconnect/connect coupling shall be functionally compatible with the LNG bunkering system; the nozzle shall be functionally compatible with the corresponding receptacles, and vice versa.

4.2 Basic design principle

4.2.1 The coupling consists of a nozzle and a receptacle. The nozzle allows a quick connection and disconnection of the LNG bunkering system to the receptacle.

4.2.2 The poppet faces of the internal valve from the nozzle interacts and pushes the receptacle poppet toward the open position in order to allow a medium flow.

4.2.3 The nozzle and receptacle shall remain in the final position when the coupling is connected and is in fully open condition.

4.2.4 The typical structure of the two-part coupling is shown in [Figure 1](#) and [Figure 2](#):

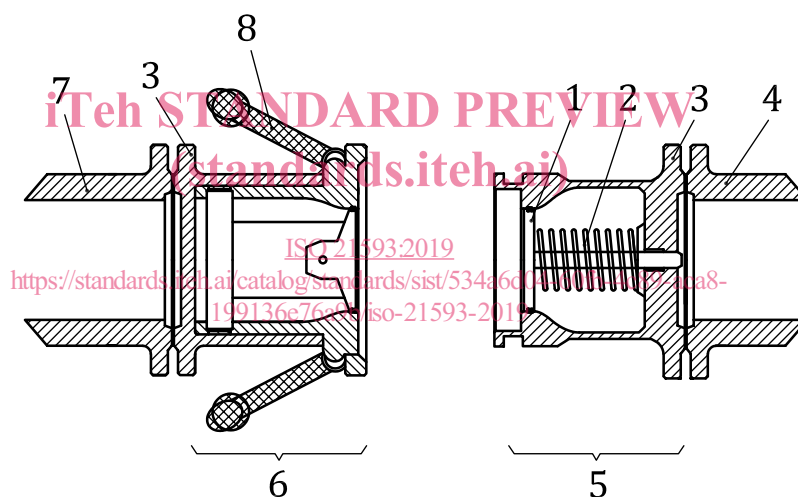

Key

- 1 internal valve
- 2 poppet
- 3 flange
- 4 manifold of LNG receiving vessel
- 5 receptacle
- 6 nozzle
- 7 hose of LNG bunkering facility
- 8 handle

Figure 1 — Sketch structure of a dry-disconnect/connect coupling — Disconnected condition

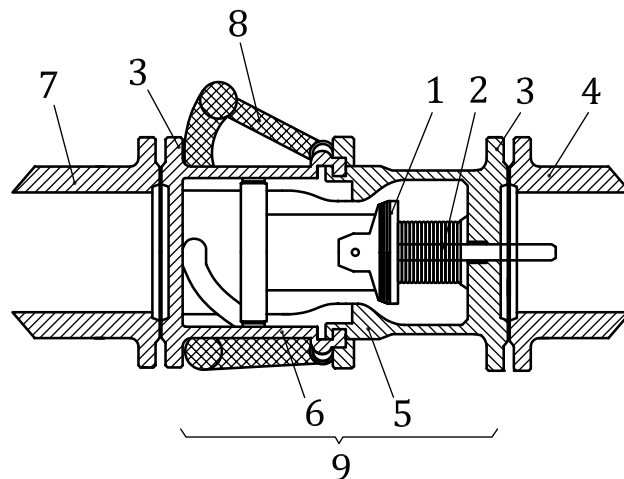

Key

- 1 internal valve
- 2 poppet
- 3 flange
- 4 manifold of LNG receiving vessel
- 5 receptacle
- 6 nozzle
- 7 hose of LNG bunkering facility
- 8 handle
- 9 coupling

ITeh STANDARD PREVIEW
(standards.iteh.ai)

Figure 2 — Sketch structure of a dry-disconnect/connect coupling — Connected condition

4.2.5 The dry disconnect/connect coupling shall be designed according to a design standard for pressure-containing equipment. Accepted design codes are:

- ASTM Boiler and Pressure Vessel Code;
- European Pressure Equipment Directive 2014/68/EU;
- EN 12516 Industrial Valves – Shell design strength;
- ISO 16904:2016, 7.2 Design of QCDC; Section 7.3 QCDC system; 9.3.8 QCDC (Testing requirements).

Other design codes can be accepted if they provide the same level of safety with respect to pressure containment.

The wall thickness of the coupling shall take into account, as a minimum but not limited to, the internal pressure, the external loads and the moments.

4.2.6 The receptacle shall always be equipped with a seal, as shown in [Figure 3](#).

4.3 Design parameters

The design pressure and temperature of the dry-disconnect/connect coupling shall comply with:

- a) Minimum design pressure:
1,6 MPa.

b) Design temperature:

-196 °C to + 85 °C.

4.4 Functional requirements

4.4.1 An interlock function shall be included to ensure the coupling is sealed first under connection, before the internal valves are opened. When disconnecting, the internal valves shall be closed first, before it is possible to disconnect the coupling. This may be achieved by an internal interlock device (two-step action) or sequential in one single rotating manoeuvre (single-step action).

4.4.2 The volume between the two internal valves shall be as small as practical and reported by the manufacturer.

4.4.3 Once connected, the coupling shall remain liquid and gas tight under all operating conditions, and shall sustain:

1. The external loads applied at the connection between the bunkering system and the ship's manifold (dynamic and static as well as ice accretion).
2. The internal loads due to the LNG transfer process, either pressure or thermal loads during transient and permanent phases.

The bending loads shall comply with the value specified in [Table 5](#).

4.4.4 It shall be possible to disconnect the nozzle from the receptacle under the maximum manifold loads, including an ice build-up on the device with a thickness of:

1. for DN 25 to DN 80: 10 mm solid ice ($d = 800 \text{ kg/m}^3$);
2. for DN 100 to DN 200: 25 mm solid ice ($d = 800 \text{ kg/m}^3$).

4.4.5 The design of the coupling shall allow the coupling to be manually connected and disconnected unaided and the maximum force to (dis)connect the nozzle from the receptacle shall not exceed 350 N. Where this force exceeds 350 N, actuation shall be pneumatically or hydraulically assisted.

The nozzle shall be so designed as to be operated without the use of tools (e.g. extension bars) and excessive force for connecting and disconnecting.

4.4.6 The operation direction to open and close shall be indicated with an indelible mark. Connected condition shall be made with a positive indication that the mechanism action is fully made.

4.4.7 The design of the nozzle and receptacle shall allow for the removal of liquid and vapour before disconnection, avoiding vapour and liquid trapped in the dead space during purging operation.

4.4.8 The nozzle shall have an integrated swivel function. It shall allow free rotation, to prevent the application of torsional loads on the bunkering system.

4.4.9 The coupling shall have suitable fire resistance properties and shall be fire type tested in accordance with recognized standards (e.g. ISO 10497).

4.4.10 The coupling shall be made of conductive, non-sparking material.

4.5 Internal valve

The backwards force of the receptacle poppet in fully open position shall be maximum of 460 N.

4.6 Protective cap/plug

A cap/plug or equivalent design feature shall be provided to prevent dust, moisture, and other foreign debris from entering the nozzle and receptacle. The cap/plug shall not allow the build-up of pressure between the receptacle and the cap as well as between the nozzle and the plug.

4.7 Handle

A handle is to be fitted to the nozzle to protect the operator from cold injuries.

5 Materials

5.1 General

The material shall be suitable for the use with LNG and for the test conditions with liquid nitrogen down to $-196\text{ }^{\circ}\text{C}$. Recommendations are mentioned in ISO 16903:2015, Table 3.

5.2 Body of coupling

5.2.1 The coupling shall be made from forged stainless steel ASTM A182 grade F316 or equivalent, in the solution heat-treated condition.

5.2.2 The coupling may be manufactured from bar material according to ASTM A479, EN 10272 or equivalent, in a solution heat-treated condition.

5.3 Bolting

Bolting shall be in accordance with ASME/ANSI B16.5 or EN 1092-1

5.4 Spring

Any springs used within the receptacle or nozzle shall be suitable for the design pressure and temperature specified in 4.3, and shall be suitable against fatigue for 10 000 cycles that is the same as the endurance test of 8.16.

5.5 Seals

Seals shall be suitable for the design pressure and temperature specified in 4.3.

5.6 Welding

Welds to stainless steel grade 316 (L) shall be made using welding procedures qualified by impact testing at $-196\text{ }^{\circ}\text{C}$ in accordance with the requirements of ASME B31.3-2018, 323.2.2 or ISO 3834 (all parts) or equivalent. Material certificates of these welded fittings shall refer to these WPs.

6 Interface types and dimensions

6.1 The end termination of the receptacle connecting to the manifold system shall be flanged in accordance with 6.3.

6.2 The end termination of the nozzle connecting to the LNG hose bunkering system shall be flanged but may be screwed by NPT or JIC below DN 150 in accordance with ASME 1.20.1 or SAE J514.

6.3 The flange shall have a raised face 'RF' in accordance with ASME/ANSI B16.5 or EN 1092-1, forged integral with the body, or attached by qualified full penetration butt-welding or inertia welding, followed by heat treatment as required by the material specification.

6.4 The receptacle shall comply with the dimensions as shown in [Figure 3](#) and [Table 1](#).

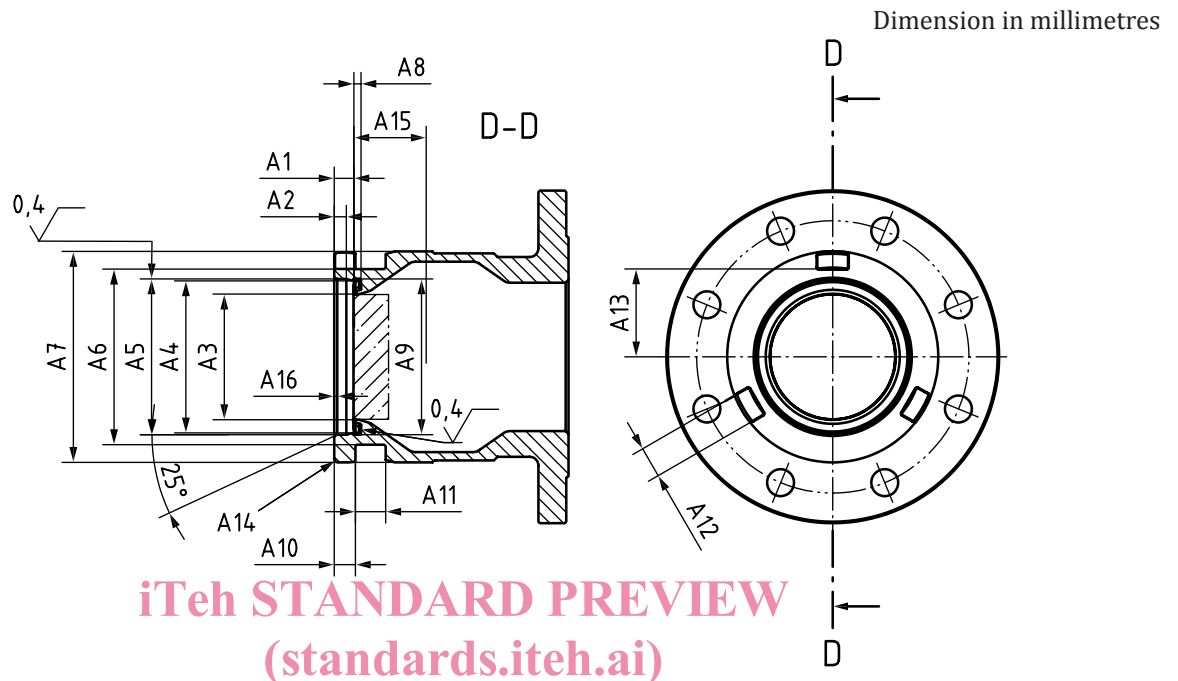

Figure 3 — Interface type and dimensions of the receptacle

<https://standards.iteh.ai/catalog/standards/sist/534a6d04-60fb-4c89-aca8-199136e76a9b/iso-21593-2019>