



Designation: D4814 – 09b

Standard Specification for Automotive Spark-Ignition Engine Fuel¹

This standard is issued under the fixed designation D4814; the number immediately following the designation indicates the year of original adoption or, in the case of revision, the year of last revision. A number in parentheses indicates the year of last reapproval. A superscript epsilon (ϵ) indicates an editorial change since the last revision or reapproval.

This standard has been approved for use by agencies of the Department of Defense.

1. Scope*

1.1 This specification covers the establishment of requirements of automotive fuels for ground vehicles equipped with spark-ignition engines.

1.2 This specification describes various characteristics of automotive fuels for use over a wide range of operating conditions. It provides for a variation of the volatility and water tolerance of automotive fuel in accordance with seasonal climatic changes at the locality where the fuel is used. For the period May 1 through Sept. 15, the maximum vapor pressure limits issued by the U.S. Environmental Protection Agency (EPA) are specified for each geographical area except Alaska and Hawaii. Variation of the antiknock index with seasonal climatic changes and altitude is discussed in [Appendix X1](#). This specification neither necessarily includes all types of fuels that are satisfactory for automotive vehicles, nor necessarily excludes fuels that can perform unsatisfactorily under certain operating conditions or in certain equipment. The significance of each of the properties of this specification is shown in [Appendix X1](#).

1.3 The spark-ignition engine fuels covered in this specification are gasoline and its blends with oxygenates, such as alcohols and ethers. This specification does not apply to fuels that contain an oxygenate as the primary component, such as Fuel Methanol (M85). The concentrations and types of oxygenates are not specifically limited in this specification. However, depending on oxygenate type, as oxygenate content increases above some threshold level, the likelihood for vehicle problems also increases. The composition of both unleaded and leaded fuel is limited by economic, legal, and technical consideration, but their properties, including volatility, are defined by this specification. In addition, the composition of unleaded fuel is subject to the rules, regulations, and Clean Air Act waivers of the U.S. Environmental Protection Agency (EPA). With regard to fuel properties, including volatility, this specification can be more or less restrictive than the EPA rules,

regulations, and waivers. Refer to [Appendix X3](#) for discussions of EPA rules relating to fuel volatility, lead and phosphorous contents, deposit control additive certification, and use of oxygenates in blends with unleaded gasoline. Contact the EPA for the latest versions of the rules and additional requirements.

1.4 This specification does not address the emission characteristics of reformulated spark-ignition engine fuel. Reformulated spark-ignition engine fuel is required in some areas to lower emissions from automotive vehicles, and its characteristics are described in the research report on reformulated spark-ignition engine fuel.² However, in addition to the legal requirements found in this research report, reformulated spark-ignition engine fuel should meet the performance requirements found in this specification.

1.5 This specification represents a description of automotive fuel as of the date of publication. The specification is under continuous review, which can result in revisions based on changes in fuel, automotive requirements, or test methods, or a combination thereof. All users of this specification, therefore, should refer to the latest edition.

NOTE 1—If there is any doubt as to the latest edition of Specification D4814, contact ASTM International Headquarters.

1.6 Tests applicable to gasoline are not necessarily applicable to its blends with oxygenates. Consequently, the type of fuel under consideration must first be identified in order to select applicable tests. Test Method [D4815](#) provides a procedure for determining oxygenate concentration in mass percent. Test Method [D4815](#) also includes procedures for calculating mass oxygen content and oxygenate concentration in volume percent. [Appendix X4](#) provides a procedure for calculating the mass oxygen content of a fuel using measured oxygenate type, oxygenate concentration in volume percent, and measured density or relative density of the fuel.

1.7 The following applies to all specified limits in this standard: For purposes of determining conformance with these specifications, an observed value or a calculated value shall be rounded “to the nearest unit” in the right-most significant digit used in expressing the specification limit, in accordance with the rounding method of Practice [E29](#). For a specification limit

¹ This specification is under the jurisdiction of ASTM Committee [D02](#) on Petroleum Products and Lubricants and is the direct responsibility of Subcommittee [D02.A0.01](#) on Gasoline and Gasoline-Oxygenate Blends.

Current edition approved Sept. 1, 2009. Published September 2009. Originally approved in 1988. Last previous edition approved in 2009 as D4814-09a. DOI: 10.1520/D4814-09B.

² Supporting data have been filed at ASTM International Headquarters and may be obtained by requesting Research Report RR: D02-1347.

*A Summary of Changes section appears at the end of this standard.

TABLE 1 Vapor Pressure and Distillation Class Requirements^A

Vapor Pressure/ Distillation Class	Vapor Pressure, ^B max, kPa (psi)	Distillation Temperatures, °C (°F), at % Evaporated. max ^C				Distillation Residue, volume %, max	Driveability Index, ^D max, °C (°F) Derived ^{E,F}	
		10 volume %, max	50 volume %		90 volume %, max			
			min ^G	max				End Point, max
AA	54(7.8)	70.(158)	77(170.)	121(250.)	190.(374)	225(437)	2	597(1250.)
A	62(9.0)	70.(158)	77(170.)	121(250.)	190.(374)	225(437)	2	597(1250.)
B	69(10.0)	65(149)	77(170.)	118(245)	190.(374)	225(437)	2	591(1240.)
C	79(11.5)	60.(140.)	77(170.)	116(240.)	185(365)	225(437)	2	586(1230.)
D	93(13.5)	55(131)	77(170.) ^H	113(235)	185(365)	225(437)	2	580.(1220.)
E	103(15.0)	50.(122)	77(170.) ^H	110.(230.)	185(365)	225(437)	2	569(1200.)

^A See 1.7 for determining conformance with specification limits in this table. When using this table to determine the conformance of gasoline volatility, the reader is advised to review other possible requirements (for example, EPA Substantially Similar rule, California Air Resources Board (CARB), Clean Burning Gasoline (CBG), other state or local and pipeline specifications).

^B Consult EPA for approved test methods for compliance with EPA vapor pressure regulations.

^C At 101.3 kPa pressure (760 mm Hg).

^D Driveability Index (DI) = 1.5 T₁₀ + 3.0 T₅₀ + 1.0 T₉₀ + 1.33°C (2.4°F) × Ethanol Volume %, where T₁₀ = distillation temperature, °C (°F), at 10 % evaporated, T₅₀ = distillation temperature, °C (°F), at 50 % evaporated, T₉₀ = distillation temperature, °C (°F), at 90 % evaporated, and 1.33 is the coefficient for the volume % ethanol present when the distillation results are determined in degrees Celsius and 2.4 is the coefficient when distillation results are determined in degrees Fahrenheit.

^E The DI specification limits are applicable at the refinery or import facility as defined by 40 CFR Part 80.2 and are not subject to correction for precision of the test method.

^F Since DI is an index and has no units, the standard temperature conversion from U.S. customary to SI units is not appropriate. The following equation is to be used to make the conversion: $DI_C = (DI_F - 176)/1.8$

^G Gasolines that may be blended with 1 to 10 volume percent ethanol or all other gasolines whose disposition with ethanol blending is not known shall meet a minimum 50 % evaporated distillation temperature of 77°C (170.°F) prior to blending with ethanol. Gasolines that contain 1 to 10 volume percent ethanol shall meet a minimum 50 % evaporated distillation temperature of 66°C (150.°F) after blending.

^H Gasolines known from the origin to retail that will not be blended with ethanol may meet a minimum 50 % evaporated distillation temperature of 66°C (150.°F) for volatility classes D and E only. Gasolines meeting these limits are not suitable for blending with ethanol.

expressed as an integer, a trailing zero is significant only if the decimal point is specified. For a specified limit expressed as an integer, and the right-most digit is non-zero, the right-most digit is significant without a decimal point being specified. This convention applies to specified limits in Tables 1, 3, and Table X8.1, and it will not be observed in the remainder of this specification.

1.8 The values stated in SI units are the standard, except when other units are specified by federal regulation. Values given in parentheses are provided for information only.

NOTE 2—Many of the values shown in Table 1 were originally developed using U.S. customary units and were subsequently soft-converted to SI values. As a result, conversion of the SI values will sometimes differ slightly from the U.S. customary values shown because of round-off. In some cases, federal regulations specify non-SI units.

1.9 The following safety hazard caveat pertains only to the test method portion, Annex A1, of this specification. *This standard does not purport to address all of the safety concerns, if any, associated with its use. It is the responsibility of the user of this standard to establish appropriate safety and health practices and determine the applicability of regulatory limitations prior to use.*

2. Referenced Documents

2.1 ASTM Standards:³

- D86 Test Method for Distillation of Petroleum Products at Atmospheric Pressure
- D130 Test Method for Corrosiveness to Copper from Petroleum Products by Copper Strip Test

- D287 Test Method for API Gravity of Crude Petroleum and Petroleum Products (Hydrometer Method)
- D381 Test Method for Gum Content in Fuels by Jet Evaporation
- D439 Specification for Automotive Gasoline⁴
- D525 Test Method for Oxidation Stability of Gasoline (Induction Period Method)
- D1266 Test Method for Sulfur in Petroleum Products (Lamp Method)
- D1298 Test Method for Density, Relative Density (Specific Gravity), or API Gravity of Crude Petroleum and Liquid Petroleum Products by Hydrometer Method
- D2622 Test Method for Sulfur in Petroleum Products by Wavelength Dispersive X-ray Fluorescence Spectrometry
- D2699 Test Method for Research Octane Number of Spark-Ignition Engine Fuel
- D2700 Test Method for Motor Octane Number of Spark-Ignition Engine Fuel
- D2885 Test Method for Determination of Octane Number of Spark-Ignition Engine Fuels by On-Line Direct Comparison Technique
- D3120 Test Method for Trace Quantities of Sulfur in Light Liquid Petroleum Hydrocarbons by Oxidative Microcoulometry
- D3231 Test Method for Phosphorus in Gasoline
- D3237 Test Method for Lead in Gasoline by Atomic Absorption Spectroscopy
- D3341 Test Method for Lead in Gasoline—Iodine Monochloride Method
- D4052 Test Method for Density, Relative Density, and API Gravity of Liquids by Digital Density Meter

³ For referenced ASTM standards, visit the ASTM website, www.astm.org, or contact ASTM Customer Service at service@astm.org. For Annual Book of ASTM Standards volume information, refer to the standard's Document Summary page on the ASTM website.

⁴ Withdrawn. The last approved version of this historical standard is referenced on www.astm.org.

- D4057 Practice for Manual Sampling of Petroleum and Petroleum Products
- D4177 Practice for Automatic Sampling of Petroleum and Petroleum Products
- D4306 Practice for Aviation Fuel Sample Containers for Tests Affected by Trace Contamination
- D4815 Test Method for Determination of MTBE, ETBE, TAME, DIPE, tertiary-Amyl Alcohol and C₁ to C₄ Alcohols in Gasoline by Gas Chromatography
- D4953 Test Method for Vapor Pressure of Gasoline and Gasoline-Oxygenate Blends (Dry Method)
- D5059 Test Methods for Lead in Gasoline by X-Ray Spectroscopy
- D5188 Test Method for Vapor-Liquid Ratio Temperature Determination of Fuels (Evacuated Chamber Method)
- D5190 Test Method for Vapor Pressure of Petroleum Products (Automatic Method)
- D5191 Test Method for Vapor Pressure of Petroleum Products (Mini Method)
- D5453 Test Method for Determination of Total Sulfur in Light Hydrocarbons, Spark Ignition Engine Fuel, Diesel Engine Fuel, and Engine Oil by Ultraviolet Fluorescence
- D5482 Test Method for Vapor Pressure of Petroleum Products (Mini Method—Atmospheric)
- D5500 Test Method for Vehicle Evaluation of Unleaded Automotive Spark-Ignition Engine Fuel for Intake Valve Deposit Formation
- D5598 Test Method for Evaluating Unleaded Automotive Spark-Ignition Engine Fuel for Electronic Port Fuel Injector Fouling
- D5599 Test Method for Determination of Oxygenates in Gasoline by Gas Chromatography and Oxygen Selective Flame Ionization Detection
- D5842 Practice for Sampling and Handling of Fuels for Volatility Measurement
- D5845 Test Method for Determination of MTBE, ETBE, TAME, DIPE, Methanol, Ethanol and *tert*-Butanol in Gasoline by Infrared Spectroscopy
- D5854 Practice for Mixing and Handling of Liquid Samples of Petroleum and Petroleum Products
- D6378 Test Method for Determination of Vapor Pressure (VP_x) of Petroleum Products, Hydrocarbons, and Hydrocarbon-Oxygenate Mixtures (Triple Expansion Method)
- D6469 Guide for Microbial Contamination in Fuels and Fuel Systems
- D6920 Test Method for Total Sulfur in Naphthas, Distillates, Reformulated Gasolines, Diesels, Biodiesels, and Motor Fuels by Oxidative Combustion and Electrochemical Detection
- D7039 Test Method for Sulfur in Gasoline and Diesel Fuel by Monochromatic Wavelength Dispersive X-ray Fluorescence Spectrometry
- E29 Practice for Using Significant Digits in Test Data to Determine Conformance with Specifications

2.2 Government Standard:

CFR 40 Code of Federal Regulations⁵

2.3 Other Standard:

CCR Title 17, §60100-§60114 California Code of Regulations⁶

3. Terminology

3.1 Definitions:

3.1.1 *antiknock index, n*—the arithmetic average of the Research octane number (RON) and Motor octane number (MON), that is, (RON + MON)/2.

3.1.2 *gasoline, n*—a volatile mixture of liquid hydrocarbons, generally containing small amounts of additives, suitable for use as a fuel in spark-ignition, internal combustion engines.

3.1.3 *gasoline-alcohol blend, n*—a fuel consisting primarily of gasoline along with a substantial amount (more than 0.35 mass % oxygen, or more than 0.15 mass % oxygen if methanol is the only oxygenate) of one or more alcohols.

3.1.4 *gasoline-ether blend, n*—a fuel consisting primarily of gasoline along with a substantial amount (more than 0.35 mass % oxygen) of one or more ethers.

3.1.5 *gasoline-oxygenate blend, n*—a fuel consisting primarily of gasoline along with a substantial amount (more than 0.35 mass % oxygen, or more than 0.15 mass % oxygen if methanol is the only oxygenate) of one or more oxygenates.

3.1.6 *oxygenate, n*—an oxygen-containing, ashless, organic compound, such as an alcohol or ether, which can be used as a fuel or fuel supplement.

3.1.7 *refinery, n*—a plant at which gasoline or diesel fuel is produced.

3.1.7.1 *Discussion*—This definition is from **CFR 40** Part 80.2. In the federal definition, a plant not only covers the conventional refinery, but also covers oxygenate blending and other facilities where gasoline is produced.

3.2 *Applicability*—To determine when a fuel contains a substantial amount of an oxygenate, a gasoline-oxygenate blend is defined as a fuel that contains more than 0.35 mass % oxygen, or more than 0.15 mass % oxygen if methanol is the only oxygenate. The definitions in this section do not apply to fuels that contain an oxygenate as the primary component; for example, fuel methanol (M85).

NOTE 3—The criteria in 3.2 were selected with consideration given to current oxygenate levels in the marketplace, state labeling practices, and consistency with federal legislation and regulations.

NOTE 4—Refer to Test Method **D4815** to calculate the mass oxygen content of a fuel using oxygenate concentration in mass %. Refer to **Appendix X4** to calculate mass oxygen content of a fuel using oxygenate concentration in volume %.

4. Ordering Information

4.1 The purchasing agency shall:

4.1.1 State the antiknock index as agreed upon with the seller,

4.1.2 Indicate the season and locality in which the fuel is to be used,

4.1.3 Indicate the lead level required (**Table 2**), and

⁵ Available from U.S. Government Printing Office, Superintendent of Documents, 732 N. Capitol St., NW, Mail Stop: SDE, Washington, DC 20401.

⁶ Available from Barclays, 50 California Street, San Francisco, CA 94111.

TABLE 2 Detailed Requirements for all Volatility Classes^A

Lead Content, max, g/L (g/U.S. gal) ^B		Copper Strip Corrosion, max	Silver Strip Corrosion, ^C max	Solvent-washed Gum Content, mg/100 mL, max	Sulfur, max, mass %		Oxidation Stability, Minimum, minutes
Unleaded	Leaded				Unleaded	Leaded	
0.013(0.05)	1.1(4.2)	No. 1	1	5	0.0080 ^D	0.15	240.

^A See [Appendix X1](#) for information on Antiknock Index.

^B See [Appendix X3](#) for U.S. EPA maximum limits for lead and phosphorus contents in unleaded gasoline ([X3.2.1](#)) and maximum average lead limits for leaded gasoline ([X3.2.2](#)).

^C See [Annex A1](#) for information regarding the test method.

^D Qualified small refineries have varying maximum sulfur limits up to 0.0450 mass % which are based on their 1997-1998 sulfur level baseline. For Geographical Phase-In Area (GPA) and qualified small refineries producing 15 ppm maximum sulfur content diesel fuel beginning in 2006, the 2006 gasoline sulfur limits are extended through 2008 for GPA refineries (0.0300 mass % cap) and through 2010 for qualified small refineries (up to 0.0450 mass % cap). If values are found in excess of 0.0080 mass %, it is the supplier's responsibility to provide proof that the source was a qualified refinery.

4.1.4 State the concentration and types of oxygenates present as agreed upon with the seller.

5. Performance Requirements

5.1 Some requirements and test methods applicable to automotive spark-ignition engine fuel depend on whether the fuel is a gasoline, or a gasoline-oxygenate blend. Test Methods [D4815](#) and [D5599](#), gas chromatographic test methods, are the recommended procedures to detect the types and amounts of oxygenates. Once the type of fuel is known, the appropriate requirements and test methods can be identified by reference to [Table 1](#), [Table 3](#), and [Section 7](#).

5.2 Volatility of fuels is varied for seasonal climatic changes and conformance to U.S. EPA volatility regulations by providing six vapor pressure/distillation classes and six vapor lock protection classes for fuel. Volatility of fuel is specified by an alphanumeric designation that uses a letter from [Table 1](#) and a number from [Table 3](#).

5.2.1 The seasonal and geographic distribution of the combined vapor pressure/distillation-vapor lock classes is shown in [Table 4](#). [Tables 5-7](#) show the federal ozone nonattainment areas at several vapor lock protection levels that require reduced vapor pressure in the summertime. [Tables 8-11](#) show at several vapor lock protection levels the areas that require federal reformulated spark-ignition engine fuel in the summertime. [Table 12](#) shows the areas with restrictive local vapor pressure limits that have been approved under the EPA state implementation plan (SIP).

5.2.2 The EPA vapor pressure regulations can cause the distillation of the fuel to be less volatile, which for some vehicles, results in a worse warm-up driveability performance.

5.2.3 Driveability Index (DI) is intended to provide control of distillation parameters and ethanol content that influence cold start and warm-up driveability. It is a function of the 10 %, 50 %, and 90 % evaporated distillation temperatures measured by Test Method [D86](#) and the ethanol content measured by the test methods shown in [7.1.9](#).

5.2.4 Test Method [D5188](#) is the method for determining vapor-liquid ratio temperatures by an evacuated chamber method for gasoline-oxygenate blends, as well as for gasoline. The methods for estimating temperature-V/L (see [Appendix X2](#)) are applicable for gasoline and gasoline-ethanol blends (1 to 10 volume %), but not for gasoline-ether blends.

5.3 Antiknock index (AKI) is very important to engine performance. The matching of engine octane requirement to fuel octane level (AKI) is critical to the durability and performance of engines; this cannot be accomplished with a

TABLE 3 Vapor Lock Protection Class Requirements^A

Vapor Lock Protection Class	Temperature, °C (°F) for a Vapor-Liquid Ratio of 20, min ^{B,C}	Special Requirements for Area V of D4814 Temperature, °C (°F) for a Vapor-Liquid Ratio of 20, min
1	54 (129)	60. (140.)
2	50. (122)	56 (133)
3	47 (116)	51 (124)
4	47 (116)	47 (116)
5	41 (105)	41 (105)
6	35 (95)	35 (95)

^A See [1.7](#) for determining conformance with numerical specification limits in this table. When using this table to determine the conformance of the temperature for a vapor-liquid ratio of 20, the reader is advised to review other applicable federal and state requirements (for example, EPA's "Substantially Similar" rule, CARB regulations, and other state and local regulations).

^B Gasoline, or blend of oxygenate and gasoline as sold to the consumer, shall meet these limits. Certain gasolines meeting the limits in Column 2 of this table may not be suitable for blending with ethanol.

^C Gasolines and gasoline-oxygenate blends sold at retail sites located in Area V shown in [Fig. X1.2](#) (generally high elevations) shall use the special limits shown in Column 3 of this table, regardless of ethanol content.

single specified minimum level of antiknock index. [Appendix X1](#) includes a discussion of antiknock indexes of fuels currently marketed and relates these levels to the octane needs of broad groups of engines and vehicles. Also discussed is the effect of altitude and weather on vehicle antiknock requirements.

5.4 Additional fuel requirements are shown in [Table 2](#).

5.5 The properties of gasoline-oxygenate blends can differ considerably from those of gasoline. Consequently, additional requirements are needed for gasoline-oxygenate blends. These requirements involve evaluation of compatibility with plastic and elastomeric materials in fuel systems, corrosion of metals, and especially in the case of gasoline-alcohol blends, water tolerance. Requirements for metal corrosion (other than copper) and material compatibility are not given because test methods and appropriate limits are still under development. When these have been developed, they will be included in this specification.

5.6 Depending on oxygenate type and concentration in the blend, vehicle driveability with gasoline-oxygenate blends can differ significantly from that with gasolines having similar volatility characteristics.

5.7 Water Tolerance:

5.7.1 The term water tolerance is used to indicate the ability of a gasoline-oxygenate blend to dissolve water without phase separation. This may not be a problem with gasoline-ether blends, but it is of primary concern for alcohol-containing

TABLE 4 Schedule of Seasonal and Geographical Volatility Classes^A

NOTE 1—This schedule, subject to agreement between purchaser and seller, denotes the volatility properties of the fuel at the time and place of bulk delivery to the fuel dispensing facilities for the end user. For Sept. 16 through April 30 (the time period not covered by EPA Phase II vapor pressure requirements), volatility properties for the previous month or the current month are acceptable for the end user from the 1st through the 15th day of the month. From the 16th day through the end of the month, volatility properties of the fuel delivered to the end user shall meet the requirements of the specified class(es). To ensure compliance with EPA Phase II vapor pressure requirements, vapor pressure for finished gasoline tankage at refineries, importers, pipelines, and terminals during May and for the entire distribution system, including retail stations, from June 1 to Sept. 15 shall meet only the current month's class. Shipments should anticipate this schedule.

NOTE 2—Where alternative classes are listed, either class or intermediate classes are acceptable; the option shall be exercised by the seller.

NOTE 3—See Appendix X2 of Research Report: D02-1347² for detailed description of areas. Contact EPA for the latest information on areas requiring reformulated fuel.

State	Jan.	Feb.	Mar.	Apr.	May ^B	June	July	Aug.	Sept. 1–15	Sept. 16–30	Oct.	Nov.	Dec.
Alabama	D-4	D-4	D-4/C-3	C-3/A-3	A-3 (C-3)	A-3 ^C	A-3 ^C	A-2 ^D	A-2 ^D	A-2/C-3	C-3	C-3/D-4	D-4
Alaska	E-6	E-6	E-6	E-6	E-6/D-4	D-4	D-4	D-4	D-4	D-4/E-6	E-6	E-6	E-6
Arizona: ^E													
N 34° Latitude and E111° Longitude	D-4	D-4	D-4/C-3	C-3/A-2	A-2 (B-2)	A-1	A-1	A-1	A-2	A-2/B-2	B-2/C-3	C-3/D-4	D-4
Remainder of State	D-4	D-4/C-3	C-3/B-2	B-2/A-2	A-2 (B-2)	A-1 ^F	A-1 ^F	A-1 ^F	A-1 ^D	A-1	A-1/B-2	B-2/C-3	C-3/D-4
Arkansas	E-5/D-4	D-4	D-4/C-3	C-3/A-3	A-3 (C-3)	A-3	A-2	A-2	A-2	A-2/C-3	C-3/D-4	D-4	D-4/E-5
California: ^{E,G}													
North Coast	E-5/D-4	D-4	D-4	D-4/A-3	A-3 (C-3)	A-3 ^C	A-2 ^D	A-2 ^D	A-2 ^D	A-2/B-2	B-2/C-3	C-3/D-4	D-4/E-5
South Coast	D-4	D-4	D-4/C-3	C-3/A-3	A-3 (C-3)	A-2 ^{D,H}	A-2 ^{D,H}	A-2 ^{D,H}	A-2 ^{D,H}	A-2/B-2	B-2/C-3	C-3/D-4	D-4
Southeast	D-4	D-4/C-3	C-3/B-2	B-2/A-2	A-2 (B-2)	A-1 ^F	A-1 ^{F,I}	A-1 ^{F,I}	A-1 ^{F,I}	A-1	A-1/B-2	B-2/C-3	C-3/D-4
Interior	E-5/D-4	D-4	D-4	D-4/A-3	A-3 (C-3)	A-2 ^{D,H}	A-2 ^{D,H}	A-2 ^{D,H}	A-2 ^{D,H}	A-2/B-2	B-2/C-3	C-3/D-4	D-4/E-5
Colorado	E-5	E-5/D-4	D-4/C-3	C-3/A-3	A-3 (C-3)	A-2 ^D	A-2 ^D	A-2 ^D	A-2 ^D	A-2/B-2	B-2/C-3	C-3/D-4	D-4/E-5
Connecticut	E-5	E-5	E-5/D-4	D-4/A-4	A-4 (D-4)	A-3 ^J	A-3 ^J	A-3 ^J	A-3 ^J	A-3/D-4	D-4	D-4/E-5	E-5
Delaware	E-5	E-5	E-5/D-4	D-4/A-4	A-4 (D-4)	A-3 ^J	A-3 ^J	A-3 ^J	A-3 ^J	A-3/C-3	C-3/D-4	D-4/E-5	E-5
District of Columbia	E-5	E-5/D-4	D-4	D-4/A-3	A-3 (C-3)	A-3 ^K	A-3 ^K	A-3 ^K	A-3 ^K	A-3/C-3	C-3/D-4	D-4/E-5	E-5
Florida	D-4	D-4	D-4/C-3	C-3/A-3	A-3 (C-3)	A-3 ^C	A-3 ^C	A-3 ^C	A-3 ^C	A-3/C-3	C-3	C-3/D-4	D-4
Georgia: ^E	D-4	D-4	D-4/C-3	C-3/A-3	A-3 (C-3)	A-3 ^C	A-3 ^C	A-2 ^D	A-2 ^D	A-2/C-3	C-3	C-3/D-4	D-4
Hawaii	C-3	C-3	C-3	C-3	C-3	C-3	C-3	C-3	C-3	C-3	C-3	C-3	C-3
I Idaho: ^E													
N 46° Latitude	E-5	E-5	E-5/D-4	D-4/A-4	A-4 (D-4)	A-3	A-2	A-2	A-2	A-2/C-3	C-3/D-4	D-4/E-5	E-5
S 46° Latitude	E-5	E-5/D-4	D-4	D-4/A-3	A-3 (C-3)	A-2	A-2	A-2	A-2	A-2/B-2	B-2/C-3	C-3/D-4	D-4/E-5
Illinois: ^E													
N 40° Latitude	E-5	E-5	E-5/D-4	D-4/A-4	A-4 (D-4)	A-3 ^J	A-3 ^J	A-3 ^J	A-3 ^J	A-3/C-3	C-3/D-4	D-4/E-5	E-5
S 40° Latitude	E-5	E-5	E-5/D-4	D-4/A-3	A-3 (C-3)	A-3	A-3	A-3	A-3	A-3/C-3	C-3/D-4	D-4	D-4/E-5
Indiana: ^E	E-5	E-5	E-5/D-4	D-4/A-4	A-4 (D-4)	A-3 ^J	A-3 ^J	A-3 ^J	A-3 ^J	A-3/C-3	C-3/D-4	D-4/E-5	E-5
Iowa	E-5	E-5	E-5/D-4	D-4/A-3	A-3 (C-3)	A-3	A-3	A-3	A-3	A-3/C-3	C-3/D-4	D-4/E-5	E-5
Kansas: ^E	E-5	E-5/D-4	D-4/C-3	C-3/A-3	A-3 (C-3)	A-2 ^D	A-2 ^D	A-2 ^D	A-2 ^D	A-2/B-2	B-2/C-3	C-3/D-4	D-4/E-5
Kentucky	E-5	E-5/D-4	D-4	D-4/A-3	A-3 (C-3)	A-3 ^J	A-3 ^J	A-3 ^J	A-3 ^J	A-3/C-3	C-3/D-4	D-4/E-5	E-5
Louisiana	D-4	D-4	D-4/C-3	C-3/A-3	A-3 (C-3)	A-3 ^C	A-3 ^C	A-2 ^D	A-2 ^D	A-2/C-3	C-3	C-3/D-4	D-4
Maine: ^E	E-5	E-5	E-5/D-4	D-4/A-4	A-4 (D-4)	A-3	A-3	A-3	A-3	A-3/D-4	D-4	D-4/E-5	E-5
Maryland	E-5	E-5	E-5/D-4	D-4/A-4	A-4 (D-4)	A-3 ^{J,K}	A-3 ^{J,K}	A-3 ^{J,K}	A-3 ^{J,K}	A-3/C-3	C-3/D-4	D-4/E-5	E-5
Massachusetts	E-5	E-5	E-5/D-4	D-4/A-4	A-4 (D-4)	A-3 ^J	A-3 ^J	A-3 ^J	A-3 ^J	A-3/D-4	D-4	D-4/E-5	E-5
Michigan: ^E	E-5	E-5	E-5/D-4	D-4/A-4	A-4 (D-4)	A-3	A-3	A-3	A-3	A-3/D-4	D-4	D-4/E-5	E-5
Minnesota	E-5	E-5	E-5/D-4	D-4/A-4	A-4 (D-4)	A-3	A-3	A-3	A-3	A-3/C-3	C-3/D-4	D-4/E-5	E-5
Mississippi	D-4	D-4	D-4/C-3	C-3/A-3	A-3 (C-3)	A-3	A-3	A-2	A-2	A-2/C-3	C-3	C-3/D-4	D-4
Missouri: ^E	E-5	E-5/D-4	D-4	D-4/A-3	A-3 (C-3)	A-3 ^C	A-2 ^D	A-2 ^D	A-2 ^D	A-2/C-3	C-3/D-4	D-4	D-4/E-5
Montana	E-5	E-5/D-4	D-4/A-3	A-3 (C-3)	A-2	A-2	A-2	A-2	A-2	A-2/C-3	C-3/D-4	D-4/E-5	E-5
Nebraska	E-5	E-5	E-5/D-4	D-4/A-3	A-3 (C-3)	A-2	A-2	A-2	A-2	A-2/B-2	B-2/C-3	C-3/D-4	D-4/E-5
Nevada: ^E													
N 38° Latitude	E-5	E-5/D-4	D-4	D-4/A-3	A-3 (C-3)	A-2 ^D	A-2 ^D	A-2 ^D	A-2 ^D	A-2/B-2	B-2/C-3	C-3/D-4	D-4/E-5
S 38° Latitude	D-4	D-4/C-3	C-3/B-2	B-2/A-2	A-2 (B-2)	A-1	A-1	A-1	A-1	A-1	A-1/B-2	B-2/C-3	C-3/D-4
New Hampshire	E-5	E-5	E-5/D-4	D-4/A-4	A-4 (D-4)	A-3 ^J	A-3 ^J	A-3 ^J	A-3 ^J	A-3/D-4	D-4	D-4/E-5	E-5
New Jersey	E-5	E-5	E-5/D-4	D-4/A-4	A-4 (D-4)	A-3 ^J	A-3 ^J	A-3 ^J	A-3 ^J	A-3/D-4	D-4	D-4/E-5	E-5
New Mexico: ^E													
N 34° Latitude	E-5/D-4	D-4	D-4/C-3	C-3/A-2	A-2 (B-2)	A-1	A-1	A-2	A-2	A-2/B-2	B-2/C-3	C-3/D-4	D-4
S 34° Latitude	D-4	D-4/C-3	C-3/B-2	B-2/A-2	A-2 (B-2)	A-1	A-1	A-1	A-1	A-1/B-2	B-2/C-3	C-3/D-4	D-4
New York	E-5	E-5	E-5/D-4	D-4/A-4	A-4 (D-4)	A-3 ^J	A-3 ^J	A-3 ^J	A-3 ^J	A-3/D-4	D-4	D-4/E-5	E-5
North Carolina	E-5/D-4	D-4	D-4	D-4/A-3	A-3 (C-3)	A-3 ^C	A-3 ^C	A-2 ^D	A-2 ^D	A-2/C-3	C-3/D-4	D-4	D-4/E-5
North Dakota	E-5	E-5	E-5/D-4	D-4/A-4	A-4 (D-4)	A-3	A-2	A-2	A-2	A-2/C-3	C-3/D-4	D-4/E-5	E-5
Ohio: ^E	E-5	E-5	E-5/D-4	D-4/A-4	A-4 (D-4)	A-3	A-3	A-3	A-3	A-3/C-3	C-3/D-4	D-4/E-5	E-5
Oklahoma	E-5/D-4	D-4	D-4/C-3	C-3/A-3	A-3 (C-3)	A-2	A-2	A-2	A-2	A-2/B-2	B-2/C-3	C-3/D-4	D-4/E-5
Oregon: ^E													
E122° Longitude	E-5	E-5/D-4	D-4	D-4/A-4	A-4 (D-4)	A-3	A-2	A-2	A-2	A-2/C-3	C-3/D-4	D-4	D-4/E-5
W122° Longitude	E-5	E-5/D-4	D-4	D-4/A-4	A-4 (D-4)	A-3 ^C	A-3 ^C	A-3 ^C	A-3 ^C	A-3/C-3	C-3/D-4	D-4/E-5	E-5
Pennsylvania: ^E	E-5	E-5	E-5/D-4	D-4/A-4	A-4 (D-4)	A-3 ^J	A-3 ^J	A-3 ^J	A-3	A-3/D-4	D-4	D-4/E-5	E-5
Rhode Island	E-5	E-5	E-5/D-4	D-4/A-4	A-4 (D-4)	A-3 ^J	A-3 ^J	A-3 ^J	A-3	A-3/D-4	D-4	D-4/E-5	E-5
South Carolina	D-4	D-4	D-4	D-4/A-3	A-3 (C-3)	A-3	A-3	A-2	A-2	A-2/C-3	C-3/D-4	D-4	D-4
South Dakota	E-5	E-5	E-5/D-4	D-4/A-3	A-3 (C-3)	A-2	A-2	A-2	A-2	A-2/B-2	B-2/C-3	C-3/D-4	D-4/E-5
Tennessee	E-5/D-4	D-4	D-4	D-4/A-3	A-3 (C-3)	A-3 ^C	A-3 ^C	A-2 ^D	A-2 ^D	A-2/C-3	C-3/D-4	D-4	D-4/E-5
Texas: ^E													

TABLE 4 Continued

State	Jan.	Feb.	Mar.	Apr.	May ^B	June	July	Aug.	Sept. 1–15	Sept. 16–30	Oct.	Nov.	Dec.
E99° Longitude	D-4	D-4	D-4/C-3	C-3/A-3	A-3 (C-3)	A-3 ^{C,K}	A-2 ^{D,H}	A-2 ^{D,H}	A-2 ^{D,H}	A-2/B-2	B-2/C-3	C-3/D-4	D-4
W 99° Longitude	D-4	D-4/C-3	C-3/B-2	B-2/A-2	A-2 (B-2)	A-1 ^F	A-1 ^F	A-1 ^F	A-1 ^F	A-1/B-2	B-2/C-3	C-3/D-4	D-4
Utah	E-5	E-5/D-4	D-4	D-4/A-3	A-3 (C-3)	A-2 ^D	A-2 ^D	A-2 ^D	A-2 ^D	A-2/B-2	B-2/C-3	C-3/D-4	D-4/E-5
Vermont	E-5	E-5	E-5/D-4	D-4/A-4	A-4 (D-4)	A-3	A-3	A-3	A-3	A-3/D-4	D-4	D-4/E-5	E-5
Virginia	E-5	E-5/D-4	D-4	D-4/A-3	A-3 (C-3)	A-3 ^{C,K}	A-3 ^{C,K}	A-3 ^{C,K}	A-3 ^{C,K}	A-3/C-3	C-3/D-4	D-4/E-5	E-5
Washington:													
E 122° Longitude	E-5	E-5	E-5/D-4	D-4/A-4	A-4 (D-4)	A-3	A-2	A-2	A-2	A-2/C-3	C-3/D-4	D-4/E-5	E-5
W 122° Longitude	E-5	E-5	E-5/D-4	D-4/A-4	A-4 (D-4)	A-3	A-3	A-3	A-3	A-3/C-3	C-3/D-4	D-4/E-5	E-5
West Virginia	E-5	E-5	E-5/D-4	D-4/A-4	A-4 (D-4)	A-3	A-3	A-3	A-3	A-3/C-3	C-3/D-4	D-4/E-5	E-5
Wisconsin	E-5	E-5	E-5/D-4	D-4/A-4	A-4 (D-4)	A-3 ^J	A-3 ^J	A-3 ^J	A-3 ^J	A-3/C-3	C-3/D-4	D-4/E-5	E-5
Wyoming	E-5	E-5	E-5/D-4	D-4/A-3	A-3 (C-3)	A-2	A-2	A-2	A-2	A-2/B-2	B-2/C-3	C-3/D-4	D-4/E-5

^A For the period May 1 through September 15, the specified vapor pressure classes comply with 1992 U.S. EPA Phase II volatility regulations. Reformulated spark-ignition engine fuel blended to meet the requirements of the EPA "Complex Model" shall also meet the Phase II volatility regulations. EPA regulations (under the Phase II regulations) allow 1.0 psi higher vapor pressure for gasoline-ethanol blends containing 9 to 10 volume % ethanol for the same period, except for fuels blended to meet the "Complex Model" regulations. See Appendix X3 for additional federal volatility regulations.

^B Values in parentheses are permitted for retail stations and other end users.

^C See Table 5 for specific area requirements.

^D See Table 6 for specific area requirements.

^E See Table 12 for specific area requirements.

^F See Table 7 for specific area requirements.

^G Details of State Climatological Division by CARB air basin and county as indicated (Descriptions of the California Air Basins are found in the California Code of Regulations 2.3):

California, North Coast—CARB North Coast, Lake County, San Francisco Bay Area, and North Central Coast Air Basins (Alameda, Contra Costa, Del Norte, Humboldt, Lake, Marin, Mendocino, Monterey, Napa, San Benito, San Francisco, San Mateo, Santa Clara, Santa Cruz, Solano, Sonoma, and Trinity Counties and part of Solano County).

California, interior—CARB Northeast Plateau, Sacramento Valley, Mountain Counties, Lake Tahoe, and San Joaquin Valley Air Basins (Amador, Butte, Calaveras, Colusa, El Dorado, Fresno, Glenn, Kings, Lassen, Madera, Mariposa, Merced, Modoc, Nevada, Placer, Plumas, Sacramento, San Joaquin, Shasta, Sierra, Siskiyou, Stanislaus, Sutter, Tehama, Tulare, Tuolumne, Yolo, and Yuba Counties, and parts of Kern and Solano Counties).

California, South Coast—CARB South Central Coast, San Diego, and South Coast Air Basins (Los Angeles, Orange, San Diego, San Luis Obispo, Santa Barbara, and Ventura Counties, and parts of Riverside and San Bernardino Counties).

California, Southeast—CARB Great Basin Valleys, Salton Sea, and Mojave Desert Air Basins (Alpine, Imperial, Inyo, and Mono Counties, and parts of Kern, Los Angeles, Riverside, San Bernardino Counties).

^H See Table 10 for specific requirements.

^I See Table 11 for specific area requirements.

^J See Table 8 for specific area requirements.

^K See Table 9 for specific area requirements.

TABLE 5 Ozone Nonattainment Areas Requiring Volatility Class AA-3

NOTE—See 40 CFR Part 81.300 for description of the geographic boundary for each area.

Alabama ^A —Jefferson and Shelby counties
California ^A —Alameda, Contra Costa, Marin, Monterey, Napa, San Francisco, San Benito, San Mateo, Santa Clara, Santa Cruz, and Solano (part) counties
Florida—Broward, Dade, Duval, Hillsborough, Palm Beach, and Pinellas counties
Georgia ^A —Cherokee, Clayton, Cobb, Coweta, Dekalb, Douglas, Fayette, Forsyth, Fulton, Gwinnett, Henry, Paulding, and Rockdale counties
Louisiana—Ascension, Beauregard, Calcasieu, East Baton Rouge, Iberville, Jefferson, Lafayette, Lafourche, Livingston, Orleans, Point Coupee, Saint Bernard, Saint Charles, Saint James, Saint Mary, and West Baton Rouge parishes
Missouri—Franklin, Jefferson, Saint Charles, and Saint Louis counties; and the city of St. Louis
North Carolina—Davidson, Davie (part), Durham, Forsyth, Gaston, Granville (part), Guilford, Mecklenburg, and Wake counties
Oregon—Clackamas (part), Marion (part), Multnomah (part), Polk (part), and Washington (part) counties
Tennessee—Davidson, Rutherford, Shelby, Sumner, Williamson, and Wilson counties
Texas—Hardin, Jefferson, Orange, and Victoria counties
Virginia—Smyth County (part)

^A See Table 12 for local vapor pressure limits.

blends, as blends of gasoline with low-molecular weight alcohols generally will dissolve about 0.1 to 0.7 mass % of water under normal conditions, depending on the nature and amount of the alcohol(s) used, the specific hydrocarbons present, and the temperature of the blend. Additional information on water tolerance is provided in Appendix X8.

TABLE 6 Ozone Nonattainment Areas Requiring Volatility Class AA-2

NOTE—See 40 CFR Part 81.300 for description of the geographic boundary for each area.

Alabama ^A —Jefferson and Shelby counties
Arizona ^A —Maricopa County
California ^A —Alameda, Butte, Contra Costa, Fresno, Kern (part), Kings, Madera, Marin, Merced, Monterey, Napa, San Benito, San Francisco, San Joaquin, San Mateo, Santa Barbara, Santa Clara, Santa Cruz, Stanislaus, Tulare, and Yuba counties
Colorado—Adams (part), Arapahoe (part), Boulder (part), Broomfield, Denver, Douglas, and Jefferson counties
Georgia ^A —Cherokee, Clayton, Cobb, Coweta, Dekalb, Douglas, Fayette, Forsyth, Fulton, Gwinnett, Henry, Paulding, and Rockdale counties
Kansas ^A —Johnson and Wyandotte counties
Louisiana—Ascension, Beauregard, Calcasieu, East Baton Rouge, Iberville, Jefferson, Lafayette, Lafourche, Livingston, Orleans, Point Coupee, Saint Bernard, Saint Charles, Saint James, Saint Mary, and West Baton Rouge parishes
Missouri—Franklin, Jefferson, Saint Charles, and Saint Louis counties; and the city of St. Louis
Nevada—Washoe County
North Carolina—Davidson, Davie (part), Durham, Forsyth, Gaston, Granville (part), Guilford, Mecklenburg, and Wake counties
Tennessee—Davidson, Rutherford, Shelby, Sumner, Williamson, and Wilson counties
Texas—Hardin, Jefferson, Orange, and Victoria counties
Utah—Davis and Salt Lake counties

^A See Table 12 for local vapor pressure limits.

5.8 Deposit control additives are added to fuel to help keep carburetors, fuel injectors, and intake valves clean. Deposit

TABLE 7 Ozone Nonattainment Areas Requiring Volatility Class AA-1

NOTE—See 40 CFR Part 81.300 for description of the geographic boundary for each area.

Arizona^A—Maricopa County
 California^A—Imperial and Kern (part) counties
 Texas^A—El Paso County

^A See Table 12 for local vapor pressure limits.

TABLE 8 Federal RFG Areas Requiring Volatility Class A-3

NOTE 1—See 40 CFR Part 81.300 for description of the geographic boundary for each area.

NOTE 2—No waiver for gasoline-ethanol blends.

Connecticut—All counties
 Delaware—All counties
 Illinois^A—Cook, Du Page, Grundy (part), Kane, Kendall (part), Lake, McHenry, and Will counties
 Indiana^A—Lake and Porter counties
 Kentucky—Boone, Bullitt (part), Campbell, Jefferson, Kenton, and Oldham (part) counties
 Maryland—Cecil County
 Massachusetts—All counties
 New Hampshire—Hillsborough, Merrimack, Rockingham, and Strafford counties
 New Jersey—All counties
 New York—Bronx, Dutchess, Essex (part), Kings, Nassau, New York, Orange, Putnam, Queens, Richmond, Rockland, Suffolk, and Westchester counties
 Pennsylvania—Bucks, Chester, Delaware, Montgomery, and Philadelphia counties
 Rhode Island—All counties
 Wisconsin—Kenosha, Milwaukee, Ozaukee, Racine, Washington, and Waukesha counties

^A See Table 12 for local vapor pressure limits.

TABLE 9 Federal RFG Areas Requiring Volatility Class AA-3

NOTE 1—See 40 CFR Part 81.300 for description of the geographic boundary for each area.

NOTE 2—No waiver for gasoline-ethanol blends.

District of Columbia
 Maryland—Anne Arundel, Baltimore, Calvert, Carroll, Charles, Frederick, Harford, Howard, Kent, Montgomery, Prince George's, and Queen Anne's counties
 Texas—Brazoria, Chambers, Collin, Dallas, Denton, Fort Bend, Galveston, Harris, Liberty, Montgomery, Tarrant, and Waller counties
 Virginia—Arlington, Charles City, Chesterfield, Fairfax, Hanover, Henrico, James City, Loudoun, Prince William, Stafford, and York counties and independent cities of Alexandria, Chesapeake, Colonial Heights, Fairfax, Falls Church, Hampton, Hopewell, Manassas, Manassas Park, Newport News, Norfolk, Poquoson, Portsmouth, Richmond, Suffolk, Virginia Beach, and Williamsburg

TABLE 10 Federal RFG Areas Requiring Volatility Class AA-2

NOTE 1—See 40 CFR Part 81.305 for description of the geographic boundary for each area.

NOTE 2—No waiver for gasoline-ethanol blends.

California^A—El Dorado (part), Los Angeles, Orange, Placer (part), Riverside (part), Sacramento, San Bernardino (part), San Diego, Solano (part), Sutter (part), Ventura, and Yolo Counties
 Texas—Brazoria, Chambers, Collin, Dallas, Denton, Fort Bend, Galveston, Harris, Liberty, Montgomery, Tarrant, and Waller counties

^A See Table 12 for local vapor pressure limits.

control additives are required to be certified by the EPA as summarized in X3.5. Each additive is certified for use at a lowest additive concentration (LAC), which is the lowest level

TABLE 11 Federal RFG Area Requiring Volatility Class AA-1

NOTE 1—See 40 CFR Part 81.300 for description of the geographic boundary for each area.

NOTE 2—No waiver for gasoline-ethanol blends.

California^A—Los Angeles (part), Riverside (part), and San Bernardino (part) counties

^A See Table 12 for local vapor pressure limits.

TABLE 12 Federally Approved State Implementation Plan Areas Requiring More Restrictive Maximum Vapor Pressure Limits

NOTE—Some areas are awaiting official EPA approval for the more restrictive local vapor pressure limits.

Alabama—Jefferson and Shelby counties—48.2 kPa (7.0 psi) max June 1 - Sept. 15^A
 Arizona—Maricopa County, Pinal(part), and Yavapai (part)—48.2 kPa (7.0 psi) max June 1 - Sept. 30, 62.0 kPa (9.0 psi) max Oct. 1 - Mar. 31
 California—48.26 kPa (7.00 psi) max April 1, May 1, or June 1 - Sept. 30 or Oct. 31 depending on air basin
 Georgia—Banks, Barrow, Bartow, Butts, Carroll, Chatooga, Cherokee, Clarke, Clayton, Cobb, Coweta, Dawson, Dekalb, Douglas, Fayette, Floyd, Forsyth, Fulton, Gordon, Gwinnett, Hall, Haralson, Heard, Henry, Jackson, Jasper, Jones, Lamar, Lumpkin, Madison, Meriwether, Monroe, Morgan, Newton, Oconee, Paulding, Pickens, Pike, Polk, Putnam, Rockdale, Spalding, Troup, Upson, and Walton counties—48.2 kPa (7.0 psi) max June 1 - Sept 15^A
 Illinois—Madison, Monroe, and Saint Clair Counties area – 49.6 kPa (7.2 psi) max June 1 - Sept. 15^A
 Indiana—Clark and Floyd counties area – 53.8 kPa (7.8 psi) max May 1 terminal/June 1 retail - Sept. 15^A
 Kansas—Johnson and Wyandotte counties—48.2 kPa (7.0 psi) max June 1 - Sept. 15^A
 Maine—Androscooggin, Cumberland, Kennebec, Knox, Lincoln, Sagadahoc, and York Counties—53.8 kPa (7.8 psi) max May 1-Sept 15
 Michigan—Lenawee, Livingston, Macomb, Monroe, Oakland, Saint Clair, Washtenaw, and Wayne counties—48.2 kPa (7.0 psi) max June 1 - Sept 15^A
 Missouri—Clay, Jackson, and Platte counties—48.2 kPa (7.0 psi) max June 1 - Sept. 15^A
 Ohio—Butler, Clark, Clermont, Greene, Hamilton, Miami, Montgomery, and Warren counties—53.8 kPa (7.8 psi) max June 1 - Sept. 15^A
 Pennsylvania—Allegheny, Armstrong, Beaver, Butler, Fayette, Washington, and Westmoreland counties—53.8 kPa (7.8 psi) max May 1 Terminal/June 1 Retail - Sept. 15
 Texas—El Paso County—48.2 kPa (7.0 psi) max May 1 terminal/June 1 retail - Sept. 15
 Texas—Anderson, Angelina, Aransas, Atascosa, Austin, Bastrop, Bee, Bell, Bexar, Bosque, Bowie, Brazos, Burleson, Caldwell, Calhoun, Camp, Cass, Cherokee, Colorado, Comal, Cooke, Coryell, De Witt, Delta, Ellis, Falls, Fannin, Fayette, Franklin, Freestone, Goliad, Gonzales, Grayson, Gregg, Grimes, Guadalupe, Harrison, Hays, Henderson, Hill, Hood, Hopkins, Houston, Hunt, Jackson, Jasper, Johnson, Karnes, Kaufman, Lamar, Lavaca, Lee, Leon, Limestone, Live Oak, Madison, Marion, Matagorda, McLennan, Milam, Morris, Nacogdoches, Navarro, Newton, Nueces, Panola, Parker, Polk, Rains, Red River, Refugio, Robertson, Rockwall, Rusk, Sabine, San Jacinto, San Patricio, San Augustine, Shelby, Smith, Somervell, Titus, Travis, Trinity, Tyler, Upshur, VanZandt, Victoria, Walker, Washington, Wharton, Williamson, Wilson, Wise, and Wood counties—53.8 kPa (7.8 psi) max May 1 terminal/June 1 retail - October 1

^A A 1.0 psi higher vapor pressure is allowed for gasoline-ethanol blends containing 9 to 10 volume % ethanol.

certified to be effective in preventing deposit formation. All parties who blend deposit control additives into fuel must complete mandatory volume additive reconciliation (VAR) accounting to establish that the product was additized at a concentration that was at least equal to the LAC.

6. Workmanship

6.1 The finished fuel shall be visually free of undissolved water, sediment, and suspended matter; it shall be clear and bright at the ambient temperature or 21°C (70°F), whichever is higher.

6.2 Fuel to be used in this test shall not be cooled below about 15°C (59°F) or its temperature at the time the sample was taken, whichever is lower, as cooling of gasoline-oxygenate blends can produce changes in appearance that are not reversed on rewarming.

6.3 The finished fuel shall also be free of any adulterant or contaminant that may render the fuel unacceptable for its commonly used applications.

7. Test Methods

7.1 The requirements of this specification shall be determined in accordance with the methods listed below. Refer to the listed test methods to determine applicability or required modifications for use with gasoline-oxygenate blends.

7.1.1 *Distillation*—Test Method **D86**.

7.1.2 *Vapor-Liquid Ratio*—Test Method **D5188** is an evacuated chamber method for determining temperatures for vapor-liquid ratios between 8 to 1 and 75 to 1. For this specification, it is conducted at a ratio of 20 to 1. It may be used for gasoline and gasoline-oxygenate blends.

7.1.3 *Vapor Pressure*—Test Methods **D4953**, **D5190**, **D5191**, **D5482**, or **D6378**.

7.1.3.1 When using Test Method **D6378**, determine VP_4 at 37.8°C (100°F) using a sample from a 1 L container and convert to DVPE (**D5191** equivalence) using the following equation:

$$\text{Predicted DVPE} = VP_4 \text{ at } 37.8^\circ\text{C} - 1.005 \text{ kPa} (0.15 \text{ psi}) \quad (1)$$

7.1.4 *Corrosion, for Copper*—Test Method **D130**, 3 h at 50°C (122°F).

7.1.5 *Solvent-Washed Gum Content*—Test Method **D381**, air jet apparatus.

7.1.6 *Sulfur*—Test Methods **D1266**, **D2622**, **D3120**, **D5453**, **D6920**, or **D7039**. With Test Method **D3120**, fuels with sulfur content greater than 100 ppm (0.0100 mass %) must be diluted with *isooctane*. The dilution of the sample may result in a loss of precision. Test Method **D3120** cannot be used when the lead concentration is greater than 0.4 g/L (1.4 g/U.S. gal).

7.1.7 *Lead*—Test Methods **D3341** or **D5059** (Test Methods A or B). For lead levels below 0.03 g/L (0.1 g/U.S. gal), use Test Methods **D3237** or **D5059** (Test Method C).

7.1.8 *Oxidation Stability*—Test Method **D525**.

7.1.9 *Oxygenate Detection*—Test Methods **D4815**, **D5599**, or **D5845**. These test methods are designed for the quantitative determination of methyl *tert*-butyl ether (MTBE), ethyl *tert*-butyl ether (ETBE), *tert*-amyl methyl ether (TAME), diisopropyl ether (DIPE), methyl alcohol, ethyl alcohol, and *tert*-butyl alcohol. In addition, Test Methods **D4815** and **D5599** are designed for the quantitative determination of *n*-propyl alcohol, *isopropyl* alcohol, *n*-butyl alcohol, *sec*-butyl alcohol, *isobutyl* alcohol, and *tert*-pentyl alcohol. Results for all of these test methods are reported in mass %. Test Method **D4815** includes procedures for calculating oxygenate concentration in volume % and mass oxygen content using the mass % oxygenate results.

7.1.10 *Corrosion, for Silver*—See **Annex A1** for a test method.

8. Sampling, Containers, and Sample Handling

8.1 The reader is strongly advised to review all intended test methods prior to sampling to understand the importance and effects of sampling technique, proper containers, and special handling required for each test method.

8.2 Correct sampling procedures are critical to obtain a sample representative of the lot intended to be tested. Use appropriate procedures in Practice **D4057** for manual method sampling and in Practice **D4177** for automatic method sampling, as applicable.

8.3 The correct sample volume and appropriate container selection are important decisions that can impact test results. Refer to Practice **D4306** for aviation fuel container selection for tests sensitive to trace contamination. Refer to Practice **D5854** for procedures on container selection and sample mixing and handling. For octane number determination, protection from light is important. Collect and store sample fuels in an opaque container, such as a dark brown glass bottle, metal can, or minimally reactive plastic container to minimize exposure to UV emissions from sources such as sunlight or fluorescent lamps.

8.4 For volatility determination of a sample, refer to Practice **D5842** for special precautions recommended for representative sampling and handling techniques.

9. Precision and Bias ⁷

9.1 The precision of each required test method for the properties specified is included in the standard applicable to each method, with the exception of Driveability Index. In many cases, the precision applicable to gasoline-oxygenate blends has not been established yet.

9.2 *Precision and Bias of Driveability Index (DI)*:

9.2.1 The following statements apply to the precision and bias of DI, which is a derived quantity not addressed in any other standard.⁷

9.2.2 The precision of DI is a function of the individual precisions of the 10 %, 50 %, and 90 % evaporated temperatures from Test Method **D86**. The precisions of these percent evaporated temperatures vary for different volatilities (for example, above and below 65.5 kPa (9.5 psi) vapor pressure) and with different distillation curve slopes.

9.2.3 *Repeatability*—The difference between two successive DI determinations using Test Method **D86** results, where the two test results were obtained by one operator with the same apparatus under constant operating conditions on identical test material, would in the long run, in normal and correct operation of the test method, exceed 9°C (17°F) derived units in only one case in twenty.

9.2.4 The repeatability value was calculated using the precision data from Test Method **D86** and average distillation characteristics from the 1994 through 1998 ASTM Committee D02 Interlaboratory Crosscheck Program for Motor Gasoline and from the 1997 and 1998 ASTM Committee D02 Interlaboratory Crosscheck Program for Reformulated Gasoline.

⁷ Supporting data (calculations) have been filed at ASTM International Headquarters and may be obtained by requesting Research Report D02-1468.

9.2.5 *Reproducibility*—The difference between two single and independent DI determinations using Test Method **D86** results, where the two test results were obtained by different operators in different laboratories on identical test material, would in the long run, in normal and correct operation of the test method, exceed 27°C (48°F) derived units in only one case in twenty.

9.2.6 The reproducibility values were determined directly using the distillation data from each laboratory participating in cooperative programs to calculate DI. The data used to calculate DI were available from the 1994 through 1998 ASTM Committee D02 Interlaboratory Crosscheck Program for Motor Gasoline, the 1997 and 1998 ASTM Committee D02 Interlaboratory Crosscheck Program for Reformulated Gasoline, the Auto/Oil Air Quality Improvement Research Program, the Auto/Oil AAMA Gasoline Inspections Program, and the 1995 to 1996 CRC volatility program.

9.2.7 *Bias*—Since there is no acceptable reference material suitable for determining bias for DI, bias has not been determined.

10. Keywords

10.1 alcohol; antiknock index; automotive fuel; automotive gasoline; automotive spark-ignition engine fuel; copper strip corrosion; corrosion; distillation; driveability; Driveability Index; EPA regulations; ethanol; ether; fuel; gasoline; gasoline-alcohol blend; gasoline-ethanol blend; gasoline-ether blend; gasoline-oxygenate blend; induction period; lead; leaded fuel; methanol; MTBE; octane number; octane requirement; oxidation stability; oxygenate; oxygenate detection; phase separation; phosphorous; solvent-washed gum; sulfur; $T_{V/L} = 20$; unleaded fuel; vapor-liquid ratio; vapor lock; vapor pressure; volatility; water tolerance

ANNEX

(Mandatory Information)

A1. TEST METHOD FOR CORROSIVENESS OF SILVER FROM PETROLEUM PRODUCTS BY SILVER STRIP TEST

A1.1 Scope

A1.1.1 This test method covers the determination of the corrosiveness to silver of automotive gasoline having a vapor pressure no greater than 124 kPa (18 psi) at 37.8°C (100°F).

A1.1.2 The values stated in SI units are to be regarded as the standard. The values in parentheses are for information only.

A1.1.3 *This standard does not purport to address all of the safety concerns, if any, associated with its use. It is the responsibility of the user of this standard to establish appropriate safety and health practices and determine the applicability of regulatory requirements prior to use. For specific warning statements, see **A1.6.1**, and **A1.7**.*

A1.2 Referenced Documents

A1.2.1 *ASTM Standards*.⁸

D3241 Test Method for Thermal Oxidation Stability of Aviation Turbine Fuels (JFTOT Procedure)

D4057 Practice for Manual Sampling of Petroleum and Petroleum Products

D4177 Practice for Automatic Sampling of Petroleum and Petroleum Products

E1 Specification for ASTM Liquid-in-Glass Thermometers

A1.2.2 *ASTM Adjunct*:

Color Standard for Tube Deposit Rating⁹

⁸ For referenced ASTM standards, visit the ASTM website, www.astm.org, or contact ASTM Customer Service at service@astm.org. For *Annual Book of ASTM Standards* volume information, refer to the standard's Document Summary page on the ASTM website.

⁹ Available from ASTM International Headquarters. Order Adjunct No. **ADJD3241**. Original adjunct produced in 1986.

A1.3 Summary of Test Method

A1.3.1 A polished silver strip is immersed in a specific volume of the sample being tested and heated under conditions of temperature and time. At the end of the heating period, the silver strip is removed, washed and the color and tarnish level assessed.

A1.4 Significance and Use

A1.4.1 Crude petroleum contains sulfur compounds, most of which are removed during refining. However, of the sulfur compounds remaining in the petroleum product, some can have a corroding action on various metals and this corrosivity is not necessarily related directly to the total sulfur content. The effect can vary according to the chemical types of sulfur compounds present. The silver strip corrosion test is designed to assess the relative degree of corrosivity of a petroleum product.

A1.5 Apparatus

A1.5.1 *Silver Strip Corrosion Pressure Vessel*, constructed from stainless steel according to the dimensions as given in **Fig. A1.1**. The vessel shall be capable of withstanding a test pressure of 700 kPa gage (100 psi). Alternative designs for the vessel's cap and synthetic rubber gasket may be used provided that the internal dimensions of the vessel are the same as those shown in **Fig. A1.1**. The internal dimensions of the pressure vessel are such that a nominal 25-mm by 150-mm test tube can be placed inside the pressure vessel.

A1.5.2 *Test Tubes*, of borosilicate glass of nominal 25-mm by 150-mm dimensions. The internal dimensions shall be checked as acceptable by use of a silver strip (see **A1.6.3**).

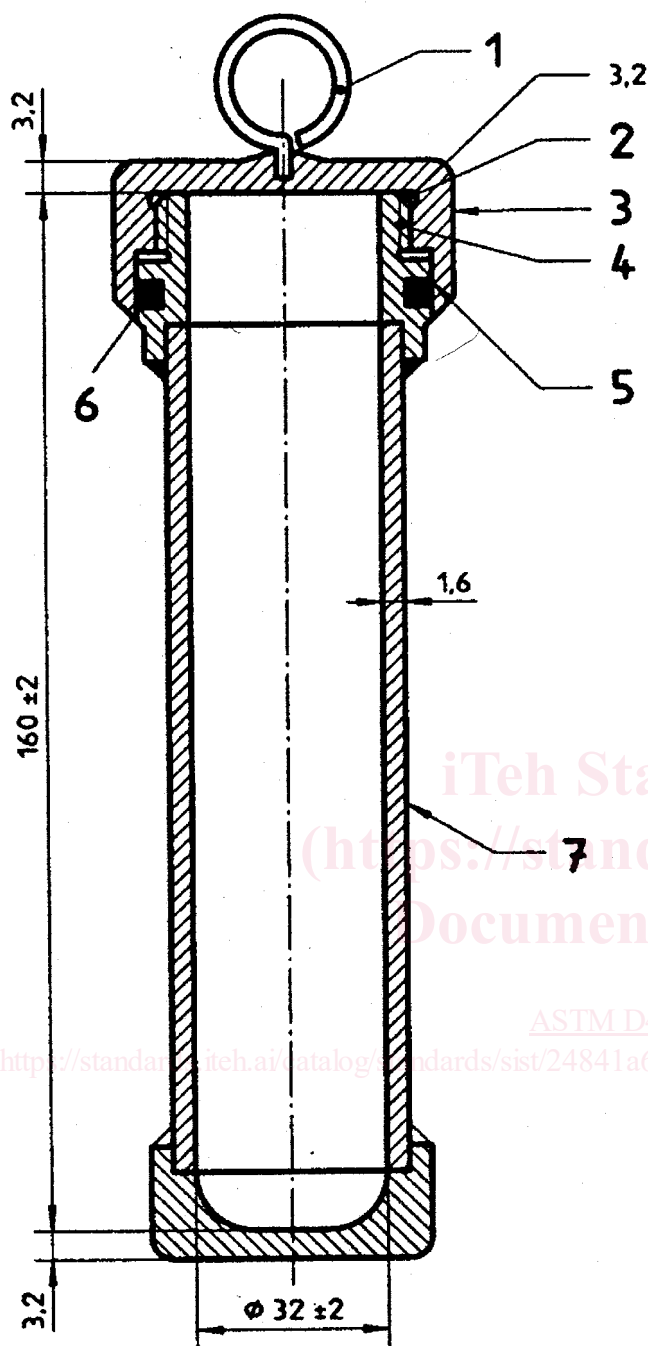

- Key:
- 1 Lifting eye
 - 2 Wide groove for pressure relief
 - 3 Knurled cap
 - 4 Twelve threads per inch NF thread or equivalent
 - 5 Camber inside cap to protect "O" ring when closing pressure vessel
 - 6 Synthetic rubber "O" ring without free sulfur
 - 7 Seamless tube

Material: stainless steel
 Welded construction
 Maximum test gage pressure: 700 kPa

NOTE 1—Dimensions in millimetres.
 NOTE 2—All dimensions without tolerance limits are nominal values.

FIG. A1.1 Pressure Vessel for Silver Strip Corrosion Test

When 30 mL of liquid is added to the test tube with the silver strip in it, a minimum of 5-mm of liquid shall be above the top surface of the strip.

A1.5.3 Test Bath:

A1.5.3.1 General—The test baths shall be able to maintain the test temperature to within $\pm 1^\circ\text{C}$ (2°F) of the required test temperature.

A1.5.3.2 Liquid Bath Used for Submerging Pressure Vessel(s)—The bath shall be deep enough to submerge one or more pressure vessels (see A1.5.1) completely during the test. As the bath medium, use water or any liquid that can be satisfactorily controlled to the sample test temperature. The bath shall be fitted with suitable supports to hold each pressure vessel in a vertical position when submerged.

A1.5.4 Temperature Sensing Device (TSD), capable of monitoring the desired test temperature in the bath to within an accuracy of $\pm 1^\circ\text{C}$ (2°F) or better. The ASTM 12C (12F) (see Specification E1) or IP 64C (64F) total immersion thermometers have been found suitable to use in the test. If used, no more than 10-mm (0.4-in.) of the mercury should extend above the surface of the bath at the test temperature.

A1.5.5 Polishing Vise, for holding the silver strip firmly without marring the edges while polishing. Any convenient type of holder (see Appendix X7) may be used provided that the strip is held tightly and that the surface of the strip being polished is supported above the surface of the holder.

A1.5.6 Viewing Test Tubes, flat glass test tubes, are convenient for protecting corroded silver strips for close inspection or storage (see Appendix X7 for the description of a flat-glass viewing tube). The viewing test tube shall be of such dimensions as to allow the introduction of a silver strip (see A1.6.3) and made of glass free of striae or similar defects.

A1.5.7 Forceps, with either stainless steel or polytetrafluoroethylene (PTFE) tips, for use in handling the silver strips, have been found suitable to use.

A1.5.8 Timing Device, electronic or manual, capable of accurately measuring the test duration within the allowable tolerance.

A1.6 Reagents and Materials

A1.6.1 Wash Solvent—2,2,4-trimethylpentane (isooctane) of minimum 99.75 % purity. (Warning—extremely flammable, see A1.7.)

A1.6.2 Surface Preparation/Polishing Materials, silicon carbide grit paper or cloth of varying degrees of fineness including 53 to 65- μm (240-grit) grade; also a supply of 105- μm (150-mesh) size silicon carbide grain or powder and absorbent cotton (cotton wool). A commercial grade is suitable, but pharmaceutical grade is most commonly available and is acceptable.

A1.6.3 Silver Strips Specification—Use strips 12.5 to 12.7-mm wide, 2.5 to 3.0-mm thick, and 17.0 to 19.0-mm long assaying at 99.9 % (m/m) Ag minimum. The strips may be used repeatedly but should be discarded when the strip's surface shows pitting or deep scratches that cannot be removed by the specified polishing procedure, or when the surface becomes deformed.

A1.6.4 *Ashless Filter Paper or Disposable Gloves*, for use in protecting the silver strip from coming in contact with the individual during final polishing.

A1.7 Hazards

A1.7.1 *Isooctane*:

Harmful if inhaled. Vapors may cause flash fire.

Keep away from heat, sparks, and open flame.

Keep container closed.

Use with adequate ventilation.

Avoid build-up of vapors and eliminate all sources of ignition, especially nonexplosion-proof electrical apparatus and heaters.

Avoid prolonged breathing of vapor or spray mist.

Avoid prolonged or repeated skin contact.

A1.7.2 *Gasoline (Unleaded or Leaded)*:

Keep away from heat, sparks, and open flame.

Keep container closed.

Use with adequate ventilation.

Avoid build-up of vapors and eliminate all sources of ignition, especially nonexplosion-proof electrical apparatus and heaters.

Avoid prolonged breathing of vapor or spray mist.

Avoid prolonged or repeated skin contact.

A1.8 Samples

A1.8.1 In accordance with Practice [D4057](#) or [D4177](#), or both, it is particularly important that all types of fuel samples, that pass a low-tarnish strip classification, be collected in clean, dark glass bottles, plastic bottles, or other suitable containers that will not affect the corrosive properties of the fuel. Avoid the use of tin plate containers for collection of samples, since experience has shown that they may contribute to the corrosiveness of the sample.

A1.8.2 Fill the containers as completely as possible and close them immediately after taking the sample. Adequate headspace in the container is necessary to provide room for possible thermal expansion during transport. It is recommended that volatile samples be filled between 70 and 80 % of the container's capacity. Take care during sampling to protect the samples from exposure to direct sunlight or even diffused daylight. Carry out the test as soon as possible after receipt in the laboratory and immediately after opening the container.

A1.8.3 If suspended water (that is, haze) is observed in the sample, dry by filtering a sufficient volume of sample through medium rapid qualitative filter paper, into the prescribed clean, dry test tube. Carry out this operation in a darkened room or under a light-protected shield.

A1.8.3.1 Contact of the silver strip with water before, during or after completion of the test run will cause staining, making it difficult to evaluate the strips.

A1.9 Preparation of Test Strips

A1.9.1 *Surface Preparation*—Remove all surface blemishes from all six sides of the strip obtained from a previous analysis (see [Note A1.1](#)). Use silicon carbide paper or cloth of such degrees of fineness as are needed to accomplish the desired results efficiently. Finish with 53 to 65- μm (240-grit) silicon

carbide paper or cloth, removing all marks that may have been made by other grades of paper used previously. Immerse the strip in 2,2,4-trimethylpentane from which it can be withdrawn immediately for final preparation (polishing) or in which it can be stored for future use.

NOTE A1.1—Only final preparation ([A1.9.2](#)) is necessary for commercially purchased pre-polished strips.

A1.9.1.1 As a practical manual procedure for surface preparation, place a sheet of silicon carbide paper or cloth on a flat surface and moisten it with 2,2,4-trimethylpentane. Rub the strip against the silicon carbide paper or cloth with a circular motion, protecting the strip from contact with the fingers by using ashless filter paper or wearing disposable gloves. Alternatively, the surface of the strip can be prepared by use of motor-driven machines using appropriate grades of dry paper or cloth.

A1.9.2 *Final Preparation*—For strips prepared in [A1.9.1](#) or new strips being used for the first time, remove a strip from the 2,2,4-trimethylpentane. To prevent possible surface contamination during final preparation, do not allow fingers to come in direct contact with the silver strips, by wearing disposable gloves or holding the strips in the fingers protected with ashless filter paper. Polish first the ends and then the sides with the 105- μm (150-mesh) silicon carbide grains or powder picked up with a pad of cotton (cotton wool) moistened with 2,2,4-trimethylpentane. Wipe vigorously with fresh pads of cotton (cotton wool) and subsequently handle without touching the surface of the strip with the fingers. Forceps have been found suitable to use. Clamp in a vise and polish the main surfaces with silicon-carbide grains on absorbent cotton. Do not polish in a circular motion. Rub in the direction of the long axis of the strip, carrying the stroke beyond the end of the strip before reversing the direction. Clean all metal dust from the strip by rubbing vigorously with clean pads of absorbent cotton until a fresh pad remains unsoiled. When the strip is clean, immediately immerse it in the prepared sample.

A1.9.2.1 It is important to polish the whole surface of the strip uniformly to obtain a uniformly stained strip. If the edges show wear (surface elliptical), they will likely show more corrosion than the center. The use of a vise (see [Appendix X7](#)) will facilitate uniform polishing.

A1.9.2.2 It is important to follow the order of preparation with the correctly sized silicon carbide material as described in [A1.9.1](#) and [A1.9.2](#). The final preparation is with 105- μm silicon carbide grains or powder. This is a larger grain size than the 53 to 65- μm paper used in the surface preparation stage. The reason for this use of larger silicon carbide grains in the final preparation is to produce asperities (controlled roughness) on the surface of the silver, which act as sites for the initiation of corrosion reactions.

A1.10 Procedure

A1.10.1 *Pressure Vessel Procedure*:

A1.10.1.1 Place 30 mL of sample, completely clear and free of any suspended or entrained water (see [A1.8.3](#)) into a chemically clean and dry 25-mm by 150-mm test tube. Within 1 min after completing the final preparation (polishing), slide the silver strip into the sample tube. Place the sample tube into