



Designation: ~~C1199-00 (Reapproved 2008)~~ Designation: C 1199 – 09^{ε1}

Standard Test Method for Measuring the Steady-State Thermal Transmittance of Fenestration Systems Using Hot Box Methods¹

This standard is issued under the fixed designation C 1199; the number immediately following the designation indicates the year of original adoption or, in the case of revision, the year of last revision. A number in parentheses indicates the year of last reapproval. A superscript epsilon (ϵ) indicates an editorial change since the last revision or reapproval.

^{ε1} NOTE—Editorial changes were made throughout in September 2009.

1. Scope

1.1 This test method covers requirements and guidelines and specifies calibration procedures required for the measurement of the steady-state thermal transmittance of fenestration systems installed vertically in the test chamber. This test method specifies the necessary measurements to be made using measurement systems conforming to ~~either Test Methods C236, C976, or Method C 1363~~ for determination of fenestration system thermal transmittance.

NOTE 1—This test method allows the testing of projecting fenestration products (that is, garden windows, skylights, and roof windows) installed vertically in a surround panel. Current research on skylights, roof windows, and projecting products hopefully will provide additional information that can be added to the next version of this test method so that skylight and roof windows can be tested horizontally or at some angle typical of a sloping roof.

1.2 This test method refers to the thermal transmittance, U , ~~and the corresponding thermal resistance, R , of a fenestration system installed vertically in the absence of solar and air leakage effects.~~ of a fenestration system installed vertically in the absence of solar radiation and air leakage effects.

NOTE 2—The methods described in this document may also be adapted for use in determining the thermal transmittance of sections of building wall, and roof and floor assemblies containing thermal anomalies, which are smaller than the hot box metering area.

~~1.3 This test method describes how to determine a fenestration product's (also called test specimen) thermal transmittance,~~
1.3 This test method describes how to determine the thermal transmittance, U_S , ~~at well-defined environmental conditions. The thermal transmittance, which is sometimes called the air-to-air U -factor, of a fenestration product (also called test specimen) at well-defined environmental conditions. The thermal transmittance is also a reported test result from Test Methods C236, C976, and Method C 1363. If only the thermal transmittance is reported using this test method, the test report must also include a detailed description of the environmental conditions in the thermal chamber during the test as outlined in 4.3–10.1.14.~~

1.4 For rating purposes, this test method also describes how to calculate a standardized thermal transmittance, U_{ST} , which can be used to compare test results from laboratories with ~~vastly different weather side wind directions and thermal chamber configurations, and can also be used facilitates the comparison to directly compare to calculated results from current computer programs for determining results from computer programs that use standard heat transfer coefficients to determine the thermal transmittance of fenestration products. Although this test method specifies two methods of calculating the standardized thermal transmittance, only the standardized thermal transmittance result from one method is reported for each test. One standardized thermal transmittance calculation procedure is the Calibration Transfer Standard (CTS) method Method and another is the area weighting Area Weighting (AW) method Method (see 4.3 and Section 89 for further descriptions of these two methods). The area weighting Area Weighting method requires that the surface temperatures on both sides of the test specimen be directly measured as specified in Practice E 1423 in order to determine the surface heat transfer coefficients on the fenestration product during the test. The CTS method Method does not use the measured surface temperatures on the test specimen and instead utilizes the calculation of equivalent surface temperatures from calibration data to determine the test specimen surface heat transfer coefficients. The area weighting (AW) method AW shall be used whenever the thermal transmittance, U_S , is greater than $3.4 \text{ W}/(\text{m}^2 \cdot \text{K})$ [$0.6 \text{ Btu}/(\text{hr} \cdot \text{ft}^2 \cdot \text{K})$] [$0.6 \text{ Btu}/(\text{hr} \cdot \text{ft}^2 \cdot ^\circ\text{F})$], or when the ratio of test specimen projected surface area to wetted (that is, total heat transfer or developed) surface area on either side of the test specimen is less than 0.80. Otherwise the CTS method Method shall be used to standardize the thermal transmittance results.~~

1.5 A discussion of the terminology and underlying assumptions for measuring the thermal transmittance are included.

¹ This test method is under the jurisdiction of ASTM Committee C16 on Thermal Insulation and is the direct responsibility of Subcommittee C16.30 on Thermal Measurement.

Current edition approved Oct. 15, 2008; June 1, 2009. Published July 2009. Originally approved in 1991. Last previous edition approved in 2008 as C 1199 – 00 (2008).

1.6 The values stated in SI units are to be regarded as the standard. The values given in parentheses are provided for information purposes only.

1.7 *This standard does not purport to address all of the safety concerns, if any, associated with its use. It is the responsibility of the user of this standard to establish appropriate safety and health practices and determine the applicability of regulatory limitations prior to use.*

2. Referenced Documents

2.1 ASTM Standards:

C 168 Terminology Relating to Thermal Insulation

C 177 Test Method for Steady-State Heat Flux Measurements and Thermal Transmission Properties by Means of the Guarded-Hot-Plate Apparatus ~~E236 Test Method for Steady-State Thermal Performance of Building Assemblies by Means of a Guarded Hot Box~~

C 518 Test Method for Steady-State Thermal Transmission Properties by Means of the Heat Flow Meter Apparatus ~~E976 Test Method for Thermal Performance of Building Assemblies by Means of a Calibrated Hot Box~~

iTeh Standards
(<https://standards.itih.ai>)
Document Preview

C 1045 Practice for Calculating Thermal Transmission Properties Under Steady-State Conditions

C 1114 Test Method for Steady-State Thermal Transmission Properties by Means of the Thin-Heater Apparatus

C 1363 Test Method for Thermal Performance of Building Materials and Envelope Assemblies by Means of a Hot Box Apparatus

E 283 Test Method for Determining Rate of Air Leakage Through Exterior Windows, Curtain Walls, and Doors Under Specified Pressure Differences Across the Specimen

E 631 Terminology of Building Constructions

E 783 Test Method for Field Measurement of Air Leakage Through Installed Exterior Windows and Doors

E 1423 Practice for Determining Steady State Thermal Transmittance of Fenestration Systems

2.2 ISO Standards:

ISO 8990 Thermal Insulation—Determination of Steady-State Thermal Transmission Properties—Calibrated and Guarded Hot Box²

ISO12567-1:2000 Thermal Insulation—Determination of Thermal Resistance of Components—Hot Box Method for Windows and Doors²

ISO12567-1 Thermal Insulation—Thermal Performance of Windows and Doors—Determination of Thermal Transmittance by Hot Box Method—Part 1 Complete Windows and Doors²

ISO12567-2 Thermal Insulation—Determination of Thermal Transmittance by Hot Box Method—Part 2: Roof Windows and Other Projecting Windows²

2.3 Other Standards:

NFRC 100-97-100 –2004 Procedure for Determining Fenestration Product Thermal U-factors³

NFRC 10 –2004 Procedure for Measuring the Steady-State Thermal Transmittance of Fenestration Systems³

BS874 Part 3, Section 3.1, 1987, British Standard Methods for Determining Thermal Insulation Properties, (Part 3, Tests for

² Available from American National Standards Institute (ANSI), 25 W. 43rd St., 4th Floor, New York, NY 10036, <http://www.ansi.org>.

³ Available from National Fenestration Rating Council, 1300 Spring Street, Suite 120, Silver Spring, MD 20910.

³ Available from National Fenestration Rating Council, 6305 Ivy Lane, Suite 140, Greenbelt, MD 20770.

Thermal Transmittance and Conductance, Section 3.1) Guarded Hot Box Method⁴
 BS874 Part 3, Section 3.2, 1990, British Standard Methods for Determining Thermal Insulation Properties, Part 3, Tests for
 Thermal Transmittance and Conductance, Section 3.2 Calibrated Hot Box Method⁴
 ASHRAE Fundamentals Handbook, 1997 ASHRAE Handbook-Fundamentals 2009⁵

3. Terminology

3.1 *Definitions*—Definitions and terms are in accordance with definitions in Terminologies E 631 and C 168, from which the following have been selected and modified to apply to fenestration systems. See Fig. 1 for temperature locations.

3.2 *Definitions of Terms Specific to This Standard:*

3.2.1 *apparent thermal conductance*—A thermal conductance assigned to a material that exhibits thermal transmission by several modes of heat transfer resulting in property variation with specimen thickness, or surface emittance.

3.2.2 *calibration transfer standard, n*—an insulation board that is faced with glazing, and instrumented with temperature sensors between the glazing and the insulation board core, which is used to calibrate the surface resistances and the surround panel (see—an insulation board with a known measured thermal conductance that is faced with glazing, and instrumented with temperature sensors either between the glazing and the insulation board core or on the exterior surface of the glazing, which is used to calibrate the surface resistances and the surround panel (see Annex A1 for design guidelines for calibration transfer standards).

3.2.2 *overall thermal resistance, R_{s, n}*—the temperature difference between the environments on the two sides of a body or assembly when a unit heat flow per unit area is established through the body or assembly under steady-state conditions. It is defined as follows:

(1) $RS = 1/U_S$ for design guidelines for Calibration Transfer Standards).

3.2.3 *projecting products, n*

and using the area weighting (AW) method:

3.2.3.1 *Discussion*—The calculation of the standardized thermal transmittance, U_{ST} , assumes that only the surface heat transfer coefficients change from the calibrated standardized values for the conditions of the test. This assumption may not be valid if the

⁴ Available from British Standards Institute (BSI), 389 Chiswick High Rd., London W4 4AL, U.K., <http://www.bsi-global.com>.

⁵ Available from American Society of Heating, Refrigerating, and Air-Conditioning Engineers, Inc. (ASHRAE), 1791 Tullie Circle, NE, Atlanta, GA 30329, <http://www.ashrae.org>.

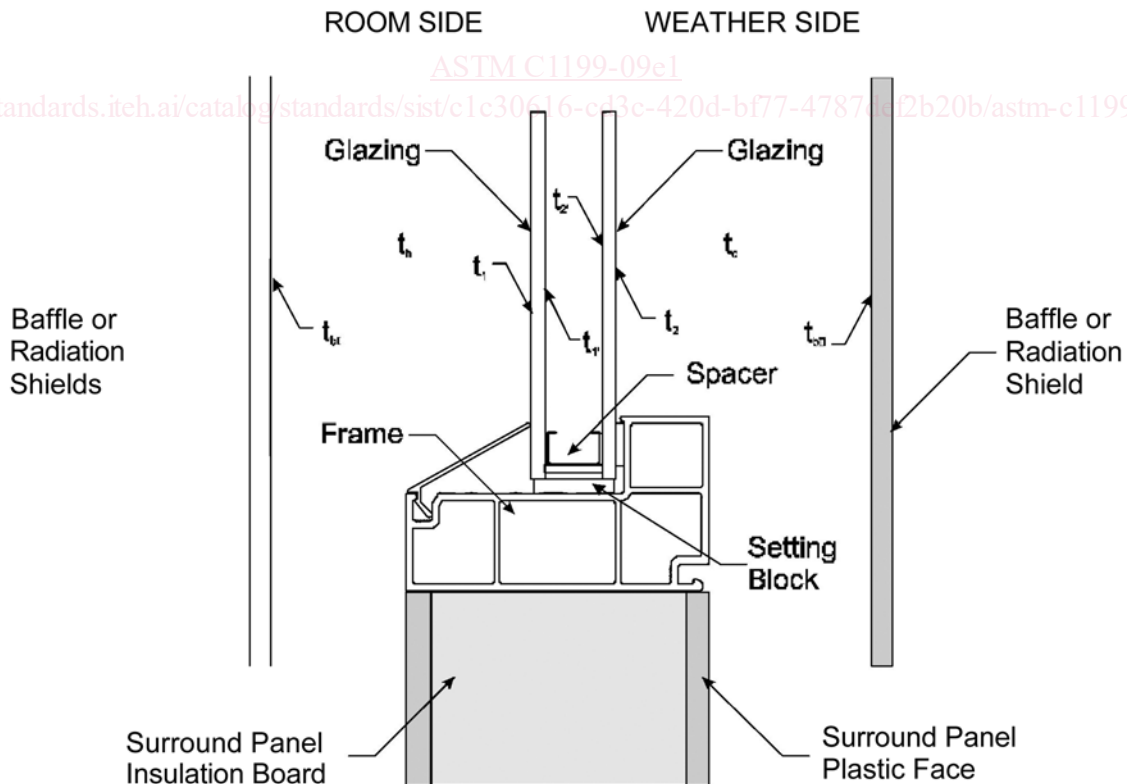

FIG. 1 Schematic Representation of Various Temperatures for Fenestration Systems

surface temperature differentials for the standardized calibration conditions are different from the surface temperature differential that existed for the fenestration product during the test procedure. Therefore, the standardized thermal transmittance should only be considered as an approximation for use in comparing with calculated thermal transmittance values with standardized surface heat transfer coefficients.—a non-planar product where the glazing projects outward past the cold side surround panel surface plane (that is, skylights, garden windows).

3.2.4 *surface resistance*—standardized thermal transmittance, n —the temperature difference between an isothermal surface and its surroundings when a unit heat flow per unit area is established between the surface and the surroundings under steady-state conditions by the combined effects of convection and radiation. Subscripts h and c are used to differentiate between room side and weather side surface resistances, respectively. Surface resistances are calculated as follows:

— U_{ST} , the heat transmission in unit time through unit area of a test specimen and standardized boundary air films, induced by unit temperature difference between the environments on each side.

3.2.5 *surface heat transfer coefficient*, n

when:

when:

3.2.5.2 *Discussion*—When testing inhomogeneous test specimens, the test specimen surface temperatures and surface heat transfer coefficients will not be exactly the same as those obtained using the calibration transfer standard. As a consequence, the surface heat transfer coefficients obtained using the calibration transfer standard cannot be unambiguously defined and hence a test specimen conductance cannot be defined and measured. For inhomogeneous test specimens, only the thermal transmittance, U_S , can be defined and measured. It is therefore essential to calibrate with surface heat transfer coefficients on the Calibration Transfer Standard (CTS) which are as close as possible to the conventionally accepted values for building design. Likewise, it would be desirable to have a surround panel that closely duplicates the actual wall where the fenestration system would be installed. However, due to the wide variety of fenestration opening designs and constructions, this is not feasible. Furthermore, for high resistance fenestration systems installed in fenestration opening designs and constructions that are thermal bridges, the large relative amount of heat transfer through the thermal bridge will cause the relatively small amount of heat transfer through the fenestration system to have a larger than desirable error. As a result of the points stated above, the calculation of a specimen thermal conductance or resistance (surface to surface) from a measured thermal transmittance and the calculated surface heat transfer coefficients is not part of the basic measurement procedure. However, by using the CTS method or the area weighting (AW) method described in Section 8 it is possible to obtain a standardized thermal transmittance, U_{ST} , which is a rather useful tool for the evaluation and comparison of experimental results for fenestration systems with computer calculations of the thermal transmittance.— h , (sometimes called *surface conductance* or *film coefficient*.) the time rate of heat flow from a unit area of a surface to its surroundings, induced by a unit temperature difference between the surface and the environment.

3.2.6 *surround panel* (sometimes called the *mask*, *mask wall*, or *homogeneous wall*), n —a homogeneous panel with an opening where the test specimen is installed (see 5.1.2 for a description of a surround panel.) —a homogeneous panel with an opening where the Calibration Transfer Standard or the test specimen is installed. When there is no test specimen aperture, or the opening is filled with the same thickness of surround panel assembly, it is called a characterization panel. (see 5.1.1.1, and Annex A11 of Test Method C 1363 for a description of surround panels and characterization panels.)

3.2.7 *test specimen*, n —the fenestration system or product being tested.

3.2.8 *test specimen thermal transmittance*, U_S (sometimes called the overall coefficient of heat transfer or air-to-air U-factor) thermal transmittance, n —the heat transfer in unit time through unit area of a test specimen and its boundary air films, induced by unit temperature difference between the environments on each side. It is determined as follows:

3.3 *Symbols*—The symbols, terms, and units used in this test method are as follows:

A_h	= total heat transfer (or developed) surface area of test specimen on room side, m^2 ,
A_c	= total heat transfer (or developed) surface area of test specimen on weather side, m^2 ,
A_{b1}	= area of room side baffle and all other surfaces in view of the test specimen, m^2 ,
A_{b2}	= area of weather side baffle and all other surfaces in view of the test specimen, m^2 ,
A_S	= projected area of test specimen (same as test specimen aperture in surround panel), m^2 ,
A_{sp}	= projected area of surround panel (does not include test specimen aperture in surround panel), m^2 ,
α	= absorbance of surface,
C_g	= apparent thermal conductance of glass or acceptable transparent plastic facing on calibration transfer standard, $W/(m^2 \cdot K)$,
C_{sp}	= apparent thermal conductance of surround panel (surface to surface), $W/(m^2 \cdot K)$, determined by means of Practice C 1045 used with either Test Method C 177, Test Method C 518 or Test Method C 1114,

$C_{ts[core]}$	= apparent thermal conductance of calibration transfer standard core, $W/(m^2 \cdot K)$, determined by means of and Practice C 1045 used with either Test Method C 177, Test Method C 518 or Test Method C 1114
$C_{ts[assembly]}$	= apparent thermal conductance of calibration transfer standard assembly, $W/(m^2 \cdot K)$, determined by means of Practice C 1045 used with either Test Method C 177 and Test Method C 518 or Test Method C 1114.
e	= total hemispherical emittance of surface;
h_{STh}	= standardized surface heat transfer coefficient, room side, $(W/m^2 \cdot K)$;
h_{STc}	= standardized surface heat transfer coefficient, weather side, $(W/m^2 \cdot K)$;
h_h	= surface heat transfer coefficient, room side, $W/(m^2 \cdot K)$;
h_c	= surface heat transfer coefficient, weather side, $W/(m^2 \cdot K)$;
K_c	= convection coefficient, $W/(m^2 \cdot K^{1.25})$;
L	= length of heat flow path, m;
Q	= time rate of heat flow through the total surround panel/test specimen system, W;
Q_c	= time rate of convective heat flow from test specimen surface, W;
Q_{fl}	= time rate of flanking loss heat flow around surround panel, W;
Q_r	= time rate of net radiative heat flow from test specimen surface to the surroundings, W;
Q_S	= time rate of heat flow through the test specimen, W;
Q_{sp}	= time rate of heat flow through the surround panel as determined from measured conductance C_{ts} and area weighted surround panel surface temperatures, W;
q	= heat flux (time rate of heat flow through unit area), W/m^2 ;
q_S	= heat flux through the test specimen, W/m^2 ;
q_{r1}	= net radiative heat flux to the room side of the test specimen, W/m^2 ;
q_{r2}	= net radiative heat flux from the weather side of the test specimen, W/m^2 ;
q_{c1}	= convective heat flux to the room side of the test specimen, W/m^2 ;
q_{c2}	= convective heat flux from the weather side of the test specimen, W/m^2 ;
ρ	= reflectance of surface;
r_h	= surface resistance, room side, $m^2 \cdot K/W$;
r_c	= surface resistance, weather side, $m^2 \cdot K/W$;
R_S	= overall thermal resistance of test specimen (air to air under test conditions), $m^2 \cdot K/W$;
t_{b1}	= equivalent radiative baffle surface temperature, room side, K or °C;
t_{b2}	= equivalent radiative baffle surface temperature, weather side, K or °C;
t_h	= average temperature of room side air, °C;
t_c	= average temperature of weather side air, °C;
t_1	= average area weighted temperature of test specimen room side surface, K or °C;
t_2	= average area weighted temperature of test specimen weather side surface, K or °C;
t_{sp1}	= area-weighted room side surround panel surface temperature, K or °C
t_{sp2}	= area-weighted weather side surround panel surface temperature, K or °C
t_{17}	= average area weighted temperature of room side glass/core interface of calibration transfer standard, K or °C;
t_{27}	= average area weighted temperature of weather side glass/core interface of calibration transfer standard, K or °C;
U_S	= thermal transmittance of test specimen (air to air under test conditions), $W/(m^2 \cdot K)$;
U_{ST}	= standardized thermal transmittance of test specimen, $W/(m^2 \cdot K)$;
$U_{ST[AW]}$	= standardized thermal transmittance of test specimen determined using measured Area Weighted [AW] surface temperatures (air to air), $W/(m^2 \cdot K)$, and
$U_{ST[CTS]}$	= standardized thermal transmittance of test specimen determined using Calibration Transfer Standard [CTS] surface heat transfer coefficients (air to air), $W/(m^2 \cdot K)$.

4. Significance and Use

4.1 This test method details the calibration and testing procedures and necessary additional temperature instrumentation required in applying Test Method C 1363 to measure the thermal transmittance of fenestration systems mounted vertically in the thermal chamber.

4.2 The thermal transmittance of a test specimen is affected by its size and three-dimensional geometry. Care must be exercised when extrapolating to product sizes smaller or larger than the test specimen. Therefore, it is recommended that fenestration systems be tested at the recommended sizes specified in Practice E 1423 or NFRC 100.

4.3 Since both temperature and surface heat transfer coefficient conditions affect results, use of recommended conditions will assist in reducing confusion caused by comparing results of tests performed under dissimilar conditions. Standardized test conditions for determining the thermal transmittance of fenestration systems are specified in Practice E 1423 and Section 6.2. The performance of a test specimen measured at standardized test conditions is potentially different than the performance of the same fenestration product when installed in the wall of a building located outdoors. Standardized test conditions often represent extreme summer or winter design conditions, which are potentially different than the average conditions typically experienced by a fenestration product installed in an exterior wall. For the purpose of comparison, it is essential to calibrate with surface heat transfer coefficients on the Calibration Transfer Standard (CTS) which are as close as possible to the conventionally accepted values for

building design; however, this procedure can be used at other conditions for research purposes or product development.

4.4 Similarly, it would be desirable to have a surround panel that closely duplicates the actual wall where the fenestration system would be installed. Since there are such a wide variety of fenestration system openings in North American residential, commercial and industrial buildings, it is not feasible to select a typical surround panel construction for installing the fenestration system test specimen. Furthermore, for high resistance fenestration systems installed in fenestration opening designs and constructions that have thermal bridges, the large relative amount of heat transfer through the thermal bridge will cause the relatively small amount of heat transfer through the fenestration system to have a larger than desirable error. For this reason, the Calibration Transfer Standard and test specimen are installed in a homogeneous surround panel constructed from materials having a relatively high thermal resistance. Installing the test specimen in a relatively high thermal resistance surround panel places the focus of the test on the fenestration system thermal performance alone. Therefore, it is important to recognize that the thermal transmittance results obtained from this test method are for ideal laboratory conditions, and should only be used for fenestration product comparisons unless the thermal bridge effects that have the potential to occur due to the specific design and construction of the fenestration system opening are included in the analysis.

4.5 This test method does not include procedures to determine the heat flow due to either air movement through the specimen or solar radiation effects. As a consequence, the thermal transmittance results obtained do not reflect performances that may be expected from field installations. It is possible to use the results from this test method as input to annual energy performance analyses which include solar, and air leakage effects to get a better estimate of how the test specimen would perform when installed in an actual building. To determine the Solar Heat Gain Coefficient of fenestration products, refer to NFRC 200. To determine air leakage for windows and doors, refer to Test Methods E 283 and E 783.

4.6 It is important to recognize that the thermal transmittance, U_S , value determined in Section 8 is the only true experimental measurement result of this test method. The “standardized” thermal transmittance value, U_{ST} , obtained by either the Calibration Transfer Standard (CTS) or Area Weighting (AW) methods described in Section 8 include adjustments to the thermal transmittance value based on results from calibration runs described in Section 6. The standardized thermal transmittance is useful for two reasons; it facilitates comparison of test results between different laboratories with different thermal chamber geometries and configurations, and it improves the comparison between test results and computer simulation results. Due to the differences in size, geometry, and climate chamber air flow permitted by this test method, Test Method C 1363, and Practice E 1423, there can be significant variations in the local surface heat transfer coefficients on the same test specimen installed in different laboratories even though these laboratories measured identical surface heat transfer coefficients on their Calibration Transfer Standards. Inter-Laboratory Comparisons conducted by the NFRC have shown that the effect of this variation is reduced if the standardized thermal transmittance is used for comparison instead of the thermal transmittance. The standardized thermal transmittance is also a useful tool for the evaluation and comparison of experimental results of fenestration systems with computer calculations of the thermal transmittance that are made because the current Historically, computer calculation methods (NFRC 100) for determining the thermal transmittance were not capable of applying the actual surface heat transfer coefficients that exist on the test specimen while testing at standardized conditions. These current computer calculation methods assumed that uniform standardized surface heat transfer coefficients exist on the indoor and outdoor fenestration product surfaces. Although the next generation of computer simulation programs includes improved radiation heat transfer algorithms, which generate non-uniform surface heat transfer coefficients, the standardized thermal transmittance remains to be a useful tool when comparing test results to computer modeling results.

4.6.1 It is important to recognize that due to radiation effects, the room side or weather side temperature (t_r and t_c , respectively), has the potential to differ from the respective room side or weather side baffle temperatures (t_{b1} and t_{b2} , respectively). If there is a difference of more than $\pm 1^\circ\text{C}$ ($\pm 2^\circ\text{F}$), either on the room side or weather side, the radiation effects shall be accounted for as described in Sections 6 and 9 to maintain accuracy in the calculated surface heat transfer coefficients. Calculating the radiation exchange for highly conductive test specimens or projecting fenestration products as described in Annex A2 is not a trivial task.

4.6.2 The calculation of the standardized thermal transmittance assumes that only the surface heat transfer coefficients change from the calibrated standardized values for the conditions of the test. This assumption is possibly not valid if the surface temperature differentials for the standardized calibration conditions are different from the surface temperature differential that exists on the test specimen during the test. Currently, specifications for the Calibration Transfer Standard give it a thermal transmittance of $1.7 \text{ W}/(\text{m}^2\cdot\text{K})$ [$0.3 \text{ Btu}/(\text{hr}\cdot\text{ft}^2\cdot^\circ\text{F})$]. Accordingly, the calculation of the standardized thermal transmittance produces the least error when performed on test specimens with a similar thermal transmittance.

4.6.3 It is important to note that the standardized surface heat transfer coefficients, h_h and h_c , as calibrated prior to testing a fenestration product using an appropriately sized Calibration Transfer Standard (CTS) have the potential to differ from the surface heat transfer coefficients that exist during a hot box test on a specific test specimen. Fenestration systems usually have frame and sash surfaces that introduce two- and three-dimensional convective heat transfer effects which result in variable surface heat transfer coefficients, which differ from the uniform standardized values. As a result of this, the test specimen surface heat transfer coefficients will differ from those obtained with the non-framed, essentially flat Calibration Transfer Standard tested under the same conditions. In this standardizing procedure, it is assumed that the differences are small enough so that the calibration surface heat transfer coefficients can be used to calculate equivalent test specimen average surfaces temperatures, t_1 and t_2 , in order to estimate

the actual test specimen surface heat transfer coefficients. It is important to recognize that this assumption will not be accurate for all fenestration products, especially for high thermal transmittance products where the surface heat transfer coefficients are a major portion of the overall thermal resistance and also for fenestration products with significant surface projections (for example, skylights, roof windows, garden windows) where the surface heat transfer coefficients are quite different from the standardized values.

4.6.4 In these situations, it is important to attempt to measure the test specimen surface temperature distributions and then calculate directly the test specimen average area weighted surface temperatures, t_1 and t_2 . This area weighting (AW) method also has problems in that the placement of temperature sensors to get an accurate area weighting is not known, especially on high conductivity horizontal surfaces that act as heat transfer extended surfaces (that is, fins). In addition, the placement of many temperature sensors on the test specimen surfaces will affect the velocity fields in the vicinity of these surfaces which will affect the surface temperatures and surface heat transfer coefficients.

5. Apparatus

5.1 *General Thermal Chamber*—This section specifies the additional equipment and instrumentation necessary to calibrate, and measure the thermal transmittance of fenestration systems using a thermal chamber as described in Test Method C 1363. Keep in mind that Test Method C 1363 describes the overall construction, calibration and operation of the thermal chamber and surround panel as well as additional air flow measurements and power measurements that are not described in detail in this test method.

5.1.1 Equipment:

5.1.1.1 *Surround Panel*—As explained in 4.4 there is the potential for a strong interaction between the heat flow in an actual surrounding wall and the frame of the fenestration system. If the surrounding wall construction contains highly conductive materials, the heat flow through the fenestration system frame could be significantly changed. Since it is not feasible to select a typical wall to use as a surround panel, it is desirable to have a relatively high-resistance surround panel to minimize this “shorting” interaction so that the heat flow through the fenestration system itself can be measured as accurately as possible. This is especially true for the highly resistive “superwindows” currently being developed.

(1) A surround panel, consisting of a stable homogeneous thermal insulation material with a apparent thermal conductance at 24 °C not in excess of 0.03 W/(m · K) [0.21 (Btu · in)/(hr · ft² · °F)] and having a very low gas permeance (an air permeance less than 1.0E-10 m² has been found to be satisfactory), shall be provided for mounting the test specimen (see Fig. 2). Surround panels shall be constructed, characterized, and instrumented using the procedures described in Annex A11 of Test Method C 1363.

5.1.2 *Calibration Transfer Standard*—The test facility surface heat transfer coefficients shall be calibrated using a heat flux transducer Calibration Transfer Standard constructed as described in Annex A1 and illustrated in Fig. 3 (a) and Fig. 3(b). The Calibration Transfer Standard has a core material of known characteristics traceable to primary standards such as the guarded hot plate of a national standard laboratory. The projected dimensions and areas of the Calibration Transfer Standards need to cover the same range as the test specimen model sizes and tolerances as specified in Practice E 1423 or NFRC 100. A minimum of two Calibration Transfer Standards shall be used; one approximately the largest specimen size to be tested and one approximately the smallest specimen size to be tested. The Calibration Transfer Standard calibration coefficients (that is, h_p , h_c , and K) used to standardize the thermal transmittance shall be those from the Calibration Transfer Standard closest to the size of the test specimen. See 6.2 for the values of the standardized surface heat transfer coefficients required for using this test method for rating purposes.

NOTE 3—It is recommended that a minimum of three Calibration Transfer Standards be used that cover the range of test specimen model sizes that a laboratory plans to test. One approximately the smallest model size to be tested, one approximately the average model size to be tested, and one approximately the largest model size to be tested.

5.1.3 Instrumentation:

5.1.3.1 *Power measurements*—The total power to heaters, fans or blowers, and any significant power to instrument transducers within the metering box shall be measured or determined over the duration of the test. See 6.12 of Test Method C 1363 for a full description of power measurement requirements.

5.1.3.2 *Temperature measurements*—In addition to the air and surface area weighted temperature measurements specified in Test Method C 1363, the following temperature measurements are required:

(1) *Radiating surface temperatures*—The temperature of all surfaces (baffles, surround panel opening, box surfaces, shields, etc) exchanging radiation heat transfer with the test specimen using the same area weighing criteria as specified in Test Method C 1363.

(2) *Air temperatures*—The room side and weather side air stream temperatures in a plane parallel to the surround panel surfaces shall be measured as specified in 6.10.3.1 of Test Method C 1363. The air temperature sensors shall be located 75 mm (3 in.) from the surface of the surround panel. The rows and columns closest to the metering box walls shall be located at a minimum distance of 150 mm (6 in.) from each meter box wall. It is desirable to measure each of the air temperature thermocouples individually, but if the thermocouples are to be electrically averaged, ensure that the thermocouple leads within an averaged group are the same length and that each averaged group is confined to individual horizontal rows.

NOTE 4—The temperature sensor requirements given in 5.1.3.2, 5.1.3.2 (1), and 5.1.3.2 (2) are minimum requirements. Section 7.5.2 on temperature measurements requires additional temperature sensors which are dependent on the test specimen type. It is acceptable to use more temperature sensors if they provide more accurate average temperature (air and surface) values.

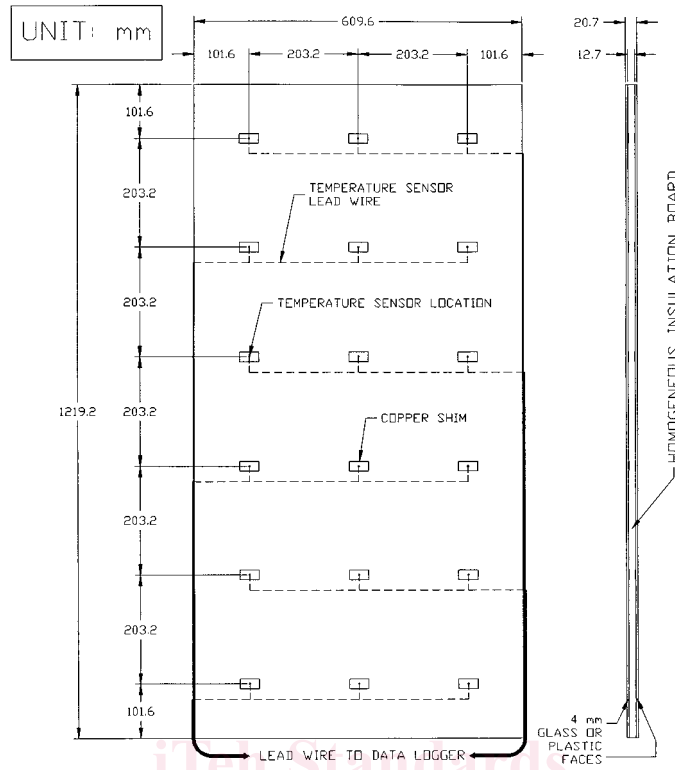

FIG. 3 (a) Example Calibration Transfer Standard Design Information
 FIG. 2 (a) Example Calibration Transfer Standard Design Information

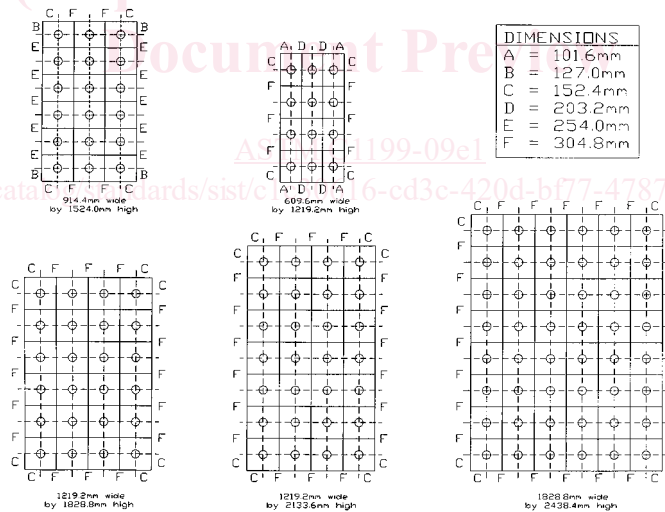

FIG. 3 (b) Minimum Temperature Sensors Array for Typical CTS

5.1.3.3 *Air leakage*—Practice E 1423 describes the equipment, instrumentation and methodology used to verify that all the Calibration Transfer Standards and test specimens are sealed in the surround panel before testing.

5.1.3.4 *Wind velocity measurements*—As stipulated in 7.5.4, both the weather and meter side wind velocity shall be measured and recorded at locations that represents free stream conditions for the duration of the test. A sensor with an accuracy of $\pm 5\%$ of the reading is required.

5.1.3.5 *Relative Humidity measurements*—Instrumentation shall be used to measure and record the Relative Humidity within the metering box for the duration of the test. It is also recommended that the Relative Humidity within the guard and climate chambers as well as the ambient laboratory environment be monitored.

5.1.3.6 *Glazing deflection*—Equipment or instrumentation, or both, used to measure the glazing deflection of multiple-pane glazing systems is required. Measurements shall be reported for each test specimen as specified in Section 8 of Practice E 1423

6. Calibration

6.1 *Calibration requirements*—A minimum of two calibration test procedures shall be performed to determine the metering box wall transducer and surround panel flanking loss coefficients, $[E_o + Q_{fl}]$, and to characterize the surface heat transfer coefficients on a Calibration Transfer Standard before testing actual fenestration products. The first calibration test requires that a continuous surround panel (with the test specimen aperture filled with the same material as the rest of the surround panel) be tested at standard test conditions in order to determine the metering box wall and surround panel heat transfer characteristics. In the second set of calibration tests, a Calibration Transfer Standard with its weather side face located 25 mm in from the weather side edge of the surround panel opening shall be mounted in the surround panel and tested at standardized conditions. Adjust the fans in the thermal chamber so that the surface heat transfer coefficients measured on both sides of the Calibration Transfer Standard are within a set tolerance of the standardized surface heat transfer coefficients (see 6.2). The design, construction and instrumentation of Calibration Transfer Standards are presented in Annex A1.

6.1.1 *Metering Box Wall Transducer and Flanking Loss Test Procedure:*

6.1.1.1 Install a continuous surround panel or *characterization panel* (one without a test specimen aperture, or with the aperture filled with surround panel material of equal thickness) in the thermal chamber and attach temperature sensors to both sides at the density described in Test Method C 1363, Annex 11. Seal the characterization panel as per 7.5 and Annex 11 of Test Method C 1363. The heat flow through the characterization panel as determined by its area, the surface temperature difference on both sides of the characterization panel, and the apparent thermal conductance of the characterization panel's materials (as determined by Test Methods C 177, C 518, or C 1114) is compared to the metered heat flow that is input into the metering chamber (after it is corrected for the heat flow through the metering chamber walls determined as per Annex A1 and Annex A6 of Test Method C 1363). Typically this test is performed at least three times for each characterization panel; one test with the guard chamber air temperature above the metering chamber air temperature, one with the guard and metering air temperature almost equal, and one test with the guard air temperature below the metering box air temperature. The results from these three tests are used to determine the metering box wall transducer and surround panel flanking loss coefficients, $[E_o + Q_{fl}]$, for each characterization panel. The thinnest and thickest surround panels shall be tested first, and if the differences between the metering box wall transducer and flanking loss coefficients are negligible, intermediate thicknesses of surround panel are not required to be tested. If the differences between the thickest and thinnest surround panels is significant then separate metering box wall transducer and surround panel flanking loss coefficients shall be determined for each combination of materials and thicknesses of surround panels and environmental conditions used for testing; as per Annex A6 of Test Method C 1363.

Note 5—It is convenient to measure the time constant of the thermal chamber and the surround panel at this time. The time constant is used to determine when a particular test has achieved steady-state conditions, and is determined using the process described in Section A10 of Test Method C 1363. A continuous surround panel (that is, with the test specimen aperture filled with surround panel material) can be used as a conservative estimate of the time constant of most window test specimens, which have a thermal capacity and diffusivity less than an equivalent sized surround panel material. Therefore it is useful to determine the time constant of a thermal chamber and surround panel at the same time that the flanking loss is determined.

6.1.2 *Calibration Transfer Standard Test Procedure:*

6.1.2.1 Install the Calibration Transfer Standard with the weather side surface 25 mm (1 in.) in from the surround panel weather side surface (see Fig. 4). Seal the cracks around the perimeter of the Calibration Transfer Standard with nonmetallic tape or caulking, or both, to prevent air leakage. It is desirable to measure each of the surface temperature thermocouples in the Calibration Transfer Standard individually, but if the thermocouples are to be electrically averaged, ensure the thermocouple leads within an averaged group are the same length and that each averaged group is confined to individual horizontal rows. The design construction and instrumentation of Calibration Transfer Standards are presented in Annex A1.

6.1.2.2 Establish, as per Test Method C 1363 steady-state thermal conditions for which the surround panel and Calibration Transfer Standard is to be calibrated and record the metering box and climate chamber fan speeds, measurements of power, temperature, and velocity. The methodology and criteria used to determine steady state for fenestration testing described in Note 23 in Section 10.11.3 of Test Method C 1363 is considered to be the minimum mandatory requirements.

6.1.3 *Calibration Transfer Standard Data Analysis:*

6.1.3.1 *Total heat flow*—The time rate of heat flow through the test assembly (surround panel and Calibration Transfer Standard), Q , is determined by the procedures specified in Test Method C 1363.

6.1.3.2 *Calibration Transfer Standard Heat Flow*— Q_s is calculated differently depending if the temperature sensors are located on the inside or the outside of the facing material:

(1) *CTS with interior thermocouples*—If the temperature sensors are located between the glazing and the core, the Calibration Transfer Standard Heat Flow, Q_s , is calculated as follows:

(1) — Q

$$S = Cts[core] \cdot AS \cdot (t1' - t2')$$

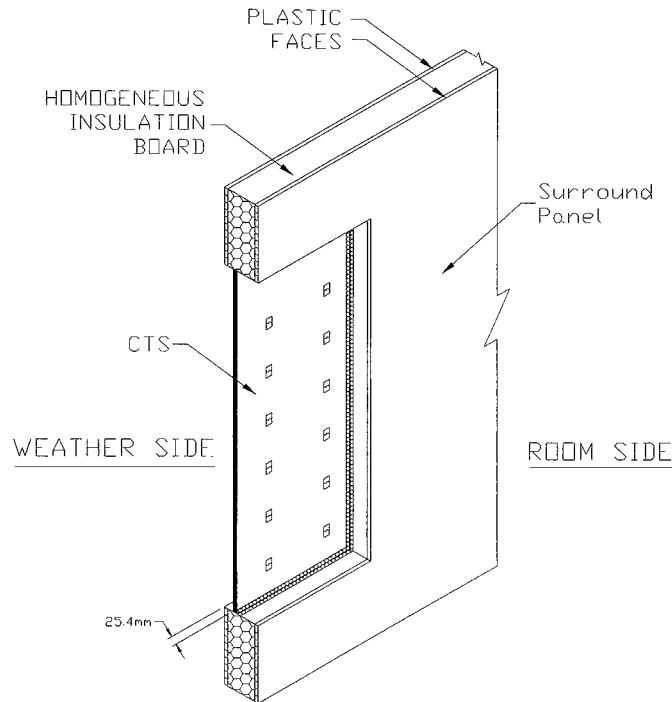

FIG.-2 4 Surround Panel With CTS

Cts[core]

where:

\dot{Q} = power delivered to the metering chamber by the heaters, fans, etc., which is corrected for the heat flow through the metering box walls, W;

C_{sp} = conductance of surround panel, $W/(m^2 \cdot K)$, as determined by either Test Methods C 177, C 518, or C 1114 and Practice C 1045, or C_{cts} = conductance of Calibration Transfer Standard core, $W/(m^2 \cdot K)$, as determined by either Test Methods C 177, C 518, or C 1114 and Practice C 1045, or

A = area of surround panel, m^2 ; and

t_{sp1} = area weighted average room side surround panel surface temperature, °C, and average equal area weighted temperature of room side glass/core interface of calibration standard, °C (see Fig. 1), and

t_{sp2} = area weighted average weather side surround panel surface temperature, °C, and average equal area weighted temperature of weather side glass/core interface of calibration standard, °C (see Fig. 1).

5.2.3 Calibration Transfer Standard Test Procedure:

5.2.3.1 Install the Calibration Transfer Standard with the weather side surface 25 mm (1 in.) in from the surround panel weather side surface (see Fig. 2). Seal the cracks around the perimeter of the Calibration Transfer Standard with nonmetallic tape or caulking, or both, to prevent air leakage. Each of the surface temperature thermocouples in the Calibration Transfer Standard should be individually measured, but if the thermocouples are to be electrically averaged, the thermocouple leads within an averaged group must be the same length and each averaged group must be confined to individual horizontal rows.

5.2.3.2 Establish, as per Test Method C1363 steady-state thermal conditions for which the surround panel and Calibration Transfer Standard are to be calibrated and record measurements of power, temperature, and velocity.

5.2.4 Calibration Transfer Standard Data Analysis:

5.2.4.1 Total heat flow—The time rate of heat flow through the test assembly (surround panel and Calibration Transfer Standard), \dot{Q} , is determined by the procedures specified in Test Methods C236, C976, or C1363.

5.2.4.2 Calibration Transfer Standard Heat Flow:

(2) CTS with exterior thermocouples—If the temperature sensors are located on the exterior surface of the glazing, the Calibration Transfer Standard Heat Flow, $Q_{s,S}$, is calculated as follows:

$$(2) \quad Q_S = C_{ts[assembly]} \cdot A_S \cdot (t_1 - t_2)$$

$$(2) \quad Q_S = C_{ts[assembly]} \cdot A_S \cdot (t_1 - t_2)$$

t₁

where:

C_{ts} [assembly] = conductance of Calibration Transfer Standard core, W/(m²•K), as determined by either Test Methods C 177, C 518, or C 1114 and Practice C 1045, including the core and facing materials, W/(m²•K), as determined by either Test Methods C 177, C 518, or C 1114 and Practice C 1045,

A_S = area of Calibration Transfer Standard, m²,

t_{T1} = average equal area weighted temperature of room side glass/core interface of calibration standard, °C (see Fig. 1), and equal area weighted average room side Calibration Transfer Standard surface temperature, °C,

t_{2T2} = average equal area weighted temperature of weather side glass/core interface of calibration standard, °C (see Fig. 1), equal area weighted average weather side calibration transfer standard surface temperature, °C,

5.2.4.3 Surround 6.1.3.3 Surround panel heat flow, Q_{sp} , is then:

$$Q_{sp} = C_{sp} \cdot A_{sp} \cdot (t_{sp1} - t_{sp2}) \quad (3)$$

$$Q_{sp} = C_{sp} \cdot A_{sp} \cdot (t_{sp1} - t_{sp2}) \quad (3)$$

where:

A_{sp} = surround panel area, m²,

t_{sp1} = area weighted room side surround panel surface temperature, °C, and

t_{sp2} = area weighted weather side surround panel surface temperature, °C.

NOTE 8—If a mean temperature correction for the surround panel is required, conduct calibration tests at three different mean temperature conditions as required in 5.1.2.6. The apparent thermal conductance of all of the rigid insulation foams used as the core of Calibration Transfer Standards and surround panels are a function of the mean temperature of that material. The mean temperature corrections for the Calibration Transfer Standard and the surround panel are previously established by measuring the apparent thermal conductance at three different mean temperature conditions as required in Annex A1, and Annex A11 of Test Method C 1363.

5.2.4.4 If

6.1.3.4 If $t_{b1} = t_h \pm 1^\circ\text{C}$ ($\pm 2^\circ\text{F}$) and $t_{b2} = t_c \pm 1^\circ\text{C}$ ($\pm 2^\circ\text{F}$) see 5.2.4.6 6.1.3.6 to determine the surface heat transfer coefficients. If calculated values of the surface temperatures are to be used in the calculation procedure specified in Section 89, Calculation of Standardized Thermal Transmittance, then also carry out the calculation procedures specified in 5.2.2.5 also should be carried out 6.1.3.7 to determine the convection coefficient, K_c .

5.2.4.5 If

6.1.3.5 If $t_{b1} > t_h + 1^\circ\text{C}$ (2°F) or $t_{b1} < t_h - 1^\circ\text{C}$ (2°F) and $t_{b2} > t_c + 1^\circ\text{C}$ (2°F) or $t_{b2} < t_c - 1^\circ\text{C}$ (2°F), after calculating t_1 and t_2 from Eq 17 and 18, respectively, see 5.2.4.7 1°C (2°F), see 6.1.3.7 to determine the surface heat transfer coefficients.

5.2.4.6

6.1.3.6 Surface heat transfer coefficients, h_h and h_c , when $t_{b1} = t_h \pm 1^\circ\text{C}$ ($\pm 2^\circ\text{F}$) and $t_{b2} = t_c \pm 1^\circ\text{C}$ ($\pm 2^\circ\text{F}$), are calculated as follows:

$$h_h = [Q_s / A_S (t_h - t_1)] \quad (4)$$

$$h_h = Q_s / (A_S \cdot (t_h - t_1)) \quad (4)$$

where:

t_h = average room side air temperature, °C, and

t_1 = equal area weighted average room side Calibration Transfer Standard surface temperature, °C, which is calculated from the following: equal area weighted average room side Calibration Transfer Standard surface temperature, °C. If the temperature sensors are located between the glazing and the core, the room side surface temperature is calculated as follows:

$$t_1 = t_1' + C_{ts} \cdot (t_1' - t_2) / C_g \quad (5)$$

where:

C_g = conductance of facing on calibration transfer standard, W/(m²•K):K).

NOTE 9—The 7—The apparent thermal conductance of the glazing layer is the thermal conductivity of the glazing material divided by the glazing layer thickness. A value of 1 W/(m•K)W/(m•K) for the thermal conductivity of float glass is recommended if the actual value is not provided by the manufacturer. In other cases, such as laminated or plastic glazing, the glazing manufacturer should provide the measured thermal conductivity of the glazing material.

$$h_c = Q_s / (A_S \cdot (t_2 - t_c)) \quad (6)$$

$$h_c = Q_s / (A_S \cdot (t_2 - t_c)) \quad (6)$$

where:

t_c = average weather side air temperature, °C, and