



**SLOVENSKI STANDARD**  
**oSIST prEN ISO 13000-2:2020**  
**01-september-2020**

---

**Polimerni materiali - Polizdelki iz politetrafluoroetilena (PTFE) - 2. del: Priprava preskušancev in ugotavljanje lastnosti (ISO/DIS 13000-2:2020)**

Plastics - Polytetrafluoroethylene (PTFE) semi-finished products - Part 2: Preparation of test specimens and determination of properties (ISO/DIS 13000-2:2020)

Kunststoffe - Polytetrafluorethylen (PTFE)-Halbzeuge - Teil 2: Herstellung von Probekörpern und Bestimmung von Eigenschaften (ISO/DIS 13000-2:2020)

Plastiques - Semi-produits en polytétrafluoroéthylène (PTFE) - Partie 2: Préparation des éprouvettes et détermination des propriétés (ISO/DIS 13000-2:2020)

<https://standards.iteh.ai/catalog/standards/sist/752c4892-d076-418b-90a9-874b88eadb7/osist-pr-en-iso-13000-2-2020>

**Ta slovenski standard je istoveten z: prEN ISO 13000-2**

---

**ICS:**

83.140.01	Izdelki iz gume in polimernih materialov na splošno	Rubber and plastics products in general
-----------	---	---

**oSIST prEN ISO 13000-2:2020**

**en,fr,de**

**iTeh STANDARD PREVIEW**  
**(standards.iteh.ai)**

[oSIST prEN ISO 13000-2:2020](https://standards.iteh.ai/catalog/standards/sist/752c4892-d076-418b-90a9-c874b88aadb7/osist-pren-iso-13000-2-2020)

<https://standards.iteh.ai/catalog/standards/sist/752c4892-d076-418b-90a9-c874b88aadb7/osist-pren-iso-13000-2-2020>

# DRAFT INTERNATIONAL STANDARD

## ISO/DIS 13000-2

ISO/TC 61/SC 9

Secretariat: KATS

Voting begins on:  
2020-07-03Voting terminates on:  
2020-09-25

---

---

## Plastics — Polytetrafluoroethylene (PTFE) semi-finished products —

### Part 2: Preparation of test specimens and determination of properties

*Plastiques — Semi-produits en polytétrafluoroéthylène (PTFE) —  
Partie 2: Préparation des éprouvettes et détermination des propriétés*

ICS: 83.140.01

**iTeh STANDARD PREVIEW**  
**(standards.iteh.ai)**

[oSIST prEN ISO 13000-2:2020](https://standards.iteh.ai/catalog/standards/sist/752c4892-d076-418b-90a9-c874b88aadb7/osist-pren-iso-13000-2-2020)  
<https://standards.iteh.ai/catalog/standards/sist/752c4892-d076-418b-90a9-c874b88aadb7/osist-pren-iso-13000-2-2020>

THIS DOCUMENT IS A DRAFT CIRCULATED FOR COMMENT AND APPROVAL. IT IS THEREFORE SUBJECT TO CHANGE AND MAY NOT BE REFERRED TO AS AN INTERNATIONAL STANDARD UNTIL PUBLISHED AS SUCH.

IN ADDITION TO THEIR EVALUATION AS BEING ACCEPTABLE FOR INDUSTRIAL, TECHNOLOGICAL, COMMERCIAL AND USER PURPOSES, DRAFT INTERNATIONAL STANDARDS MAY ON OCCASION HAVE TO BE CONSIDERED IN THE LIGHT OF THEIR POTENTIAL TO BECOME STANDARDS TO WHICH REFERENCE MAY BE MADE IN NATIONAL REGULATIONS.

RECIPIENTS OF THIS DRAFT ARE INVITED TO SUBMIT, WITH THEIR COMMENTS, NOTIFICATION OF ANY RELEVANT PATENT RIGHTS OF WHICH THEY ARE AWARE AND TO PROVIDE SUPPORTING DOCUMENTATION.

This document is circulated as received from the committee secretariat.

**ISO/CEN PARALLEL PROCESSING**



Reference number  
ISO/DIS 13000-2:2020(E)

© ISO 2020

## iTeh STANDARD PREVIEW (standards.iteh.ai)

[oSIST prEN ISO 13000-2:2020](https://standards.iteh.ai/catalog/standards/sist/752c4892-d076-418b-90a9-c874b88aadb7/osist-pren-iso-13000-2-2020)

<https://standards.iteh.ai/catalog/standards/sist/752c4892-d076-418b-90a9-c874b88aadb7/osist-pren-iso-13000-2-2020>



### **COPYRIGHT PROTECTED DOCUMENT**

© ISO 2020

All rights reserved. Unless otherwise specified, or required in the context of its implementation, no part of this publication may be reproduced or utilized otherwise in any form or by any means, electronic or mechanical, including photocopying, or posting on the internet or an intranet, without prior written permission. Permission can be requested from either ISO at the address below or ISO's member body in the country of the requester.

ISO copyright office  
CP 401 • Ch. de Blandonnet 8  
CH-1214 Vernier, Geneva  
Phone: +41 22 749 01 11  
Fax: +41 22 749 09 47  
Email: [copyright@iso.org](mailto:copyright@iso.org)  
Website: [www.iso.org](http://www.iso.org)

Published in Switzerland

# Contents

	Page
<b>Foreword</b> .....	<b>iv</b>
<b>1 Scope</b> .....	<b>1</b>
<b>2 Normative references</b> .....	<b>1</b>
<b>3 Terms and definitions</b> .....	<b>2</b>
<b>4 Sampling</b> .....	<b>2</b>
<b>5 Preparation of test specimens</b> .....	<b>2</b>
<b>6 Testing of semi-finished PTFE products</b> .....	<b>2</b>
6.1 General.....	2
6.2 Linear dimensions.....	2
6.3 Tensile properties.....	2
6.3.1 Tensile specimens.....	2
6.3.2 Procedure.....	6
6.4 Density.....	7
6.5 Loss in mass at 300 °C.....	7
6.6 Dimensional stability — General method.....	7
6.6.1 Apparatus.....	7
6.6.2 Test specimen.....	7
6.6.3 Procedure.....	8
6.6.4 Expression of results.....	8
6.7 Dimensional stability — Special method for the determination of the dimensional and the geometrical stability of thick-walled tubes.....	8
6.7.1 Apparatus.....	8
6.7.2 Test specimen.....	8
6.7.3 Procedure.....	8
6.7.4 Expression of results.....	9
6.8 Electrical properties.....	9
6.8.1 Dielectric strength (electric strength).....	9
6.9 Hardness.....	9
6.10 Colour.....	9
6.11 Resistance to environmental stress cracking (ESC).....	9
<b>Annex A (informative) Other standards relating to testing semi-finished products of PTFE</b> .....	<b>10</b>

## ISO/DIS 13000-2:2020(E)

## Foreword

ISO (the International Organization for Standardization) is a worldwide federation of national standards bodies (ISO member bodies). The work of preparing International Standards is normally carried out through ISO technical committees. Each member body interested in a subject for which a technical committee has been established has the right to be represented on that committee. International organizations, governmental and non-governmental, in liaison with ISO, also take part in the work. ISO collaborates closely with the International Electrotechnical Commission (IEC) on all matters of electrotechnical standardization.

International Standards are drafted in accordance with the rules given in the ISO/IEC Directives, Part 2.

The main task of technical committees is to prepare International Standards. Draft International Standards adopted by the technical committees are circulated to the member bodies for voting. Publication as an International Standard requires approval by at least 75 % of the member bodies casting a vote.

Attention is drawn to the possibility that some of the elements of this document may be the subject of patent rights. ISO shall not be held responsible for identifying any or all such patent rights.

ISO 13000-2 was prepared by Technical Committee ISO/TC 61, *Plastics*, Subcommittee SC 9, *Thermoplastic materials*.

This third edition cancels and replaces the second edition (ISO 13000-2: 2005), which has been technically revised.

ISO 13000 consists of the following parts, under the general title *Plastics — Polytetrafluoroethylene (PTFE) semi-finished products*:

- *Part 1: Requirements and designation* [oSIST prEN ISO 13000-2:2020](https://standards.iteh.ai/catalog/standards/sist/752c4892-d076-418b-90a9-c674b88aad67/osist-pr-en-iso-13000-2-2020)
- *Part 2: Preparation of test specimens and determination of properties* <https://standards.iteh.ai/catalog/standards/sist/752c4892-d076-418b-90a9-c674b88aad67/osist-pr-en-iso-13000-2-2020>

# Plastics — Polytetrafluoroethylene (PTFE) semi-finished products —

## Part 2:

# Preparation of test specimens and determination of properties

**WARNING** — Persons using this document should be familiar with normal laboratory practice, if applicable. This document does not purport to address all of the safety concerns, if any, associated with its use. It is the responsibility of the user to establish appropriate safety and health practices and to ensure compliance with any regulatory requirements.

## 1 Scope

This part of ISO 13000 specifies the preparation of test specimens and gives the test methods applicable to semi-finished products of polytetrafluoroethylene (PTFE).

## 2 Normative references

The following referenced documents are indispensable for the application of this document. For dated references, only the edition cited applies. For undated references, the latest edition of the referenced document (including any amendments) applies.

ISO 472, *Plastics — Vocabulary* <https://standards.iteh.ai/catalog/standards/sist/752c4892-d076-418b-90a9-c874b88aad7/osist-pre-iso-13000-2-2020>

ISO 527-2, *Plastics — Determination of tensile properties — Part 2: Test conditions for moulding and extrusion plastics*

ISO 527-3, *Plastics — Determination of tensile properties — Part 3: Test conditions for films and sheets*

ISO 868, *Plastics and ebonite — Determination of indentation hardness by means of a durometer (Shore hardness)*

ISO 1183 (all parts), *Plastics — Methods for determining the density of non-cellular plastics*

ISO 1923, *Cellular plastics and rubbers — Determination of linear dimensions*

ISO 2039-1, *Plastics — Determination of hardness — Part 1: Ball indentation method*

ISO 3611, *Geometrical product specifications (GPS) — Dimensional measuring equipment: Micrometers for external measurements — Design and metrological characteristics*

ISO 4599, *Plastics — Determination of resistance to environmental stress cracking (ESC) — Bent strip method*

ISO 4600, *Plastics — Determination of environmental stress cracking (ESC) — Ball or pin impression method*

ISO 13000-1, *Plastics — Polytetrafluoroethylene (PTFE) semi-finished products — Part 1: Requirements and designation*

IEC 60243-1, *Electrical strength of insulating materials — Part 1: Tests at power frequencies*

IEC 60243-2, *Electric strength of insulating materials — Part 2: Additional requirements for tests using direct voltage*

## ISO/DIS 13000-2:2020(E)

CIE PUBLICATION NO 15, *Colorimetry*

### 3 Terms and definitions

For the purposes of this part of ISO 13000, the terms and definitions given in ISO 472 and ISO 13000-1 apply.

ISO and IEC maintain terminological databases for use in standardization at the following addresses:

- ISO Online browsing platform: available at <https://www.iso.org/obp>
- IEC Electropedia: available at <http://www.electropedia.org/>

### 4 Sampling

Details of procedures for sampling semi-finished products depend to a large extent on the physical shape of the particular material. Whenever feasible, the materials shall be sampled. Sampling shall be statistically adequate to satisfy the requirements of the test method concerned.

### 5 Preparation of test specimens

The specimens used for testing shall be taken directly from or shall be machined from the semi-finished product without other treatment. Thus, conversion of a semi-finished product into a test specimen by any moulding procedure is not permitted. Where applicable, ISO standards shall be followed for the preparation of test specimens. In some instances, special procedures are required that are described either in the general discussion or in the method.

### 6 Testing of semi-finished PTFE products

oSIST prEN ISO 13000-2:2020  
<https://standards.iteh.ai/catalog/standards/sist/752c4892-d076-418b-90a9-c874b88aad7/osist-pren-iso-13000-2-2020>

#### 6.1 General

Properties required for specification purposes shall be determined in accordance with the International Standards referenced in this part of ISO 13000 or the procedures given in this part of ISO 13000. For the determination of density, tensile properties, hardness and electrical properties, condition the test specimens at 23 °C ± 2 °C for a period of at least 4 h prior to test. The other tests require no conditioning.

[Annex A](#) provides a list of other standards relating to testing semi-finished products of PTFE.

#### 6.2 Linear dimensions

These shall be determined by the procedures provided in ISO 1923 for cellular plastics.

#### 6.3 Tensile properties

##### 6.3.1 Tensile specimens

###### 6.3.1.1 General

The appropriate type of test specimen shall be chosen from those given in [6.3.1.2](#) to [6.3.1.5](#). At least three test specimens shall be prepared from the sample and three specimens shall be tested.

NOTE Test specimens prepared from moulded basic shapes, rods or tubes conforming to [6.3.1.2](#) are likely to give results similar to those obtained with test specimens prepared from the same product but conforming to [6.3.1.3](#).



When testing extruded products, the test specimens shall be cut parallel to the axis of extrusion so that, as far as possible, each test specimen represents a different section along the axis and a different area of the cross-section. When testing skived tape, skived sheet or skived film, the test specimens shall be cut perpendicular to the direction in which the pressure was applied when moulding the billet from which the product was skived. If this direction is not known, two sets of test specimens shall be prepared and tested, the test specimens in one set being cut at 90° to those in the other set and the mean result shall be calculated from the higher set of values (indicating, typically, the direction perpendicular to the axis of applied pressure). This procedure ensures a uniform way of reporting test results. The micro-tensile test specimen (see 6.3.1.3) is used most commonly for PTFE products.

### 6.3.1.2 Turned dumb-bell test specimens

The test specimens shall be turned so that their dimensions are in the ratios given in Figure 1, and so that the shape is as shown in Figure 1. The value of the larger diameter ( $D$ ) shall be 7 mm ± 0,5 mm, 10 mm ± 0,5 mm or 20 mm ± 0,5 mm.

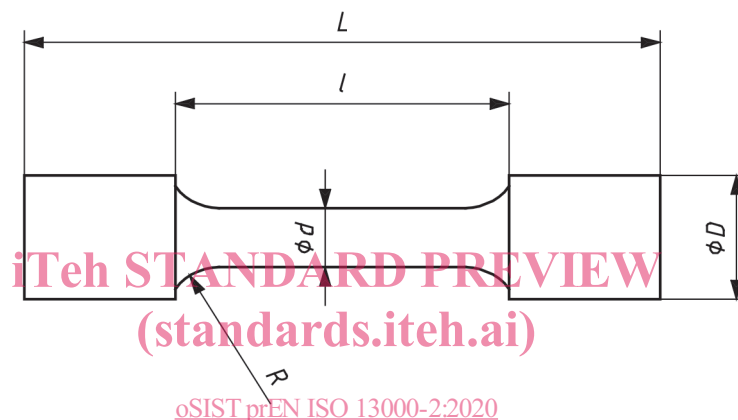

oSIST prEN ISO 13000-2:2020  
<https://standards.iteh.ai/catalog/standards/sist/752c4892-d076-418b-90a9-c874b88aad7/osist-pr-en-iso-13000-2-2020>

Ratios of dimensions of turned dumb-bell specimens:

$$d = 0,45D \text{ to } 0,55D$$

$$L = 5D \text{ to } 6D$$

$$l = 3D \text{ to } 3,5D$$

$$R = 0,2D \text{ to } 0,3D$$

Figure 1 — Turned dumb-bell specimen

### 6.3.1.3 Micro-tensile (small punched dumb-bell) test specimens

The sample shall be machined to produce a sheet or disc of thickness 1,5 mm to 2,5 mm, or turned to produce a rectangular-section ring which can be cut and flattened to give such a sheet. Test specimens conforming to the shape shown in Figure 2 and the dimensions given in Table 1 for micro-tensile specimens shall be punched from a sheet or disc using a single-stroke press and the appropriate knife-edged die. In any one test specimen, the thickness of the narrow, parallel-sided portion shall nowhere deviate by more than 2 % from the mean. The sheet shall be supported, while the test specimens are punched from it, on a slightly yielding material having a smooth surface (e.g. leather, rubber or high-quality cardboard) on a flat, rigid base. The cutting edge of the die shall be sharp and free from notches or other visual defects. In the case of thin sheet or skived tape of thickness from 0,125 mm to 3,0 mm, the test specimens shall be punched from the material "as-received".

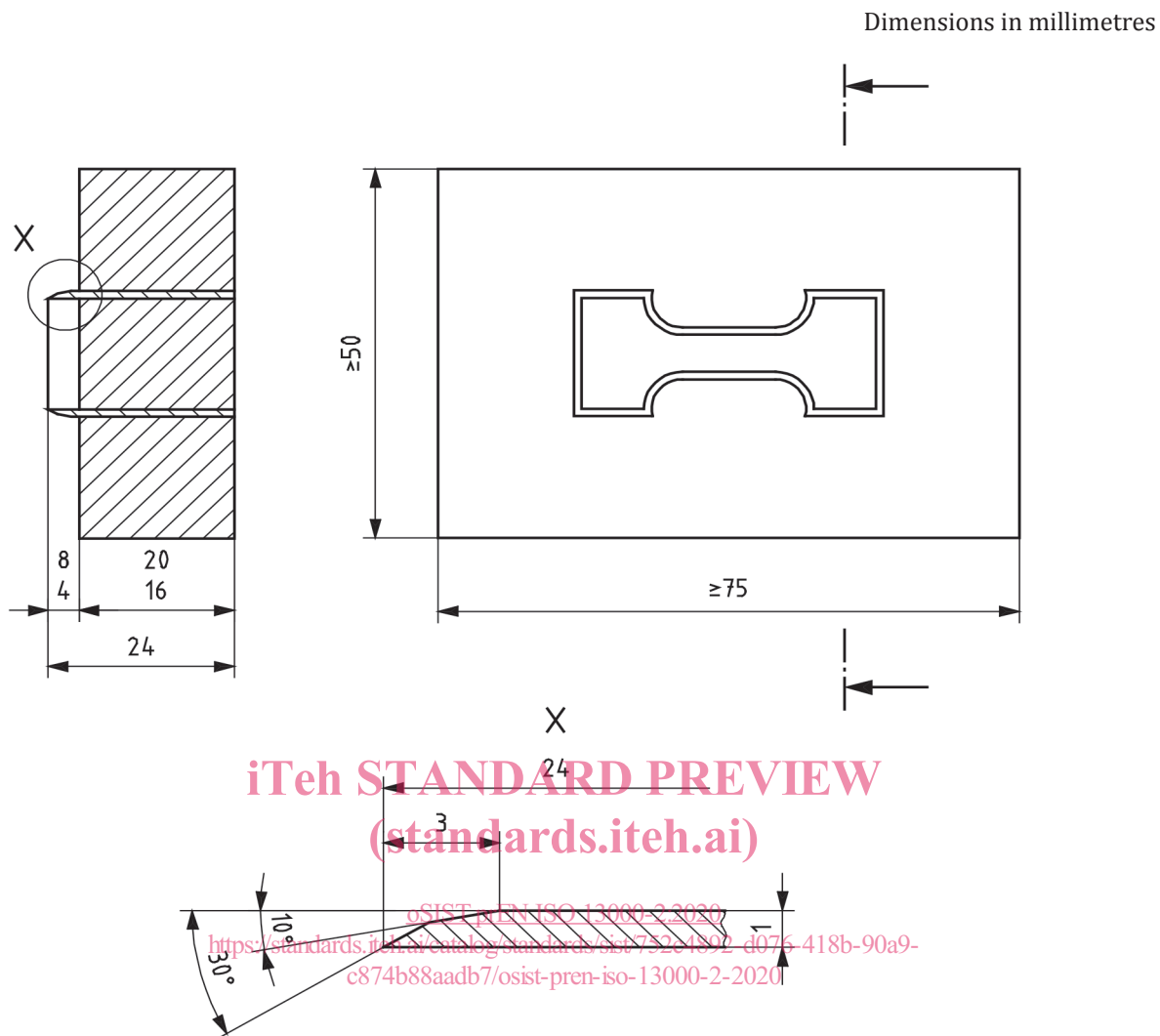

Inside dimensions of die are same as those of test specimen.

Rockwell C hardness of die: 45 to 50.

Die to be sharpened on outside of knife-edge only (as shown in figure).

**a) Steel-rule die**