



Designation: E 236 – 66 (Reapproved 1996)

AMERICAN SOCIETY FOR TESTING AND MATERIALS
100 Barr Harbor Dr., West Conshohocken, PA 19428
Reprinted from the Annual Book of ASTM Standards. Copyright ASTM

Standard Specification for Apparatus For Microdetermination Of Alkoxy Groups¹

This standard is issued under the fixed designation E 236; the number immediately following the designation indicates the year of original adoption or, in the case of revision, the year of last revision. A number in parentheses indicates the year of last reapproval. A superscript epsilon (ϵ) indicates an editorial change since the last revision or reapproval.

1. Scope

1.1 This specification covers apparatus for the microdetermination of methoxyl and ethoxyl groups in organic compounds.

NOTE 1—This specification was originally developed by the Committee on Microchemical Apparatus, Division of Analytical Chemistry, American Chemical Society.²

2. Reaction Flask

2.1 The reaction flask shall be of borosilicate glass and shall conform to the requirements of Fig. 1.

3. Condenser with Scrubber

3.1 The West-type condenser with scrubber shall be of borosilicate glass and conform to the requirements of Fig. 2.

NOTE 2—Spent scrubbing solution may be removed from the scrubber by inserting through the side arm of the scrubber a drawn-out medicine dropper or small rubber tube connected to a vacuum source.

NOTE 3—The scrubber is constricted to prevent scrubbing solution from being sucked back into the reaction flask or carried over into the receiver.

4. Delivery Tube

4.1 The delivery tube shall be of borosilicate glass and conform to the requirements of Fig. 3.

¹ This specification is under the jurisdiction of ASTM Committee E-41 on Laboratory Apparatus and is the direct responsibility of Subcommittee E41.07 on Piston Operated Volumetric Apparatus (POVA).

Current edition approved Sept. 20, 1966. Published November 1966. Originally published as E 236 – 1964 T. Last previous edition E 236– 55.

² Committee on Microchemical Analysis, Division of Analytical Chemistry, American Chemical Society. "Report on Recommended Specifications for Microchemical Apparatus, Alkoxy." *Analytical Chemistry*, Vol 28, 1956, p. 112.

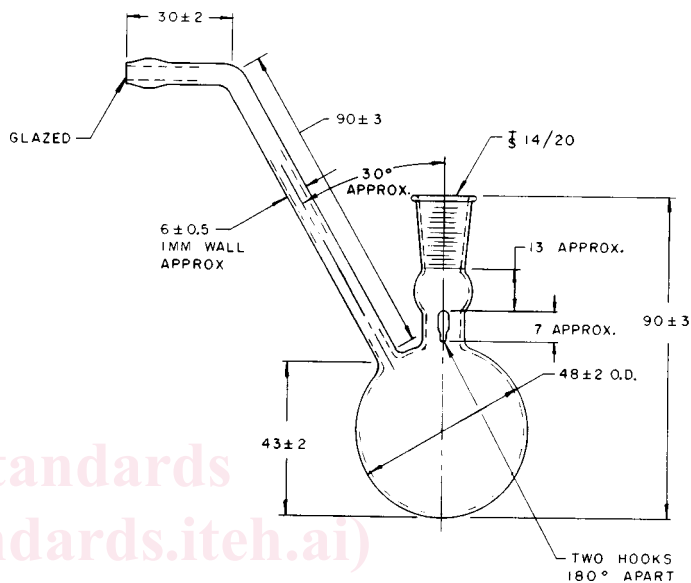

All dimensions are in millimetres.

FIG. 1 Reaction Flask

5. Receivers

5.1 Two types of receivers are specified, as follows:

5.1.1 *Receiver for Volumetric Analysis*³ shall be of borosilicate glass and conform to the requirements of Fig. 4.

5.1.2 *Receiver for Gravimetric Analysis* shall be of borosilicate glass and conform to the requirements of Fig. 5.

³ Used to establish the official A.O.A.C. microchemical method for alkoxy group determination, *Official Methods of Analysis*, 9th Ed., Association of Official Agricultural Chemists, Washington, DC, 1960, p. 646.

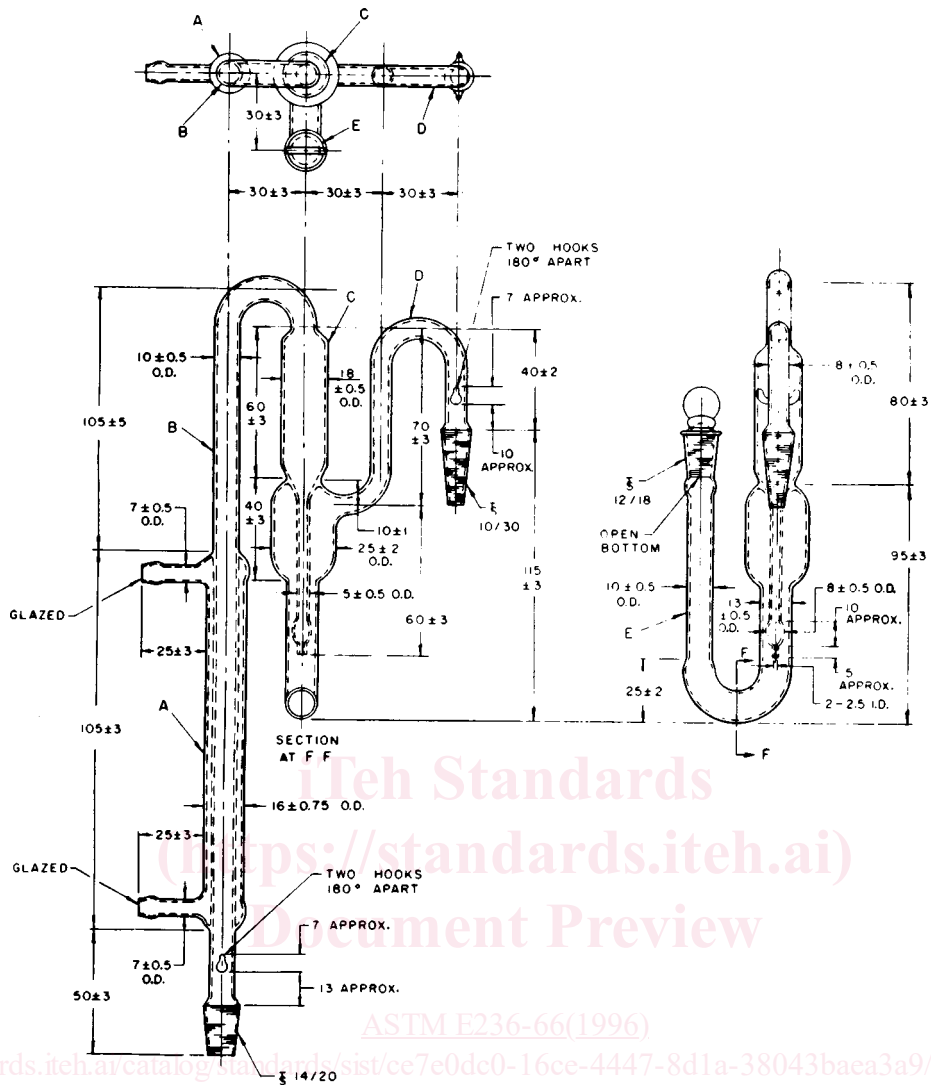

ASTM E236-66(1996)
 All dimensions are in millimetres.
FIG. 2 West-Type Condenser with Scrubber