**Industrial trucks — Verification of
stability —**

**Part 17:
Towing tractors, burden and
personnel carriers**

Chariots de manutention — Vérification de la stabilité —

Partie 17: Tracteurs, transporteurs de charges et de personnel

iteh Standards
(<https://standards.iteh.ai>)
Document Preview

[ISO 22915-17:2020](https://standards.iteh.ai/catalog/standards/iso/0a16340c-6c62-4db4-8cc4-41ac620bc0a7/iso-22915-17-2020)

<https://standards.iteh.ai/catalog/standards/iso/0a16340c-6c62-4db4-8cc4-41ac620bc0a7/iso-22915-17-2020>



iTeh Standards
(<https://standards.iteh.ai>)
Document Preview

[ISO 22915-17:2020](https://standards.iteh.ai/catalog/standards/iso/0a16340c-6c62-4db4-8cc4-41ac620bc0a7/iso-22915-17-2020)

<https://standards.iteh.ai/catalog/standards/iso/0a16340c-6c62-4db4-8cc4-41ac620bc0a7/iso-22915-17-2020>



COPYRIGHT PROTECTED DOCUMENT

© ISO 2020

All rights reserved. Unless otherwise specified, or required in the context of its implementation, no part of this publication may be reproduced or utilized otherwise in any form or by any means, electronic or mechanical, including photocopying, or posting on the internet or an intranet, without prior written permission. Permission can be requested from either ISO at the address below or ISO's member body in the country of the requester.

ISO copyright office
CP 401 • Ch. de Blandonnet 8
CH-1214 Vernier, Geneva
Phone: +41 22 749 01 11
Fax: +41 22 749 09 47
Email: copyright@iso.org
Website: www.iso.org

Published in Switzerland

Contents

	Page
Foreword	iv
1 Scope	1
2 Normative references	1
3 Terms and definitions	1
4 Test conditions	1
4.1 General	1
4.2 Operating conditions	1
4.3 Test load	2
4.3.1 General	2
4.3.2 Burden carriers	2
4.3.3 Personnel carriers	2
4.3.4 Steer and rear axles	3
4.3.5 Tests 1 and 2	3
4.3.6 Tests 3, 4, 5 and 6	3
5 Verification of stability	3
Bibliography	5

iTeh Standards
(<https://standards.iteh.ai>)
Document Preview

[ISO 22915-17:2020](https://standards.iteh.ai/catalog/standards/iso/0a16340c-6c62-4db4-8cc4-41ac620bc0a7/iso-22915-17-2020)

<https://standards.iteh.ai/catalog/standards/iso/0a16340c-6c62-4db4-8cc4-41ac620bc0a7/iso-22915-17-2020>

Foreword

ISO (the International Organization for Standardization) is a worldwide federation of national standards bodies (ISO member bodies). The work of preparing International Standards is normally carried out through ISO technical committees. Each member body interested in a subject for which a technical committee has been established has the right to be represented on that committee. International organizations, governmental and non-governmental, in liaison with ISO, also take part in the work. ISO collaborates closely with the International Electrotechnical Commission (IEC) on all matters of electrotechnical standardization.

The procedures used to develop this document and those intended for its further maintenance are described in the ISO/IEC Directives, Part 1. In particular, the different approval criteria needed for the different types of ISO documents should be noted. This document was drafted in accordance with the editorial rules of the ISO/IEC Directives, Part 2 (see www.iso.org/directives).

Attention is drawn to the possibility that some of the elements of this document may be the subject of patent rights. ISO shall not be held responsible for identifying any or all such patent rights. Details of any patent rights identified during the development of the document will be in the Introduction and/or on the ISO list of patent declarations received (see www.iso.org/patents).

Any trade name used in this document is information given for the convenience of users and does not constitute an endorsement.

For an explanation of the voluntary nature of standards, the meaning of ISO specific terms and expressions related to conformity assessment, as well as information about ISO's adherence to the World Trade Organization (WTO) principles in the Technical Barriers to Trade (TBT), see www.iso.org/iso/foreword.html.

This document was prepared by Technical Committee ISO/TC 110, *Industrial trucks*, Subcommittee SC 2 *Safety of powered industrial trucks*.

Any feedback or questions on this document should be directed to the user's national standards body. A complete listing of these bodies can be found at www.iso.org/members.html.

A list of all parts in the ISO 22915 series can be found on the ISO website.

Industrial trucks — Verification of stability —

Part 17:

Towing tractors, burden and personnel carriers

1 Scope

This document specifies the tests for verifying the stability of towing tractors, burden and personnel carriers as defined in ISO 5053-1.

2 Normative references

The following documents are referred to in the text in such a way that some or all of their content constitutes requirements of this document. For dated references, only the edition cited applies. For undated references, the latest edition of the referenced document (including any amendments) applies.

ISO 22915-1, *Industrial trucks — Verification of stability — Part 1: General*

ISO 3411:2007, *Earth-moving machinery — Physical dimensions of operators and minimum operator space envelope*

ISO 5053-1, *Industrial trucks — Terminology and classification — Part 1: Types of industrial trucks*

ISO 5353:1995, *Earth-moving machinery, and tractors and machinery for agriculture and forestry — Seat index point*

3 Terms and definitions

[ISO 22915-17:2020](https://standards.iteh.ai/catalog/standards/iso/0a16340c-6c62-4db4-8cc4-41ac620bc0a7/iso-22915-17-2020)

<https://standards.iteh.ai/catalog/standards/iso/0a16340c-6c62-4db4-8cc4-41ac620bc0a7/iso-22915-17-2020>

For the purposes of this document, the terms and definitions given in ISO 5053-1 and ISO 22915-1 apply.

ISO and IEC maintain terminological databases for use in standardization at the following addresses:

- ISO Online Browsing Platform: available at <https://www.iso.org/obp>
- IEC Electropedia: available at <http://www.electropedia.org/>

4 Test conditions

4.1 General

The requirements of ISO 22915-1 shall apply.

If the truck can travel with an elevating operator position, an additional test shall be performed at the maximum height. If a device automatically limits the travel speed, this reduced speed shall be used when determining the angle of the tilt table.

4.2 Operating conditions

In addition to the requirements of ISO 22915-1, the truck to be tested shall reflect its operating weight and shall include all options and accessory items approved by the truck manufacturer which, when installed, will decrease the stability of the truck.

4.3 Test load

4.3.1 General

The test load for carriers shall consist of a load corresponding to 4.3.2 or 4.3.3.

Towing tractors with a load platform shall be tested according to the method as defined for burden carriers (see 4.3.2).

4.3.2 Burden carriers

The test load shall be placed on the load bed of the carrier and secured such that the centre of gravity, G, is directly above the geometric centreline of the load bed.

The minimum height of the centre of gravity, G, shall be 600 mm above the load bed (see Figure 1) or as defined by the manufacturer.

The centre of gravity, G, defined by the manufacturer shall be indicated on the information plate.

The longitudinal position of the centre of gravity, G, shall be half of the length of the load bed.

Dimensions in millimetres

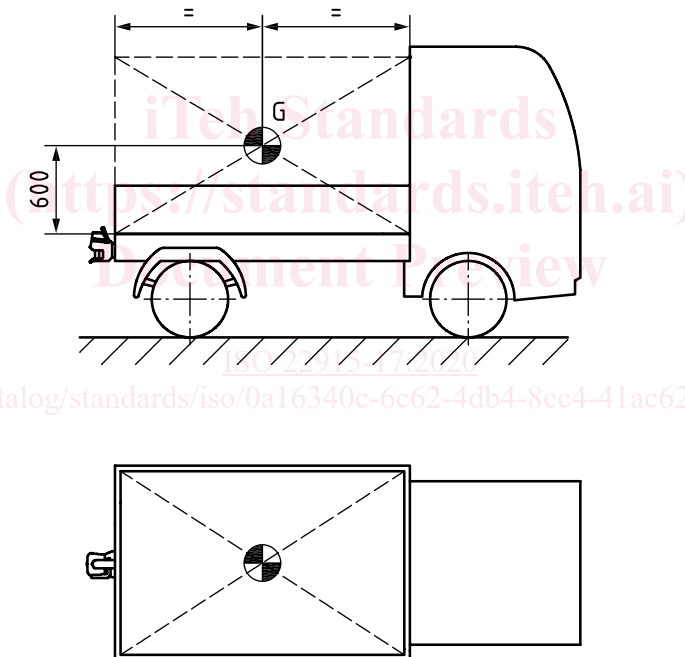

Figure 1 — Indication of the minimum height of the centre of gravity, G

Manufacturers may define a load distribution plan to allow various combinations of load and load position on the load bed. The requirement above includes all tests that are necessary to verify the stability for each defined load arrangement.

4.3.3 Personnel carriers

Personnel carriers shall be tested in the conditions of least stability with respect to the number and location of passengers. If provided, seats shall be adjusted to the mid-point adjustment position of seats in each test.

Each passenger shall be simulated by an object having a mass of 114,1 kg corresponding to a large size operator, in accordance with ISO 3411:2007, Clause 4. Objects simulating passengers and operator shall be secured to their respective position or seats.