



## Standard Specification for Austempered Ductile Iron Castings [Metric]<sup>1</sup>

This standard is issued under the fixed designation A 897M; the number immediately following the designation indicates the year of original adoption or, in the case of revision, the year of last revision. A number in parentheses indicates the year of last reapproval. A superscript epsilon ( $\epsilon$ ) indicates an editorial change since the last revision or reapproval.

### 1. Scope

1.1 This specification covers ductile iron castings that are subsequently heat treated by an austempering process as defined in 8.1.

1.2 The application of the austempering heat treatment extends the range of properties achievable in ductile iron castings.

1.3 No precise quantitative relationship can be stated between the properties of the iron in various locations of the same casting or between the properties of castings and those of a test specimen cast from the same iron (see Appendix X1). However, austempering heat treatment will tend to diminish any differences in mechanical properties.

1.4 The production of castings, machining (if required), and the austempering heat treatments may be performed by different manufacturers, as covered in Section 13. The purchaser should establish by contract agreement, at the time of ordering, the responsibility of the various parties for meeting the specification requirements.

1.5 The values in this specification are stated in SI units.

NOTE 1—A companion specification, A 897, has been developed in which the values are stated in inch-pound units. Each specification is independent and the mathematical conversions are not exact equivalents.

### 2. Referenced Documents

#### 2.1 ASTM Standards:

A 370 Test Methods and Definitions for Mechanical Testing of Steel Products<sup>2</sup>

A 732M Specification for Castings, Investment, Carbon and Low Alloy Steel for General Application, and Cobalt Alloy for High Strength at Elevated Temperatures (Metric)<sup>3</sup>

A 834 Specification for Common Requirements for Iron Castings for General Industrial Use<sup>3</sup>

E 8M Test Methods for Tension Testing of Metallic Materials (Metric)<sup>4</sup>

E 23 Test Methods for Notched Bar Impact Testing of Metallic Materials<sup>4</sup>

<sup>1</sup> This specification is under the jurisdiction of ASTM Committee A-4 on Iron Castings and is the direct responsibility of Subcommittee A04.02 on Malleable and Ductile Iron Castings.

Current edition approved March 30, 1990. Published July 1990.

<sup>2</sup> Annual Book of ASTM Standards, Vol 01.03.

<sup>3</sup> Annual Book of ASTM Standards, Vol 01.02.

<sup>4</sup> Annual Book of ASTM Standards, Vol 03.01.

#### 2.2 Military Standard:

MIL-STD-129 Marking for Shipment and Storage<sup>5</sup>

### 3. Ordering Information

3.1 Orders for material to this specification shall include the following information:

3.1.1 ASTM designation, with year of issue,

3.1.2 Grade of austempered ductile iron required (see Table 1 and Sections 5 and 6),

3.1.3 Chemical composition requirements, if any (see Section 4),

3.1.4 Heat treated microstructure restrictions (see Section 8),

3.1.5 Test coupon criteria (see Section 10),

3.1.6 Lot size and tests per lot (see 10.6 and Section 13),

3.1.7 Special requirements, if desired, including hardness, radiographic soundness, magnetic particle inspection, pressure tightness, dimensions, or surface finish (see Section 7),

3.1.8 Certification, if required (see Section 14),

3.1.9 Special preparation for delivery, if required (see Section 15).

### 4. Chemical Composition

4.1 Although this specification has no specific chemical requirements, such requirements may be agreed upon between the manufacturer and the purchaser.

### 5. Mechanical Properties

5.1 Tensile property requirements include tensile strength, yield strength, and elongation and apply only after austempering heat treatment.

5.2 The iron represented by the test specimens shall conform to the requirements as presented in Table 1.

5.3 The yield strength shall be determined by the 0.2 % offset method (see Test Methods E 8M).

### 6. Impact Requirements

6.1 The iron represented by the test specimens shall conform to the impact properties presented in Table 1.

6.2 Impact energy requirements apply only after test material has been austempered. The impact test specimens must be finish ground to required dimensions after heat treatment.

<sup>5</sup> Available from Standardization Documents, Order Desk, Building 4, Section D, 700 Robbins Ave., Philadelphia, PA 19111-5094, Attn: NPODS.

TABLE 1 Mechanical Property Requirements of Grades

	Grade 850/550/10	Grade 1050/700/7	Grade 1200/850/4	Grade 1400/1100/1	Grade 1600/1300/-
Tensile strength, min, MPa	850	1050	1200	1400	1600
Yield strength, min, MPa	550	700	850	1100	1300
Elongation in 50 mm, min, %	10	7	4	1	... <sup>A</sup>
Impact energy, J <sup>B</sup>	100	80	60	35	... <sup>A</sup>
Typical hardness, BHN, kg/mm <sup>2C</sup>	269-321	302-363	341-444	388-477	444-555

<sup>A</sup> Elongation and impact requirements are not specified. Although Grades 1400/1100/1 and 1600/1300/- are both primarily used for gear and wear resistance applications, Grade 1400/1100/1 has applications where some sacrifice in wear resistance is acceptable in order to provide a limited amount of ductility and impact resistance.

<sup>B</sup> Unnotched charpy bars tested at 22 ± 4°C. The values in the table are a minimum for the average of the highest three test values of the four tested samples.

<sup>C</sup> Hardness is not mandatory and is shown for information only.

7. Special Requirements

7.1 When specified in the contract or purchase order, castings shall meet special requirements as to hardness, chemical composition, microstructure, pressure tightness, radiographic soundness, magnetic particle inspection, dimensions, and surface finish. Refer to Specification A 834 for a list of common requirements for iron castings not specifically referenced elsewhere in this specification.

7.2 When specified in the contract or purchase order, castings shall meet special requirements prior to the austempering heat treatment operation.

8. Heat Treatment

8.1 Castings produced in accordance with this specification shall be heat treated by an austempering process consisting of heating the castings to a fully austenitic, homogeneous condition, cooling (at a rate usually sufficient to avoid the formation of pearlite) to a temperature above the martensite start temperature, and isothermally transforming the matrix structure for a time sufficient to produce the desired properties. This process shall produce a microstructure that is substantially acicular ferrite and austenite.

8.2 The cooling rate within some sections may not be sufficient to avoid the formation of pearlite or other high temperature transformation products. In such cases, the maximum acceptable quantities of these microconstituents and the location(s) within the casting may be established by agreement between the manufacturer and the purchaser.

8.3 Martensite may be present in the microstructure of Grade 1600/1300/-. Acceptable quantities of martensite may be established by agreement between the manufacturer and the purchaser.

8.4 The manufacturer and the purchaser may agree upon special chemical compositions or processing requirements to limit the microconstituents described in 8.2 and 8.3.

8.5 Upon agreement between the manufacturer and the purchaser, tension test specimens described in Section 12 may be machined prior to the austempering heat treatment. In this case, heat treatment shall be performed in an inert or carbon controlled environment so as to prevent carburization, decarburization, or scaling. Handling and fixturing must be such as to prevent test bar distortion (see X1.4).

9. Workmanship, Finish, and Appearance

9.1 The surfaces of castings shall be clean and free of adhering molding material, heat treatment oils or salts, cracks,

hot tears, or other injurious defects such as slag and surface porosity. Dimensions shall conform to drawings or patterns supplied by the purchaser.

9.2 Castings shall not have chilled corners or center chill in areas to be machined.

10. Test Coupons

10.1 Separately cast test coupons from which the tension test and charpy test specimens are machined shall be cast to the size and shape shown in Fig. 1 or Fig. 2. A modified keel block cast from the mold shown in Fig. 3 may be substituted for the 25-mm Y-block or the 25-mm keel block. The test coupons shall be cast in open molds made of suitable core sand having a minimum wall thickness of 38 mm for the 13-mm and 25-mm sizes and 76 mm for the 76-mm size. The coupons shall be left in the mold until they have cooled to a black color (480°C or less). The size and type of coupon cast to represent the casting shall be at the option of the purchaser. In case no option is expressed, the manufacturer shall make the choice.

10.2 When investment castings are made in accordance with this specification, the manufacturer may use cast-to-size test specimens that are either incorporated in the mold with the castings or separately cast using the same type of mold and the same thermal conditions that are used to produce the castings. The test specimens shall be made to the dimensions shown in

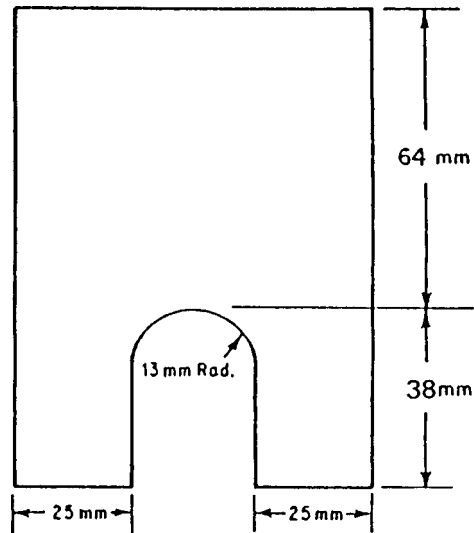

NOTE—The length of the keel block shall be 150 mm.

FIG. 1 Keel Block for Test Coupons

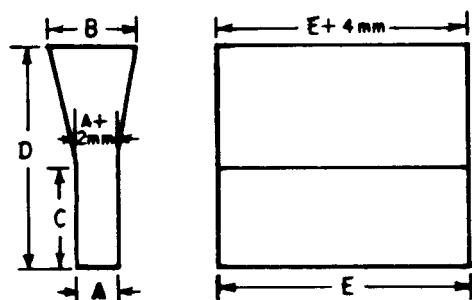

Dimensions	"Y" Block Size		
	For Castings of Thickness Less Than 13 mm	For Castings of Thickness 13 mm to 38 mm	For Castings of Thickness of 38 mm and Over
	mm	mm	mm
A	13	25	75
B	40	55	125
C	50	75	100
D	100	150	200
E	175	175	175
	approx	approx	approx

FIG. 2 Y-Blocks for Test Coupons

Fig. 1 of Specification A 732M or Fig. 4 of Test Methods and Definitions A 370. The exact procedure to be used for producing test specimens shall be agreed upon by the manufacturer and the purchaser.

10.3 When castings made in accordance with this specification are produced by nodularization directly in the mold, the manufacturer may use either separately cast test coupons or test specimens cut from castings. If test bars are to be cut from castings, test bar location shall be agreed upon by the purchaser and the manufacturer and indicated on the casting drawing. When separately cast test coupons are used, selection shall be as outlined in 10.1 and shown in Figs. 1-6. Appendix X2 provides guidelines for selection of coupons with mold cooling rates representative of various casting sections.

10.4 Test coupons shall be poured from the same ladle or heat as the castings they represent and, unless otherwise agreed upon by the manufacturer and the purchaser, shall be subject to the same post inoculation and alloying practice.

10.5 Test coupons shall be heat treated with the castings they represent.

10.6 The number of test coupons and the number of tests required per order or lot size shall be established at the time of ordering. This agreement should include a definition of lot size. Lot size can be defined to include the entire order, a specified portion of that order, a specified manufacturing production period, or a specified quantity of parts shipped to the purchaser.

10.7 If any test specimen shows obvious defects, another may be cut from the same test block or from another test block representing the same metal. Positions other than "A" or "B" in Fig. 4 shall not be used. In those cases where removal of test bars from actual castings has been agreed upon (see 10.2 and 10.3), a second test bar may be obtained from an alternate location of equivalent section or from a second casting processed in the same lot.

11. Tension Test Specimens

11.1 The standard round tension test specimen with a

50-mm gage length shown in Fig. 5 shall be used, except when the 13-mm Y-block coupon is used. In this case, either of the test specimens shown in Fig. 6 shall be satisfactory. Tension test specimens shall be machined only from Positions A (preferred) or B in Fig. 4. The test bars may be machined before or after heat treatment in accordance with 8.5.

12. Impact Test Specimens

12.1 The unnotched Charpy impact strength shall be determined according to Test Methods E 23 with the following variations: Specimens are to be prepared unnotched to dimensions in Fig. 9 of Test Methods E 23. Blanks from which test specimens are machined shall be cut only from Positions A or B in Fig. 4. Test temperature shall be  $22 \pm 4^\circ\text{C}$ . Four specimens shall be tested, with the lowest impact energy value discarded and the remaining three values averaged. The average impact energy shall meet the requirement of Table 1.

13. Responsibility for Quality and Inspection

13.1 At the time of an order, the purchaser should establish an agreement for quality and inspection requirements with the manufacturers. The form of this agreement depends upon which of the conditions in 13.2, 13.3, or 13.4 are determined to exist.

13.2 If all manufacturing operations are performed by a single manufacturer, that manufacturer is responsible for performance of all quality and inspection requirements covered herein.

13.3 If, at the time of ordering, the purchaser determines that more than one manufacturer will contribute to the casting, machining, and heat treatment operations, in any sequential fashion, an agreement should be negotiated that defines and assigns individual responsibility for each specific quality and inspection requirement. This does not prevent an agreement wherein any one manufacturer in the chain of sequential operations can agree to assume full responsibility for all quality and inspection requirements.

13.4 To avoid future disputes, the purchaser can require that all companies in the manufacturing chain be identified. Changes shall not be made without approval of the purchaser. The manufacturer(s) may require the purchaser to provide written agreement for any changes mutually agreed upon.

13.5 Unless specified to the contrary by the purchaser, any of the manufacturers in the chain may use his or her own or any other facilities for performance of the inspection requirements. Responsibility for meeting the specified properties remains with the parties defined in 13.2 or 13.3. This shall not prevent the purchaser from also performing any or all of the quality and inspection requirements.

14. Certification

14.1 Where required by contract, the manufacturer's certification shall be furnished to the purchaser stating that the material was manufactured, sampled, tested, and inspected in accordance with the material specification and was found to meet the requirements. The certification shall include the results of all tests performed.

15. Preparation for Delivery

15.1 Unless otherwise specified in the contract or purchase