



Designation: E 259 – 98

AMERICAN SOCIETY FOR TESTING AND MATERIALS
100 Barr Harbor Dr., West Conshohocken, PA 19428
Reprinted from the Annual Book of ASTM Standards. Copyright ASTM

Standard Practice for Preparation of Pressed Powder White Reflectance Factor Transfer Standards for Hemispherical and Bi-Directional Geometries¹

This standard is issued under the fixed designation E 259; the number immediately following the designation indicates the year of original adoption or, in the case of revision, the year of last revision. A number in parentheses indicates the year of last reapproval. A superscript epsilon (ϵ) indicates an editorial change since the last revision or reapproval.

INTRODUCTION

The internationally accepted standard of reflectance is the perfect reflecting diffuser. This ideal reflecting surface reflects 100 % of the incident radiant power such that the radiance is the same for all directions within the hemisphere above the surface. No physical realization of this standard exists. Optical properties of standards prepared from pressed plaques of magnesium carbonate (MgCO_3), barium sulfate (BaSO_4), or polytetrafluoroethylene (PTFE) can approximate an ideal standard. For further information see CIE Publication No. 46 (1).² The principal use of a white reflectance factor standard is to transfer an absolute scale of reflectance to a more durable material or from one instrument to another. In theory, it should be easy to do this transfer from first principles. In practice, one is likely to need values for parameters that are unknown, proprietary, or require a high level of skill. Some, but not all, of those parameters are discussed in this practice.

1. Scope

1.1 This practice covers procedures for preparing pressed powder transfer standards. These standards can be used in the near-ultraviolet, visible and near-infrared region of the electromagnetic spectrum. Procedures for calibrating the reflectance factor of materials on an absolute basis are contained in CIE Publication No. 44 (2). Pressed powder standards are used as transfer standards for such calibrations because they have a high reflectance factor that is nearly constant with wavelength, and because the geometric distribution of reflected flux resembles that from the perfect reflecting diffuser.

1.2 The values stated in SI units are to be regarded as the standard. The values in parentheses are for information only.

1.3 *This standard does not purport to address all of the safety concerns, if any, associated with its use. It is the responsibility of the user of this standard to establish appropriate safety and health practices and determine the applicability of regulatory limitations prior to use.*

¹ This practice is under the jurisdiction of ASTM Committee E-12 on Color and Appearance and is the direct responsibility of Subcommittee E12.02 on Spectrophotometry and Colorimetry.

Current edition approved Oct. 10, 1998. Published March 1999. Originally published as E 259 – 65. Last previous edition E 259 – 97.

² The boldface numbers in parentheses refer to the list of references at the end of this practice.

2. Referenced Documents

2.1 *ASTM Standards:*
E 284 Terminology of Appearance³

3. Terminology

3.1 Terms and definitions in Terminology E 284 are applicable to this practice.

3.2 *Definitions*—The following definitions are particularly important to this practice:

3.2.1 *perfect reflecting diffuser*—ideal reflecting surface that neither absorbs nor transmits light, but reflects diffusely, with the radiance of the reflecting surface being the same for all reflecting angles, regardless of the angular distribution of the incident light. (1990)

3.2.2 *reflectance, ρ , n* —ratio of the reflected radiant or luminous flux to the incident flux in the given conditions. [CIE]^A

3.2.3 The term *reflectance* is often used in a general sense or as an abbreviation for *reflectance factor*. Such usage may be assumed unless the above definition is specifically required by the context. (1989b)

3.2.4 *reflectance factor, R , n* —ratio of the flux reflected from the specimen to the flux reflected from the perfect reflecting diffuser under the same geometric and spectral conditions of measurement. [CIE]^B(1988)

4. Summary of Practice

4.1 Procedures are given for the preparation of white

³ *Annual Book of ASTM Standards*, Vol 06.01.

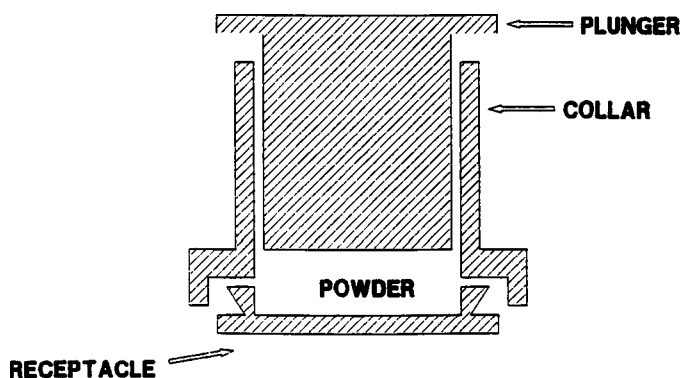

NOTE 1—The collar and receptacle should be securely held in place before pressing the powder.

FIG. 1 Example Powder Press

reference standards of diffuse reflectance factor and diffuse radiance factor. The recommended materials are white powders that are pressed into plaques. These plaques provide close approximations to the optical properties of the perfect reflecting diffuser, and may be used to transfer a scale of absolute reflectance to another material or to an instrument.

5. Significance and Use

5.1 All commercial reflectometers measure relative reflectance. The instrument reading is the reflectance factor, the ratio of the light reflected by a reference specimen to that reflected by a test specimen. That ratio is dependent on specific instrument parameters.

5.2 National standardizing laboratories and some research laboratories measure reflectance on instruments calibrated from basic principles, thereby establishing a scale of absolute reflectance as described in CIE Publication No. 44 (2). These measurements are sufficiently difficult that they are usually left to laboratories that specialize in them.

5.3 A standard that has been measured on an absolute scale could be used to transfer that scale to a reflectometer. While such procedures exist, the constraints placed on the mechanical properties restrict the suitability of some optical properties, especially those properties related to the geometric distribution of the reflected light. Thus, reflectance factor standards which are sufficiently rugged and able to be cleaned, depart considerably from the perfect diffuser in the geometric distribution of reflected radiance.

5.4 The geometric distribution of reflected radiance from a pressed powder plaque is sufficiently diffuse to provide a dependable calibration of a directional-hemispherical reflectometer. Although pressed powder standards are subject to contamination and breakage, the directional-hemispherical reflectance factor of pressed powder standards can be sufficiently reproducible from specimen to specimen made from a given lot of powder, so as to allow one to assign absolute reflectance factor values to all the powder in a lot.

5.5 This practice describes how to prepare white reflectance factor standards from a powder in a manner that allows a standardizing laboratory to assign the absolute scale of reflectance to the plaque.

6. Apparatus

6.1 The basic apparatus for producing a pressed powder standard includes a powder press, powder containers and a balance. There are presently two commercial suppliers of powder presses.⁴ The press and receptacles can also be made in a local machine shop. A suggested configuration is shown in Fig. 1. The optical surface of the plaque should be pressed against a surface of ground glass or poly(methyl methacrylate) to provide a matte finish on the pressed plaque. Powder receptacles should be at least 5 mm deep for BaSO₄ and at least 10 mm deep for PTFE.

7. Reagents and Materials

7.1 *Barium Sulfate*—the barium sulfate should be of the highest purity. It should be specially refined for optical and spectroscopic use (3).

7.2 *Polytetrafluoroethylene*—the PTFE (4) should also be specially refined for optical and spectroscopic use but some commercial grades have been found to be acceptable substitutes. (5) There is currently no commercial source for small quantities of optical grade PTFE powder. Large quantities (drums) of commercial grade PTFE can be obtained from manufacturers.

8. Procedure

8.1 Store all powdered reflectance standards in tightly capped glass containers. If the powder is purchased in plastic containers, transfer it to a glass container as soon as possible. Before using the powder, place it in a glass blender equipped with stainless-steel or PTFE-coated blades and pulverize to a uniform consistency. Transfer the quantity of powder to be used with stainless steel or PTFE-coated spoons. Perform the whole operation in a draft-free location, away from sources of small particulate contamination, filters, sweaters, windows, ovens, etc. Perform all measurements (weight, height, width, depth, volume, area, etc.) with adequate precision to ensure that the final density is within 5 % of the specified value. The most reproducible standards are made by pressing the powder to a specific density. Thus, determine the mass of the powder to be used from the volume of the receptacle.

8.2 *Barium Sulfate*—Press BaSO₄ to a density of 2000 kg/m³ (2.0 gm/cm³) and a thickness of at least 5 mm. Press several specimens in succession. Select matched pairs to be representative of the contents of the bottle of powder. Keep the pressed plaques in a covered desiccator when not in use. Some suppliers of BaSO₄ provide calibration values with each bottle of powder, other suppliers provide only 3 or 4 quality reference checks and a reference to published values of reference standards prepared from the powder. Table 1 gives the 6°/diffuse reflectance factor values for Eastman White Reflectance Standard (3).

8.2.1 Another description of this procedure is found in Ref. (4).

⁴ Powder press conforming to ISO 2469 and DIN 5033 is available from Carl Zeiss Canada, Ltd., 45 Valleybrook Drive, Don Mills, Ontario M3B-2S6, Canada, Part Number 505866; and Technidyne Corporation, 100 Quality Avenue, New Albany, IN 47150-2272, Part Number 176601.