



**SLOVENSKI STANDARD**  
**SIST EN 16416:2023**

**01-april-2023**

---

**Geosintetične glinene pregrade - Ugotavljanje indeksa vodnega pretoka - Metoda s permeametro (merilnikom prepustnosti) z gibko steno pri konstantnem vodnem tlaku**

Geosynthetic clay barriers - Determination of water flux index - Flexible wall permeameter method at constant head

Geosynthetische Tondichtungsbahnen - Bestimmung der Durchflussrate - Triaxialzellen-Methode mit konstanter Druckhöhe

Barrières géosynthétiques argileuses - Détermination de l'indice eau par analyse en flux - Méthode au perméamètre à paroi flexible de charge constante

**Ta slovenski standard je istoveten z: EN 16416:2023**

---

**ICS:**

59.080.70	Geotekstilije	Geotextiles
91.100.50	Veziva. Tesnilni materiali	Binders. Sealing materials

**SIST EN 16416:2023** en



EUROPEAN STANDARD

EN 16416

NORME EUROPÉENNE

EUROPÄISCHE NORM

February 2023

ICS 59.080.70; 91.100.50

Supersedes EN 16416:2013

English Version

## Geosynthetic clay barriers - Determination of water flux index - Flexible wall permeameter method at constant head

Barrières géosynthétiques argileuses - Détermination de l'indice eau par analyse en flux - Méthode au perméamètre à paroi flexible de charge constante

Geosynthetische Tondichtungsbahnen - Bestimmung der Durchflussrate - Triaxialzellen-Methode mit konstanter Druckhöhe

This European Standard was approved by CEN on 25 December 2022.

CEN members are bound to comply with the CEN/CENELEC Internal Regulations which stipulate the conditions for giving this European Standard the status of a national standard without any alteration. Up-to-date lists and bibliographical references concerning such national standards may be obtained on application to the CEN-CENELEC Management Centre or to any CEN member.

This European Standard exists in three official versions (English, French, German). A version in any other language made by translation under the responsibility of a CEN member into its own language and notified to the CEN-CENELEC Management Centre has the same status as the official versions.

CEN members are the national standards bodies of Austria, Belgium, Bulgaria, Croatia, Cyprus, Czech Republic, Denmark, Estonia, Finland, France, Germany, Greece, Hungary, Iceland, Ireland, Italy, Latvia, Lithuania, Luxembourg, Malta, Netherlands, Norway, Poland, Portugal, Republic of North Macedonia, Romania, Serbia, Slovakia, Slovenia, Spain, Sweden, Switzerland, Türkiye and United Kingdom.



EUROPEAN COMMITTEE FOR STANDARDIZATION  
COMITÉ EUROPÉEN DE NORMALISATION  
EUROPÄISCHES KOMITEE FÜR NORMUNG

CEN-CENELEC Management Centre: Rue de la Science 23, B-1040 Brussels

<b>Contents</b>	<b>Page</b>
European foreword .....	3
<b>1</b> Scope.....	<b>4</b>
<b>2</b> Normative references.....	<b>4</b>
<b>3</b> Terms and definitions.....	<b>4</b>
<b>4</b> Apparatus .....	<b>4</b>
<b>5</b> Permeant water.....	<b>9</b>
<b>6</b> Specimen sampling and preparation.....	<b>9</b>
<b>7</b> Procedure .....	<b>9</b>
<b>8</b> Calculation.....	<b>11</b>
<b>9</b> Test report.....	<b>11</b>
Annex A (informative) Hydraulic conductivity calculation .....	12
Annex B (informative) Permittivity calculation .....	13
Bibliography .....	14

(standards.iteh.ai)

SIST EN 16416:2023

<https://standards.iteh.ai/catalog/standards/sist/582a57de-26c7-4001-8cb6-86cc95953aea/sist-en-16416-2023>

## European foreword

This document (EN 16416:2023) has been prepared by Technical Committee CEN/TC 189 “Geosynthetics”, the secretariat of which is held by NBN.

This European Standard shall be given the status of a national standard, either by publication of an identical text or by endorsement, at the latest by August 2023, and conflicting national standards shall be withdrawn at the latest by August 2023.

Attention is drawn to the possibility that some of the elements of this document may be the subject of patent rights. CEN shall not be held responsible for identifying any or all such patent rights.

This document supersedes EN 16416:2013.

In comparison with the previous edition, the following technical modifications have been made:

- Addition of details in Figure 1;
- Addition of details in 7.5 on the compressive stress.

This document has been prepared under a Standardization Request given to CEN by the European Commission and the European Free Trade Association.

Any feedback and questions on this document should be directed to the users' national standards body. A complete listing of these bodies can be found on the CEN website.

According to the CEN-CENELEC Internal Regulations, the national standards organisations of the following countries are bound to implement this European Standard: Austria, Belgium, Bulgaria, Croatia, Cyprus, Czech Republic, Denmark, Estonia, Finland, France, Germany, Greece, Hungary, Iceland, Ireland, Italy, Latvia, Lithuania, Luxembourg, Malta, Netherlands, Norway, Poland, Portugal, Republic of North Macedonia, Romania, Serbia, Slovakia, Slovenia, Spain, Sweden, Switzerland, Türkiye and the United Kingdom.

**EN 16416:2023 (E)****1 Scope**

This document specifies an index test method that covers laboratory measurement of water flux through saturated clay geosynthetic barrier (GBR-C) specimens using a flexible wall permeameter at constant head.

This test method is applicable to GBR-C products with no additional sealing layers attached (e.g. polymeric or bituminous).

This test method specifies a measurement of flux under a prescribed set of conditions that can be used for manufacturing quality control. The test method can also be used to check conformance.

The flux value determined using this test method is not considered to be representative of the in-service flux of a GBR-C.

**2 Normative references**

The following documents are referred to in the text in such a way that some or all of their content constitutes requirements of this document. For dated references, only the edition cited applies. For undated references, the latest edition of the referenced document (including any amendments) applies.

EN ISO 9862, *Geosynthetics — Sampling and preparation of test specimens (ISO 9862)*

ISO 554, *Standard atmospheres for conditioning and/or testing — Specifications*

ISO 11465, *Soil quality — Determination of dry matter and water content on a mass basis — Gravimetric method*

**3 Terms and definitions**

For the purposes of this document, the following terms and definitions apply.

ISO and IEC maintain terminological databases for use in standardization at the following addresses:

- IEC Electropedia: available at <https://www.electropedia.org/>
- ISO Online browsing platform: available at <https://www.iso.org/obp>

**3.1  
flux**

volumetric flow rate per unit area normal to the plane of the product at a specified head

[SOURCE: EN ISO 10318-1:2015, 2.3.3.4]

**4 Apparatus**

The apparatus shall consist of the following.

**4.1 Constant head hydraulic system****4.1.1 General**

The system shall be capable of maintaining constant hydraulic pressures to within  $\pm 2,5$  % and shall include means to measure the hydraulic pressures to within the prescribed tolerance. In addition, the system shall be capable of maintaining a constant head loss across the test specimen to within  $\pm 5$  % and shall include means to measure the head loss with the same uncertainty of measurement or better.

#### 4.1.2 System de-airing

The hydraulic system shall be designed to facilitate rapid and complete removal of free air bubbles from flow lines.

#### 4.1.3 Cell pressure system

The hydraulic system shall have the capability to apply back pressure to the specimen to facilitate saturation. The system shall be capable of maintaining the applied back pressure throughout the duration of the test. The cell pressure system shall be capable of applying, controlling, and measuring the back pressure to within  $\pm 2,5$  % of the applied pressure. The back pressure may be provided by a compressed gas supply, a deadweight acting on a piston, or any other method capable of applying and controlling the back pressure to the tolerance specified in this paragraph.

NOTE Application of gas pressure directly to a liquid will dissolve gas in the liquid. A variety of techniques are available to minimize dissolution of gas in the back-pressure liquid, including separation of gas and liquid phases with a bladder and frequent replacement of the liquid with de-aired water.

### 4.2 Flow Measurement System

#### 4.2.1 Uncertainty of measurement of inflow and outflow

Both inflow and outflow volumes shall be measured unless the lack of leakage, continuity of flow, and cessation of consolidation or swelling can be verified by other means. Required uncertainty of measurement for the flow measured over an interval of time is  $\pm 5$  %.

#### 4.2.2 De-airing and compliance of the system

The flow-measurement system shall contain a minimum of dead space and be capable of complete and rapid de-airing. Rigid tubing shall be used so that volume change of the system in response to changes in pressure is minimized.

#### 4.3 Permeameter cell pressure system

The system for pressurizing the permeameter cell shall be capable of applying and maintaining the cell pressure to within  $\pm 2,5$  % of the applied pressure. However, the effective stress on the test specimen shall be maintained to the desired value with a maximum permissible error of  $\pm 5$  %. The device for pressurizing the cell may consist of a reservoir connected to the permeameter cell and partially filled with de-aired water, with the upper part of the reservoir connected to a compressed gas supply or other source of pressure (see NOTE).

NOTE De-aired water is commonly used for the cell liquid to minimize potential for diffusion of air through the membrane into the specimen. Other liquids, such as oils, which have low gas solubilities, are also acceptable, provided they do not react with components of the permeameter and the flexible membrane. The use of a long (approximately 5 m to 7 m) tube connecting the pressurized cell liquid to the cell can help delay the appearance of air in the cell liquid and to reduce the flux of dissolved air into the cell.

#### 4.4 Permeameter Cell

An apparatus shall be provided in which the specimen and porous end pieces, enclosed by a flexible membrane sealed to the cap and base, are subjected to controlled liquid pressures. A schematic diagram of a typical cell is shown in Figure 1.

**EN 16416:2023 (E)**

The permeameter cell shall allow for observation of changes in height of the specimen, either by observation through the cell wall using a suitable instrument or by monitoring of either a loading piston or an extensometer extending through the top plate of the cell bearing on the top cap and attached to a suitable measuring device.

The piston or extensometer – if used – shall pass through a bushing and seal incorporated into the top plate and shall be loaded with sufficient force to compensate for the cell pressure acting over the cross-sectional area of the piston where it passes through the seal. If deformations are measured, the deformation indicator shall be graduated to 0,01 mm or better and shall have an adequate travel range. This piston or extensometer shall not restrict the swelling of the specimen.

To facilitate gas removal, and thus saturation of the hydraulic system, four drainage lines leading to the specimen, two each to the base and top cap, are recommended. The drainage lines shall be controlled by no-volume-change valves, such as ball valves, and shall be designed to minimize dead space in the lines.

**4.5 Top cap and base**

An impermeable, rigid top cap and base shall be used to support the specimen and provide for transmission of permeant liquid to and from the specimen. The base shall prevent leakage, lateral motion, or tilting, and the top cap shall be designed to receive the piston or extensometer, if used, such that the piston-to-top cap contact area is concentric with the cap.

The surface of the base and top cap that contacts the membrane to form a seal shall be smooth and free of scratches.

iTeh STANDARD PREVIEW  
(standards.iteh.ai)

SIST EN 16416:2023

<https://standards.iteh.ai/catalog/standards/sist/582a57de-26c7-4001-8cb6-86cc95953aea/sist-en-16416-2023>

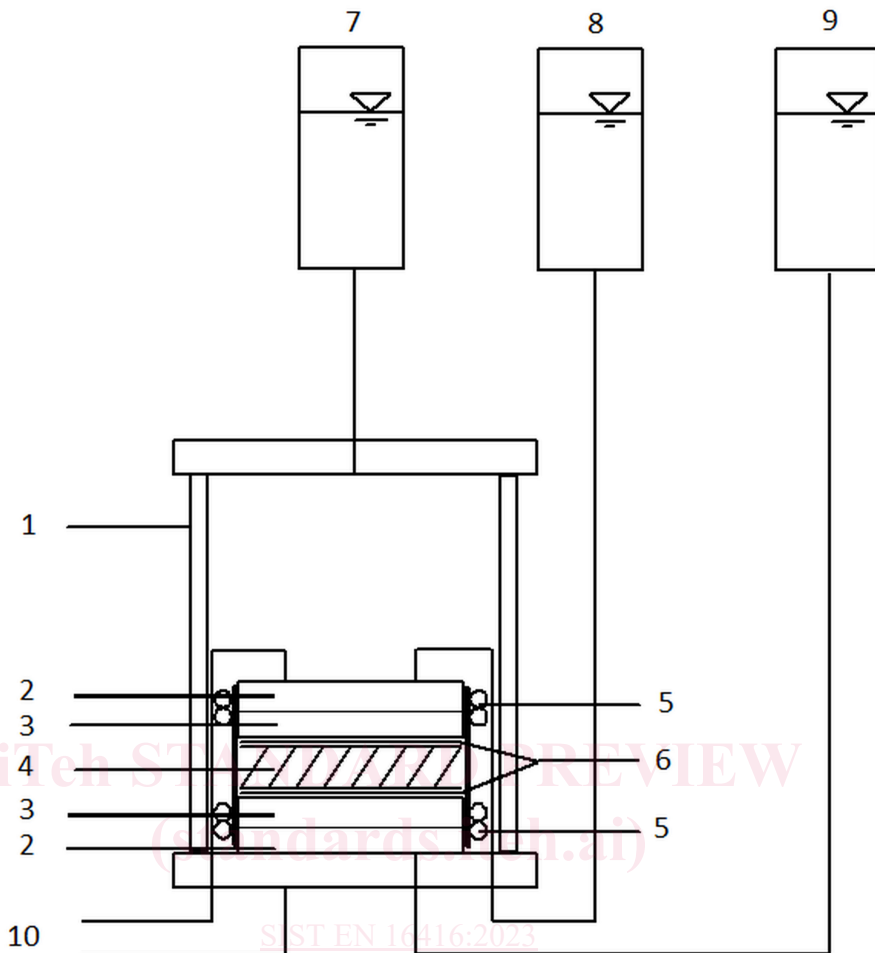

**Key**

1 permeameter cell	6 filter paper
2 end piece	7 back pressure system
3 porous piece	8 outflow volume measuring device
4 specimen	9 inflow volume measuring device
5 rubber O-rings	10 vent lines

**Figure 1 — Permeameter cell and test set-up****4.6 Flexible membranes**

The flexible membrane used to encase the specimen shall provide reliable protection against leakage. The membrane shall be carefully inspected prior to use and if any flaws or pinholes are evident, the membrane shall be discarded. To minimize restraint of the specimen, the diameter or width of the unstretched membrane shall be between 90 % and 95 % of that of the specimen. The membrane shall be sealed to each of the specimen base and cap with two rubber O-rings for which the unstressed, inside diameter or width is less than 90 % of the diameter or width of the base and cap, or by any other method that will produce an adequate seal.

**EN 16416:2023 (E)**

NOTE If necessary, membranes can be tested for flaws by placing them around a form sealed at both ends with rubber O-rings, subjecting them to a small air pressure on the inside, and then dipping them into water. If air bubbles come up from any point on the membrane, or if any visible flaws are observed, the membrane is not suitable for use in the test.

**4.7 Porous end pieces**

The porous end pieces shall be of material that is not attacked by the specimen or permeant liquid. The end pieces shall have plane and smooth surfaces and be free of cracks, chips, and non-uniformities. They shall be checked regularly to ensure that they are not clogged.

The porous end pieces shall have a diameter no greater than  $(100 \pm 2)$  mm, and their thickness shall be sufficient to prevent breaking.

The hydraulic conductivity of the porous end pieces shall be substantially greater than that of the specimen to be tested such that there is no significant impedance of flow. Including the porous end pieces in the procedures described in 7.1 will ensure that no significant impedance occurs.

**4.8 Filter paper**

To prevent intrusion of material into the pores of the porous end pieces, one or more sheets of filter paper shall be placed between the top and bottom porous end pieces and the specimen. The hydraulic conductivity of the filter paper shall be substantially greater than that of the specimen to be tested such that there is no significant impedance of flow. Including the filter paper in the procedures set forth in 7.1 will ensure that no significant impedance occurs.

NOTE An appropriate type of filter paper is Whatman® No. 1 (or equivalent).<sup>1</sup>

**4.9 Devices for measuring the dimensions of the specimen**

Devices used to measure dimensions of the specimen other than the thickness shall be capable of measuring with an uncertainty of measurement of  $\pm 0,3$  mm or better and shall be constructed such that their use will not disturb the specimen.

**4.10 Equipment for mounting the specimen**

Equipment for mounting the specimen in the permeameter cell shall include a membrane stretcher or cylinder and ring for expanding and placing O-rings on the base and top cap to seal the membrane.

**4.11 Vacuum pump**

This pump assists with the de-airing of the permeameter system and the saturation of the specimens.

**4.12 Temperature maintaining device**

Testing shall be carried out at ambient temperature that shall not vary more than  $\pm 3$  °C. This temperature shall be periodically measured and recorded, at a minimum, at the beginning of the permeation phase and at the end of the permeation phase of the test.

---

<sup>1</sup> Whatman® No.1 is an example of a suitable product available commercially. This information is given for the convenience of users of this document and does not constitute an endorsement by CEN of this product.