Refractories — Test methods for thermal shock resistance

*Matériaux réfractaires — Méthodes d'essai de la résistance aux chocs
thermiques*

iTeh STANDARD PREVIEW
(standards.iteh.ai)

[ISO 21736:2020](https://standards.iteh.ai/catalog/standards/sist/d1b7c772-5b69-4ec4-998e-375316fef663/iso-21736-2020)

<https://standards.iteh.ai/catalog/standards/sist/d1b7c772-5b69-4ec4-998e-375316fef663/iso-21736-2020>



iTeh STANDARD PREVIEW
(standards.iteh.ai)

ISO 21736:2020

<https://standards.iteh.ai/catalog/standards/sist/d1b7c772-5b69-4ec4-998e-375316fef663/iso-21736-2020>



COPYRIGHT PROTECTED DOCUMENT

© ISO 2020

All rights reserved. Unless otherwise specified, or required in the context of its implementation, no part of this publication may be reproduced or utilized otherwise in any form or by any means, electronic or mechanical, including photocopying, or posting on the internet or an intranet, without prior written permission. Permission can be requested from either ISO at the address below or ISO's member body in the country of the requester.

ISO copyright office
CP 401 • Ch. de Blandonnet 8
CH-1214 Vernier, Geneva
Phone: +41 22 749 01 11
Email: copyright@iso.org
Website: www.iso.org

Published in Switzerland

Contents

	Page
Foreword	iv
1 Scope	1
2 Normative references	1
3 Terms and definitions	1
4 Method 1: water quenching	2
4.1 General.....	2
4.2 Principle.....	2
4.3 Equipment.....	2
4.3.1 Experimental furnace.....	2
4.3.2 Cooling water channel.....	2
4.3.3 Test piece clamp.....	2
4.3.4 Drying oven.....	2
4.3.5 Grid, mesh size of 5 mm × 5 mm.....	2
4.4 Test pieces.....	2
4.4.1 Sampling.....	2
4.4.2 Shape, dimensions and preparation of test pieces.....	2
4.5 Test procedure.....	4
4.5.1 Heating.....	4
4.5.2 Cooling.....	5
4.6 Results expression.....	5
5 Method 2: compressed air quenching	5
5.1 General.....	5
5.2 Principle.....	6
5.3 Equipment.....	6
5.4 Test pieces.....	6
5.4.1 Sampling.....	6
5.4.2 Shape, dimensions and preparation of test pieces.....	6
5.5 Test procedure.....	7
5.5.1 Heating.....	7
5.5.2 Cooling.....	7
5.5.3 Determination.....	7
5.6 Results expression.....	7
6 Method 3: air quenching	8
6.1 General.....	8
6.2 Principle.....	8
6.3 Equipment.....	8
6.4 Test pieces.....	9
6.4.1 Sampling.....	9
6.4.2 Shape, dimensions and preparation of test pieces.....	9
6.5 Test procedures.....	9
6.5.1 Heating.....	9
6.5.2 Cooling.....	9
6.5.3 Results expression.....	9
7 Test report	10
Annex A (informative) Precision data of thermal shock resistance tests	11

Foreword

ISO (the International Organization for Standardization) is a worldwide federation of national standards bodies (ISO member bodies). The work of preparing International Standards is normally carried out through ISO technical committees. Each member body interested in a subject for which a technical committee has been established has the right to be represented on that committee. International organizations, governmental and non-governmental, in liaison with ISO, also take part in the work. ISO collaborates closely with the International Electrotechnical Commission (IEC) on all matters of electrotechnical standardization.

The procedures used to develop this document and those intended for its further maintenance are described in the ISO/IEC Directives, Part 1. In particular, the different approval criteria needed for the different types of ISO documents should be noted. This document was drafted in accordance with the editorial rules of the ISO/IEC Directives, Part 2 (see www.iso.org/directives).

Attention is drawn to the possibility that some of the elements of this document may be the subject of patent rights. ISO shall not be held responsible for identifying any or all such patent rights. Details of any patent rights identified during the development of the document will be in the Introduction and/or on the ISO list of patent declarations received (see www.iso.org/patents).

Any trade name used in this document is information given for the convenience of users and does not constitute an endorsement.

For an explanation of the voluntary nature of standards, the meaning of ISO specific terms and expressions related to conformity assessment, as well as information about ISO's adherence to the World Trade Organization (WTO) principles in the Technical Barriers to Trade (TBT) see www.iso.org/iso/foreword.html.

This document was prepared by Technical Committee ISO/TC 33, *Refractories*.

Any feedback or questions on this document should be directed to the user's national standards body. A complete listing of these bodies can be found at www.iso.org/members.html.

Refractories — Test methods for thermal shock resistance

1 Scope

This document specifies the principle, equipment, test pieces, procedures, result expression and test report of test methods for thermal shock resistance of refractories.

Three test methods are included in this document. Each one is applicable to a different product type and their test results are not comparable.

The test method, the test temperature and the test condition are intended to be negotiated by corresponding parties.

This document does not purport to address all of the safety concerns, if any, associated with its use. It is the responsibility of the user to establish appropriate safety and health practices and determine the applicability of regulatory limitations prior to use.

2 Normative references

The following documents are referred to in the text in such a way that some or all of their content constitutes requirements of this document. For dated references, only the edition cited applies. For undated references, the latest edition of the referenced document (including any amendments) applies.

ISO 836, *Terminology for refractories*

ISO 1927-2, *Monolithic (unshaped) refractory products — Part 2: Sampling for testing*

ISO 1927-5, *Monolithic (unshaped) refractory products — Part 5: Preparation and treatment of test pieces*

ISO 5014, *Dense and insulating shaped refractory products — Determination of modulus of rupture at ambient temperature*

ISO 5022, *Shaped refractory products — Sampling and acceptance testing*

3 Terms and definitions

For the purposes of this document, the terms and definitions given in ISO 836 and the following apply.

ISO and IEC maintain terminological databases for use in standardization at the following addresses:

- ISO Online browsing platform: available at <https://www.iso.org/obp>
- IEC Electropedia: available at <http://www.electropedia.org/>

3.1

water quenching

rapid quenching of the fast-heated test pieces in flowing water of 5 °C to 35 °C

3.2

compressed air quenching

rapid quenching of the fast-heated test pieces in 0,1 MPa compressed air of ambient temperature

3.3

air quenching

quenching of the fast-heated test pieces in natural air of ambient temperature

4 Method 1: water quenching

4.1 General

Method 1 (water quenching) is applicable to dense aluminium silicate refractory products, but not to basic refractory products, silica refractory products, fused cast refractory products, refractory products with apparent porosity higher than 45 % or the refractories whose thermal shock resistance is hard to evaluate for low thermal shock cycles or reactions with water.

4.2 Principle

In the conditions of the specified testing temperature and water medium, the test piece with the specified shape and dimensions suffers thermal shocks. The damage degree of the hot end surface of the test piece is adopted to describe the thermal shock resistance of the refractories.

4.3 Equipment

4.3.1 Experimental furnace

Use an electric furnace whose temperature can be controlled in accordance with the specifications in 4.5. The temperature distribution of the test pieces loading area shall be uniform to ensure the temperature difference between two random points on the hot end surface is not higher than 10 °C. The uniform temperature zone shall be able to hold at least three test pieces simultaneously. One end of the thermocouple for temperature determination shall be sealed and 20 mm ± 5 mm away from the hot end surface of the test pieces. Meanwhile, the temperature record and display devices shall be equipped to control, record and display the furnace temperature continuously. A diagram of the heating device is shown in [Figures 1](#) and [2](#).

4.3.2 Cooling water channel

The channel shall be able to hold multiple test pieces for rapid quenching simultaneously and ensure the inflow and outflow water temperature rise is not higher than 10 °C. A diagram of the cooling device is shown in [Figures 3](#) and [4](#).

4.3.3 Test piece clamp

The clamp is used to fix test pieces for heating or cooling.

4.3.4 Drying oven

The drying oven shall be able to control the test temperature at 110 °C ± 5 °C.

4.3.5 Grid, mesh size of 5 mm × 5 mm

The grid is used to determine the hot end area of test pieces [114 mm × 64 (74) mm] in grid number.

4.4 Test pieces

4.4.1 Sampling

Sampling of shaped refractory products and monolithic refractories shall be conducted in accordance with ISO 5022 and ISO 1927-2, respectively, or negotiated by corresponding parties.

4.4.2 Shape, dimensions and preparation of test pieces

Standard bricks with dimensions of 230 mm × 114 mm × 64 (74) mm shall be adopted for testing.

For oversized bricks, test pieces with these dimensions shall be cut from the original bricks. One test piece for one brick only. If the test pieces of the specified dimensions cannot be obtained, the other dimensions can be negotiated by corresponding parties.

Test piece preparation of monolithic refractories shall be conducted in accordance with ISO 1927-5.

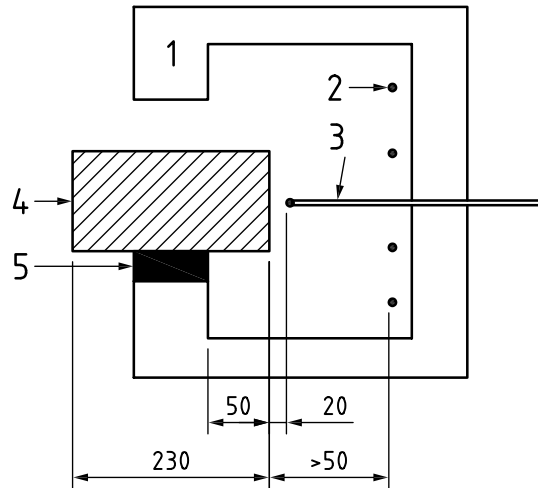

Key

- 1 furnace body
- 2 heating element
- 3 thermocouple
- 4 test pieces
- 5 heat insulation material

iTeh STANDARD PREVIEW
(standards.iteh.ai)

ISO 21736:2020

<https://standards.iteh.ai/catalog/standards/sist/d11b7c772-5b69-4e4-998e-375316fef663/iso-21736-2020>

Figure 1 — Side view of heating device

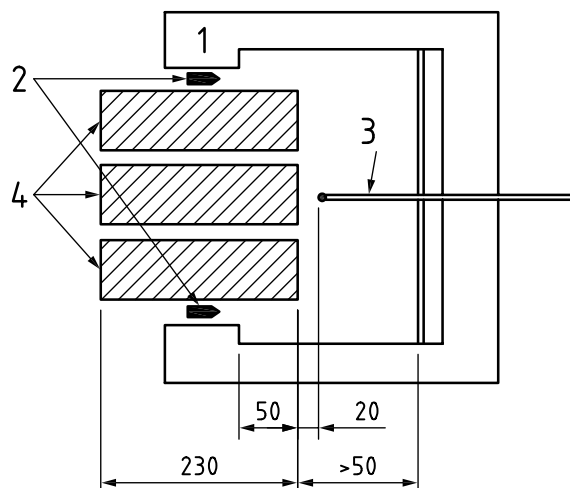

Key

- 1 furnace body
- 2 heat insulation material
- 3 thermocouple
- 4 test pieces

Figure 2 — Planform for heating device

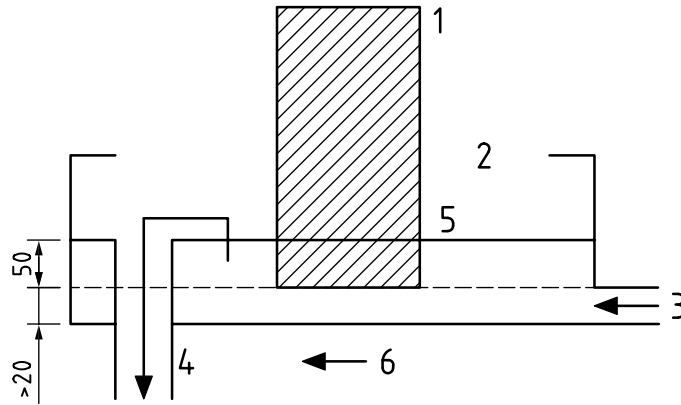

Key

- 1 test piece
- 2 water channel
- 3 water intake
- 4 water outlet
- 5 water surface
- 6 direction of water flow

Figure 3 — Side view of cooling device

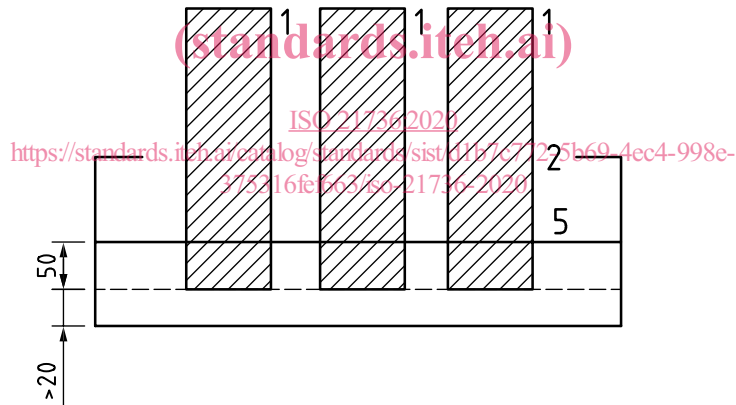

Figure 4 — Elevation view of cooling device

4.5 Test procedure

4.5.1 Heating

Dry the test pieces in an electric desiccator at $110\text{ °C} \pm 5\text{ °C}$ to a constant mass. Clamp the test pieces with the test piece clamp at intervals no smaller than 10 mm; overlapping is not permitted. Ensure that a section with a length of 50 mm from each test piece can suffer the thermal shock. Fill the space between the clamped parts of test pieces with the insulating materials thicker than 10 mm. Measure the area of the hot end surface [114 mm × 64 (74) mm] of the test pieces in grid number A1 with a grid and record.

Preheat the furnace to the test temperature $\pm 10\text{ °C}$ and hold for 15 min. Transfer the test pieces into the hearth rapidly. The hot end surface of the test pieces shall be $\geq 50\text{ mm}$ away from the heating element surface. Fill the space between the test pieces and the furnace door with the insulating materials in time.

The test temperatures shall be negotiated by the corresponding parties and marked in the test report; the recommended test temperature is 1 100 °C.

After the test pieces are put into the furnace, the furnace temperature drop shall be ≤ 50 °C, and it shall return to the test temperature within 5 min. The test pieces shall be held at the test temperature for 20 min after regaining temperature.

4.5.2 Cooling

After rapid heating, take out the test pieces and immerse the hot end of the test pieces $50 \text{ mm} \pm 5 \text{ mm}$ deep in the flowing water of 5 °C to 35 °C. The immersed test piece end shall be $\geq 20 \text{ mm}$ from the water channel bottom. The temperature rise between inflow water and outflow water shall be ≤ 10 °C by adjusting the water flow rate. During quenching, close the furnace door in time to keep the furnace temperature at the test temperature ± 10 °C.

After water quenching for 3 min in the channel, take out the test pieces rapidly and leave the test pieces in air for ≥ 5 min. Measure the undamaged area of the hot end surface [$114 \text{ mm} \times 64$ (74) mm] of the test pieces in grid number A2 and record.

When the test pieces are left in air for ≥ 5 min and the furnace temperature returns to the test temperature, transfer the hot end of the test pieces into the furnace rapidly. Repeat these procedures until (50 ± 5) % of the hot end surface is damaged. Record the thermal shock cycle number or end the test at the negotiated cycles.

During the test, the mechanical damage between the test pieces and the furnace door or the water channel is not permitted.

4.6 Results expression

The thermal shock cycle in which half (or more) of the hot end surface of the test piece is damaged during water quenching is regarded as the result of the thermal shock resistance test.

The hot end surface damage rate of test pieces is calculated using the grid number of the hot end surface A_1 before the test and the grid number of the undamaged hot end surface A_2 after the test according to [Formula \(1\)](#).

$$P = \frac{A_1 - A_2}{A_1} \times 100\% \quad (1)$$

where

P is the hot end surface damage rate of the test piece, in %;

A_1 is the grid number of the hot end surface before the test;

A_2 is the grid number of the undamaged hot end surface after the test.

The damage rate shall be rounded to the nearest 1 %.

During water quenching, if half of the hot end surface is damaged this thermal shock cycle is valid.

If the test piece is damaged by external forces the test is invalid. In this case, retest.

5 Method 2: compressed air quenching

5.1 General

Method 2 (compressed air quenching) is applicable to basic refractory products, silica refractory products, fused cast refractory products and the refractories whose thermal shock resistance is hard