



Designation: D5128 – 09

## Standard Test Method for On-Line pH Measurement of Water of Low Conductivity<sup>1</sup>

This standard is issued under the fixed designation D5128; the number immediately following the designation indicates the year of original adoption or, in the case of revision, the year of last revision. A number in parentheses indicates the year of last reappraisal. A superscript epsilon ( $\epsilon$ ) indicates an editorial change since the last revision or reappraisal.

### 1. Scope

1.1 This test method covers the precise on-line determination of pH in water samples of conductivity lower than 100  $\mu\text{S}/\text{cm}$  (see [Table 1](#) and [Table 2](#)) over the pH range of 3 to 11 (see [Fig. 1](#)), under field operating conditions, utilizing a sealed, non-refillable, reference electrode. pH measurements of water of low conductivity are problematical for conventional pH electrodes, methods, and related measurement apparatus.

1.2 This test method includes the procedures and equipment required for the continuous pH measurement of low conductivity water sample streams including the requirements for the control of sample stream pressure, flow rate, and temperature. For off-line pH measurements in low conductivity samples, refer to Test Method [D5464](#).

1.3 *This standard does not purport to address all of the safety concerns, if any, associated with its use. It is the responsibility of the user of this standard to establish appropriate safety and health practices and determine the applicability of regulatory limitations prior to use.*

### 2. Referenced Documents

2.1 *ASTM Standards:*<sup>2</sup>

- [D1129 Terminology Relating to Water](#)
- [D1193 Specification for Reagent Water](#)
- [D1293 Test Methods for pH of Water](#)
- [D2777 Practice for Determination of Precision and Bias of Applicable Test Methods of Committee D19 on Water](#)
- [D3864 Guide for On-Line Monitoring Systems for Water Analysis](#)
- [D4453 Practice for Handling of High Purity Water Samples](#)
- [D5464 Test Method for pH Measurement of Water of Low Conductivity](#)

<sup>1</sup> This test method is under the jurisdiction of ASTM Committee [D19](#) on Water and is the direct responsibility of Subcommittee [D19.03](#) on Sampling Water and Water-Formed Deposits, Analysis of Water for Power Generation and Process Use, On-Line Water Analysis, and Surveillance of Water.

Current edition approved Oct. 1, 2009. Published October 2009. Originally approved in 1990. Last previous edition approved in 2005 as [D5128 90](#) (2005). DOI: 10.1520/D5128-09.

<sup>2</sup> For referenced ASTM standards, visit the ASTM website, [www.astm.org](http://www.astm.org), or contact ASTM Customer Service at [service@astm.org](mailto:service@astm.org). For *Annual Book of ASTM Standards* volume information, refer to the standard's Document Summary page on the ASTM website.

### 3. Terminology

3.1 *Definitions of Terms Specific to This Standard:*

3.1.1 *liquid junction potential*—a dc potential that appears at the point of contact between the reference electrode's salt bridge and the sample solution. Ideally this potential is near zero, and is stable. However, in low conductivity water it becomes larger by an unknown amount, and is a zero offset. As long as it remains stable its effect can be minimized by “grab sample” calibration **(1)**.<sup>3</sup>

3.1.2 *streaming potential*—the static electrical charge that is induced by the movement of a low ionic strength solution having a high electrical resistivity or low electrical conductivity (such as pure water), across relatively non-conductive surfaces such as the pH measurement electrode's glass membrane or other non-conductive wetted materials found in flowing sample streams.

3.2 *Definitions:* For definitions of other terms used in this test method, refer to Terminology [D1129](#) and Practice [D3864](#).

### 4. Summary of Test Method

4.1 pH is measured by a pair of electrodes contained in an all stainless steel flow cell. The pH measurement half cell is constructed of a glass membrane suitable for continuous service in low conductivity water. Many modern pH electrodes are available that perform well in this service. However, the bulb impedance should be kept low to minimize the effects of “streaming potential” (see [3.1.2](#)). The reference half cell is sealed (requiring no electrolyte replenishment) and is constructed in such a manner that the salt bridge, while making diffusion contact to the sample, resists significant dilution for periods up to several months on continuous operation.

4.2 This test method describes the apparatus and procedures to be used for the continuous on-line pH measurement of low conductivity water sample streams. The type of pH sensor assembly and pH instrument interface module are described in detail. The requirements for sample stream manifolds for the conditioning of sample pressure and flow rate are defined, and arrangements for this associated equipment are illustrated. Guidelines for the proper installation and calibration of the pH

<sup>3</sup> The boldface numbers given in parentheses refer to a list of references at the end of this standard.

**TABLE 1 Calculated Conductivity and pH Values at 25°C of Low Concentrations of NaOH in Pure Water<sup>A</sup>**

NOTE 1—This table tabulates the theoretical conductivity and pH values of low levels of NaOH in pure water as calculated from available thermodynamic data.

NOTE 2—To illustrate the high sensitivity of the sample pH at these low concentrations to contaminants, the last column lists errors that would result if the sample were contaminated with an additional 1 mg/L through sample or equipment handling errors.

Sample Concentration, mg/L	Sample Conductivity, $\mu\text{S/cm}$	Sample pH	$\Delta$ pH Error from Additional 1 mg/L NaOH Contaminate
0.001	0.055	7.05	$\Delta$ 2.35
0.010	0.082	7.45	$\Delta$ 1.95
0.100	0.625	8.40	$\Delta$ 1.03
1.0	6.229	9.40	$\Delta$ 0.30
8.0	49.830	10.30	$\Delta$ 0.05

<sup>A</sup> Data courtesy of Ref (13). This data developed from algorithms originally published in Ref (14).

**TABLE 2 Calculated Conductivity and pH Values at 25°C of Low Concentrations of HCl in Pure Water<sup>A</sup>**

NOTE 1—This table tabulates the theoretical conductivity and pH values of low levels of HCl in pure water as calculated from available thermodynamic data

NOTE 2—To illustrate the high sensitivity of the sample pH at these low concentrations to contaminants, the last column lists errors that would result if the sample were contaminated with an additional 1 mg/L through sample or equipment handling errors.

Sample Concentration, mg/L	Sample Conductivity, $\mu\text{S/cm}$	Sample pH	$\Delta$ pH Error from Additional 1 mg/L HCl Contaminate
0.001	0.060	6.94	$\Delta$ 2.38
0.010	0.134	6.51	$\Delta$ 1.95
0.100	1.166	5.56	$\Delta$ 1.03
1.0	11.645	4.56	$\Delta$ 0.30
8.0	93.163	3.66	$\Delta$ 0.05

<sup>A</sup> Data courtesy of Ref (13). This data developed from algorithms originally published in Ref (14).

sensor and associated sample manifold are discussed along with the precautions that must be considered concerning sample contamination and representative sampling for calibration purposes.

4.3 The apparatus and procedures described in this test method are intended to be used with most state-of-the-art, process-grade, pH analyzer/transmitter instruments currently in use or available from the major manufacturers of such instrumentation.

### 5. Significance and Use

5.1 pH measurements are typically made in solutions that contain relatively large amounts of acid, base, or dissolved salts. Under these conditions, pH determinations may be made quickly and precisely. Continuous on-line pH measurements in water samples of low conductivity are more difficult (2, 3). These low ionic strength solutions are susceptible to contamination from the atmosphere, sample stream hardware, and the pH electrodes. Variations in the constituent concentration of low conductivity waters cause liquid junction potential shifts

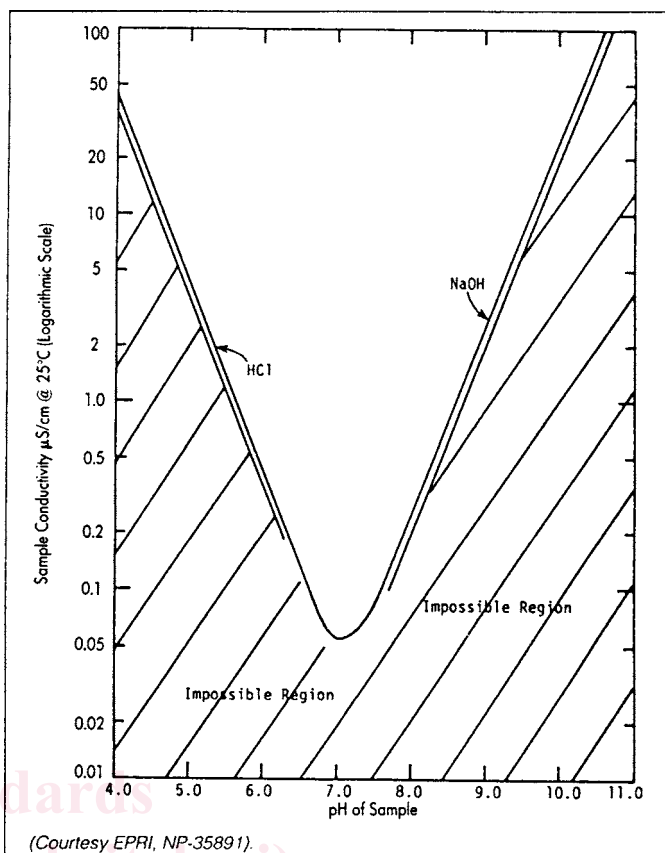

**FIG. 1 Restrictions Imposed by the Conductivity pH Relationship**

(see 3.1.1) resulting in pH measurement errors. The aggressive nature and the high electrical resistance of pure and ultra-pure, low conductivity waters may degrade the pH measurement electrodes resulting in unstable and drifting pH output signals.

5.2 It is essential to make on-line pH measurements of low conductivity water as accurately as possible to determine the proper control of pH adjustment chemicals, the effectiveness of demineralizer equipment, the event and nature of impurity contamination of the water, and information pertaining to the overall status of the pure water system.

### 6. Interferences

6.1 Sample systems for high purity, low conductivity waters are especially sensitive to contamination from atmospheric gases (especially carbon dioxide, see Appendix X1 and Table 3) from collection of “crud” (insoluble deposits of iron oxide and other by-products of metallic corrosion that are present throughout the system) in sample lines, from exposure to high ionic strength calibration buffers, from incorrect sample system installation techniques, and from excessive KCl leakage from the pH reference half-cell. Refer to Practice D4453 and Refs (4) and (5).

6.2 Streaming potentials that are developed in flowing, low conductivity water sample streams, and which are dynamic in nature, will add to the potential (millivolt) generated by the pH glass measurement half cell in proportion to the  $\text{H}^+$  and  $\text{OH}^-$  activities. This resultant pH error appears as a noisy and

**TABLE 3 Calculated pH and Conductivity Values at 25°C of Water Solutions Containing Only Ammonia and Carbon Dioxide<sup>A</sup>**

Ammonia mg/L	Carbon Dioxide 0 mg/L		Carbon Dioxide 0.2 mg/L		pH Shift Caused by 0.2 mg/L CO <sub>2</sub> Contamination of Sample
	μS/cm	pH	μS/cm	pH	
0	0.056	7.00	0.508	5.89	Δ 1.11 pH
0.12	1.462	8.73	1.006	8.18	Δ 0.55 pH
0.51	4.308	9.20	4.014	9.09	Δ 0.11 pH
0.85	6.036	9.34	5.788	9.26	Δ 0.08 pH
1.19	7.467	9.44	7.246	9.38	Δ 0.06 pH

<sup>A</sup> Data extracted from Ref (6).

drifting pH signal from the pH sensor. These effects are minimized by using a conductive flow cell and, in some cases, a symmetrical combination measurement/reference electrode (7).

6.3 Liquid junction potentials, that are most evident in low conductivity waters, shift the potential of the pH reference half cell resulting in both short and long-term pH measurement errors. The instability of liquid junction potentials depends upon reference half-cell design, electrical conductivity of the sample water, time, and sampling conditions such as flow rate and pressure. Exposure of the pH sensor electrodes to pH calibration buffer solutions, that have a higher ionic strength than the pure water sample stream, causes significant instability in liquid junction potentials resulting in pH measurement errors. This pH measurement error is caused by the shifting of the pH electrodes from one ionic strength solution to another.

6.3.1 Liquid junction potentials must be stable so as to make reliable calibration of the system possible. Reference electrodes that have been exposed to the much higher ionic strength of buffer solutions will require considerable rinse time to establish a stable liquid junction potential in high purity water. To determine the pH electrode's suitability in low conductivity water, a comparative low conductivity water sample calibration, or on-line calibration with low conductivity standards similar to the samples being addressed should be performed, as described in 9.5.

6.3.2 The severity of the error resulting from a liquid junction potential shift when the ionic strength of the sample changes, for example, measuring 1.0 mg/L ammonia (pH = 9.38 and conductivity = 6.58 μS/cm) followed by measuring 0.1 mg/L ammonia (pH = 8.65 and conductivity = 1.24 μS/cm) is not known and is a deficiency in the state-of-the-art. See Table 4.

6.4 Temperature stability of the flowing sample stream and pH correlation to the desired 25°C reference temperature has a direct effect which is more significant in low conductivity water on the accuracy of the pH measurement (3, 7, 10, 11, 12, 13). A discussion of the temperature effects on pH measurements is presented in Appendix X2.

6.5 The flow rate to the pH electrodes and related apparatus must be controlled in order to obtain repeatable results. A discussion of the flow sensitivity is presented in Appendix X3.

**TABLE 4 pH versus Specific Conductivity At 25°C<sup>A</sup>**

NOTE 1—This table tabulates the theoretical pH and specific conductivity values of low levels of ammonium hydroxide in reagent water as calculated from available thermodynamic data.

Ammonia, mg/L NH <sub>3</sub>	Ammonium Hy- droxide, mg/L NH <sub>4</sub> OH	pH	Specific Conductivity, μS/cm
0.10	0.21	8.65	1.24
0.15	0.31	8.79	1.72
0.20	0.41	8.89	2.15
0.25	0.51	8.96	2.54
0.30	0.62	9.02	2.91
0.35	0.72	9.07	3.25
0.40	0.82	9.11	3.57
0.45	0.93	9.15	3.88
0.50	1.03	9.18	4.17
1.00	2.06	9.38	6.58
1.50	3.09	9.49	8.47
2.00	4.11	9.56	10.08

<sup>A</sup> Data courtesy of Ref (8). This data developed from algorithms originally published in Ref (9).

## 7. Apparatus

7.1 A complete high purity water pH sensor assembly is required. The pH flow cell, connecting tubing, and electrode housings should be constructed of stainless steel (316 is preferred and electropolished 304 is acceptable), and the whole system should be properly grounded. Provisions for the necessary shielding to eliminate noise pick-up and for minimizing air entrapment and "crud" accumulation shall be furnished in the flow cell and sensor assembly design. The use of plastics such as TFE and PVDF and other wetted materials that will not leach any contaminants into the sample may be incorporated into the sensor assembly where required.

NOTE 1—The temperature response of the measurement electrodes may affect the accuracy and repeatability of the measurement. Electrodes that quickly equilibrate to each other and the sample temperature must be selected for this service. Refer to Practice D1293, X 1D1293.2 and Ref (4).

NOTE 2—Continuous exposure of the pH electrode to low ionic strength solutions may result in the degradation of the glass membrane portion of some pH electrodes (14). Electrodes suitable for continuous service in low conductivity water should be included in the pH sensor assembly.

NOTE 3—Changes in liquid junction potentials (1) with time and eventual degradation of the reference half cell caused by diffusion of low ionic strength sample water into the high ionic strength electrolyte of the half cell, must be avoided in order to effect an accurate and stable pH measurement. A sealed reference half cell (requiring no electrolyte replenishment) that is constructed in such a manner that the salt bridge, while making diffusion contact to the sample, resists significant dilution for periods up to several months on continuous operation in low conductivity water measurements, must be included in the pH sensor assembly. A trace amount of KCl will diffuse with time into the sample.

7.2 A sample stream manifold constructed of all stainless steel, PTFE, and glass wetted components as shown in Fig. 2 shall be used immediately upstream of the pH sensor. The manifold will provide proper sample stream pressure and flow rate control secondary to primary sample cooling and pressure regulation. This manifold shall also provide grab sample outlet for proper calibration of the pH sensor. This manifold shall be constructed in such a manner that when a grab sample is being taken for calibration purposes, neither the sample flow rate nor pressure shall be permitted to vary at the on-line pH sensor location.

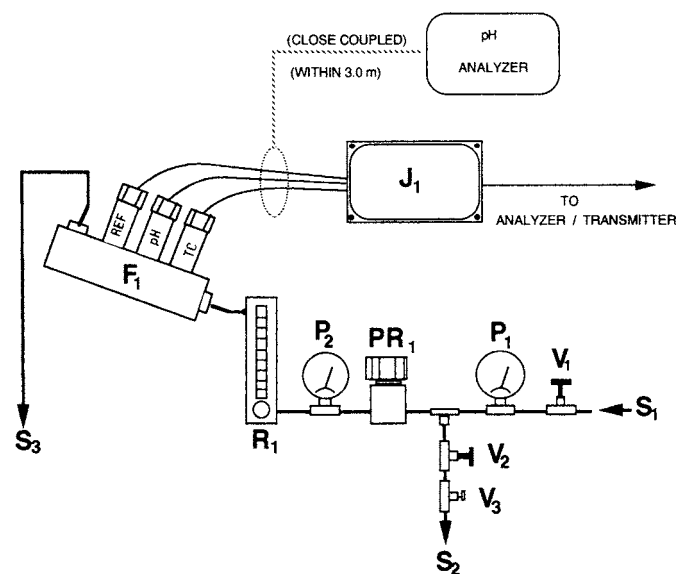

<b>S<sub>1</sub></b> SAMPLE INLET, 6.35 mm (1/4 in.) STAINLESS STEEL TUBE FITTING	<b>PR<sub>1</sub></b> SECONDARY PRESSURE REGULATOR, 0 - 172.4 kPa (gage) (0 - 25 psig)
<b>V<sub>1</sub></b> HIGH PRESSURE SAMPLE INLET SHUT - OFF VALVE	<b>R<sub>1</sub></b> ROTAMETER, WITH CONTROL VALVE, 0 - 600 mL/min
<b>P<sub>1</sub></b> SAMPLE INLET PRESSURE GAUGE 0 - 689.4 kPa (gage) (0 - 100 psig)	<b>P<sub>2</sub></b> FLOW-CELL PRESSURE GAUGE, 0 - 172.4 kPa (gage) (0 - 25 psig)
<b>V<sub>2</sub></b> GRAB SAMPLE VALVE / ON-OFF	<b>F<sub>1</sub></b> HIGH PURITY WATER pH SENSOR
<b>V<sub>3</sub></b> TAMPER RESISTANT FLOW RATE VALVE, MAX. 200 mL/min AT SPECIFIED SYSTEM PRESSURE	<b>S<sub>3</sub></b> SAMPLE OUTLET, TO DRAIN, 6.35 mm (1/4 in.), STAINLESS STEEL TUBE FITTING
<b>S<sub>2</sub></b> GRAB SAMPLE OUTLET	<b>J<sub>1</sub></b> JUNCTION BOX WITH INTERFACE MODULE

FIG. 2 Schematic Sample System

7.3 When the high purity water pH sensor assembly is not directly coupled to the pH analyzer (within 3 m (10 ft.)), an interface module<sup>3</sup> located in a National Electrical Manufacturers Association (NEMA) 4X junction box within 3 m (10 ft) of the on-line pH sensor shall be provided. This interface module shall condition the pH signal by providing differential amplification of the pH electrode half-cells, electrical noise filtration, temperature compensation, and proper conditioning of the pure water pH signal for interface with most process quality pH analyzer/transmitters. Refer to Fig. 2.

## 8. Reagents

8.1 *Commercial Buffer Solutions*—Commercially available prepared buffers traceable to National Institute of Standards and Technology (NIST) standards should be adequate for the calibration procedures in 9.2 – 9.5. These commercial buffer solutions usually have pH values near 4, 7, and 10 pH at 25°C. The exact pH of the buffer will change with temperature and this pH versus temperature data will be provided by the purveyor of the specific buffer. Refer to Method A in Test Method D1293 for the preparation of reference buffer solutions if desired.

8.2 *Buffer A*—Commercially available 7.00 pH buffer.

8.3 *Buffer B*—Commercially available 4.00 pH buffer.

8.4 *Buffer C*—Commercially available 10.00 pH buffer.

8.5 *Purity of Water*—Reference to water shall mean water that meets or exceeds the quantitative specifications for Type II reagent water of Specification D1193, Section 1.1.

## 9. Calibration

9.1 Perform initial and subsequent start-ups of the on-line pH sensor in accordance with manufacturer's instructions.

9.2 Perform a two point calibration of the pH measurement and reference electrodes after removing them from the on-line pH sensor flow chamber. This will be the only time when it is necessary to perform a sensor calibration using pH buffer solutions to determine that the pH electrodes and instrument are functional together. All subsequent calibrations shall be in accordance with the procedure set forth in 9.5. Refer to Method B in Test Method D1293 for guidelines on the standardization of a pH meter and electrode assembly. Be certain to include the temperature compensator electrode with the pH instrument in the automatic temperature compensation (ATC) mode. Use a quiescent sample of both buffer solutions and laboratory glassware dedicated for this service only. For proper pH calibration buffers, see 8.1 – 8.4. Thoroughly rinse electrodes and glassware with reagent water between each buffer calibration.

9.3 Thoroughly rinse electrodes with reagent water or low ionic strength sample water and reinsert them into the on-line pH sensor flow cell in accordance with the manufacturer's instructions. Permit the pure water sample stream to flush the on-line sensor flow cell and electrode assembly for a minimum of 3 to 4 h at a minimum flow rate of 250 mL/min to remove all traces of the high ionic strength pH buffer solutions.

9.4 Connect the pH electrodes and automatic temperature compensator to the interface module (or on-line pH analyzer if direct coupled) in accordance with the manufacturer's instructions. The output from the signal conditioner goes directly into the on-line pH analyzer/transmitter.

9.5 Performance of subsequent or routine calibration of the on-line pH sensor is accomplished by comparative-sample-testing in accordance with Proposed Test Methods P 228. This procedure will suffice for all future calibration verifications in lieu of the conventional buffer tests of this on-line high purity water pH sensor.

NOTE 4—If the comparative sample temperature is not maintained at 25°C and is not compensated for solution temperature effects, its temperature must be recorded and the proper temperature correction applied. See Appendix X2 for a discussion of temperature effects on pH measurements.

NOTE 5—Periodic confirmation of the calibration of the temperature probe in the on-line pH sensor should be verified with a two point temperature calibration in accordance with the manufacturer's instructions.

NOTE 6—Subsequent verification of the pH glass measurement electrode's ability to measure two solutions of different pH values to determine its span, may be accomplished by removal of the pH glass measurement electrode from the on-line sensor flow chamber and perform a two point calibration using the laboratory pH meter with its reference and temperature compensator electrodes. Follow the procedure described in 9.2 and 9.3. However, this is not a substitute for calibration.

9.6 For power plant users, an alternate method of calibration may be considered which provides for the regular measurement



of certifiable standards. This test method employs the use of a standard sample synthesizer (SSS) (15) that provides a separate quality control (QC) test for the on-line pH instrumentation. In general, an assayed, low conductivity standard solution is injected continuously by a chemical metering pump into a flow of reagent water which was held at a constant, measured rate. As shown in Fig. 3, this very high quality reagent water is prepared from steam condensate by passage of the condensate through a deoxygenation exchange bed, a carbon bed, a mixed bed deionizer, and finally, a 0.2 µm micropure filter. The output from the SSS is routed to the on-line pH sensor assembly under test, just as the plant sample would be. When the continuous pH instrumentation indicates a stable readout, the pH instrument is calibrated to the known value of the standard solution. Two separate low conductivity standard solutions which bracket the pH point of interest should be selected for this procedure.

NOTE 7—Standard solutions within the pH range of interest should be prepared for use in the SSS. A suggested standard solution is prepared from ammonium hydroxide and reagent water for pH values ranging from 8.655 to 9.565 pH. Refer to Table 4 for the pH and specific conductivity values at 25°C of the standard solution for concentrations of ammonium hydroxide (NH<sub>4</sub>OH) ranging from 0.21 mg/L to 4.11 mg/L.

### 10. Procedure

10.1 Install a sample system manifold as shown in Fig. 2, and utilize all the components as indicated in the equipment schedule. All wetted materials should consist of stainless steel (316 or electropolished 304), glass, PTFE, and ceramic. Use of dissimilar metals should be avoided to prevent galvanic corrosion of these metals. Galvanic corrosion develops EMF potentials in the sample stream resulting in observable pH measurement errors. A discussion of contaminants in sample systems is presented in X2.1.

NOTE 8—PTFE is not suitable for radioactive samples and suitable materials should be substituted for all PTFE components in the radiation areas.

10.2 Flush all wetted components of the sample system manifold at 250 mL/min with water or low ionic strength sample water for 3 to 4 h, especially if on-line pH sensor assembly has been exposed to pH calibration buffers or other high ionic strength solutions.

10.3 Maintain sample stream flow rates at a fixed rate according to the manufacturer's recommendation. Sample stream inlet pressure should be maintained at a gage pressure of 345 kPa (50 psig). It is important to maintain both the sample stream flow rate and pressure at fixed levels to prevent pH signal drift and noise resulting from electrode sensitivities to variations in these two parameters and to achieve repeatability of the pH electrode output signal. Determination of the sample line flow rate for a given installation will depend on variables such as total length of sample line and its effect on representative sampling and lag times, size, and age of existing sample lines, and upstream sample pressure and temperature conditioning. A discussion on sample stream flow rates is presented in X2.2.

10.4 Maintain sample stream temperature at 25 ± 1°C. For more information, refer to 6.4. A discussion of sample stream temperature conditioning is presented in X2.3.

10.5 Install the on-line sensor in accordance with the manufacturer's instructions. The design feature(s) of the high purity pH sensor flow cell, that reduces the possibility of air or gas entrapment, or both, within the flow cell, should not be altered. The stainless steel flow cell should be mounted and connected in accordance with the manufacturer's recommendations.

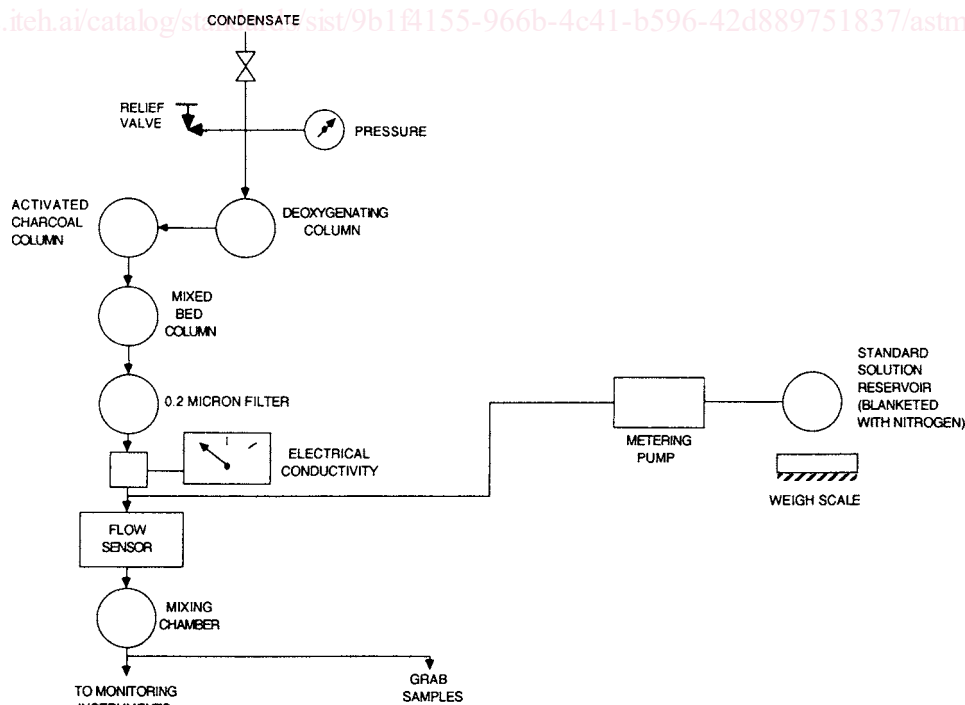

FIG. 3 Standard Synthesizer—Schematic Arrangement

10.6 Connect the pH signal output of the high purity water pH sensor to the pH signal input of the on-line pH analyzer/transmitter in accordance with the manufacturers instructions.

10.7 After completion of the calibration procedures in 9.2 to 9.5, record data continuously or manually until the run is completed.

### 11. Precision and Bias

11.1 Neither precision nor bias data can be obtained for this test method from a collaborative study designed in accordance

with the requirements of Practice D2777 since this test method is a continuous determination. This inability of D2777 procedures to obtain precision and bias data for continuous determinations is recognized and stated in the scope of Practice D2777.

### 12. Keywords

12.1 high purity; low conductivity; on-line; pH

## APPENDIXES

### X1. EFFECTS OF CO<sub>2</sub> ON PH MEASUREMENTS OF HIGH PURITY WATER

X1.1 High purity water will rapidly absorb carbon dioxide when exposed to the atmosphere. Carbon dioxide levels in the atmosphere are slightly greater than 300 mg/L. Pure water by definition does not contain carbon dioxide. However, in practice CO<sub>2</sub> is present in trace to very low levels in most low conductivity water samples. High purity water on-line pH sensor assemblies and related sample system hardware should be designed and installed in such a manner as to prevent the intrusion of carbon dioxide from the atmosphere. See Fig. X1.1

for the theoretical pH and conductivity values of ammonia solutions at various carbon dioxide levels. Also see Table 3 for the theoretical pH shift caused by 0.2 mg/L CO<sub>2</sub> contamination of a high purity water sample. This information is provided to give the user an indication of the level of pH measurement error introduced by the presence of CO<sub>2</sub>. The user should determine the actual effects of CO<sub>2</sub> contamination for the user's specific operating conditions as they may differ from application to application.

(<https://standards.iteh.ai>)  
Document Preview

[ASTM D5128-09](#)

<https://standards.iteh.ai/catalog/standards/sist/9b1f4155-966b-4c41-b596-42d889751837/astm-d5128-09>