



**SLOVENSKI STANDARD**  
**SIST EN 12889:2000**

**01-november-2000**

---

**Izvedba in preskušanje kanalov in drenaž brez izkopa**

Trenchless construction and testing of drains and sewers

Grabenlose Verlegung und Prüfung von Abwasserleitungen und -kanälen

Mise en oeuvre sans tranchée et essai des branchements et collecteurs  
d'assainissement

**(standards.iteh.ai)**

**Ta slovenski standard je istoveten z: EN 12889:2000**

<https://standards.iteh.ai/catalog/standards/sist/c29c3d20-363a-4fd9-b401-a69c3741de05/sist-en-12889-2000>

**ICS:**

93.030      Zunanji sistemi za odpadno      External sewage systems  
vodo

**SIST EN 12889:2000**

**en**

**iTeh STANDARD PREVIEW**  
**(standards.iteh.ai)**

SIST EN 12889:2000

<https://standards.iteh.ai/catalog/standards/sist/c29c3d20-363a-4fd9-b401-a69c3741de05/sist-en-12889-2000>

EUROPEAN STANDARD  
NORME EUROPÉENNE  
EUROPÄISCHE NORM

EN 12889

January 2000

ICS 93.030

English version

Trenchless construction and testing of drains and sewers

Mise en oeuvre sans tranchée et essai des branchements  
et collecteurs d'assainissement

Grabenlose Verlegung und Prüfung von Abwasserleitungen  
und -kanälen

This European Standard was approved by CEN on 15 November 1999.

CEN members are bound to comply with the CEN/CENELEC Internal Regulations which stipulate the conditions for giving this European Standard the status of a national standard without any alteration. Up-to-date lists and bibliographical references concerning such national standards may be obtained on application to the Central Secretariat or to any CEN member.

This European Standard exists in three official versions (English, French, German). A version in any other language made by translation under the responsibility of a CEN member into its own language and notified to the Central Secretariat has the same status as the official versions.

CEN members are the national standards bodies of Austria, Belgium, Czech Republic, Denmark, Finland, France, Germany, Greece, Iceland, Ireland, Italy, Luxembourg, Netherlands, Norway, Portugal, Spain, Sweden, Switzerland and United Kingdom.

**(standards.iteh.ai)**

SIST EN 12889:2000

<https://standards.iteh.ai/catalog/standards/sist/c29c3d20-363a-4fd9-b401-a69c3741de05/sist-en-12889-2000>



EUROPEAN COMMITTEE FOR STANDARDIZATION  
COMITÉ EUROPÉEN DE NORMALISATION  
EUROPÄISCHES KOMITEE FÜR NORMUNG

Central Secretariat: rue de Stassart, 36 B-1050 Brussels

## Contents

|   | Page |
|---|------|
| <b>Foreword</b> .....   | 3    |
| <b>1 Scope</b> .....  | 4    |
| <b>2 Normative references</b> .....   | 4    |
| <b>3 Definitions</b> .....  | 4    |
| <b>4 General</b> .....  | 5    |
| <b>5 Construction components and materials</b> .....  | 5    |
| 5.1 General .....   | 5    |
| 5.2 Pipes and joints .....  | 5    |
| 5.3 Manholes and inspection chambers .....  | 5    |
| 5.4 Delivery, handling and transportation on site .....   | 5    |
| 5.5 Storage .....   | 5    |
| <b>6 Techniques</b> .....   | 6    |
| 6.1 Unmanned techniques .....   | 8    |
| 6.2 Manned techniques .....   | 15   |
| <b>7 Requirements</b> .....   | 16   |
| 7.1 Safeguarding design assumptions .....   | 16   |
| 7.2 Special requirements .....  | 16   |
| 7.3 Safeguarding design assumptions .....   | 16   |
| 7.4 Information about ground conditions .....   | 16   |
| 7.5 Data collection during installation .....   | 17   |
| 7.6 Stability during construction .....   | 18   |
| 7.7 Overcut .....   | 18   |
| 7.8 Overbreak .....   | 18   |
| 7.9 Settlement and heave .....  | 18   |
| 7.10 Deviation in line and level .....  | 18   |
| <b>8 Inspection and/or testing of pipelines after installation</b> .....  | 19   |
| 8.1 Visual inspection .....   | 19   |
| 8.2 Leaktightness .....   | 19   |
| <b>9 Procedures and requirements for testing gravity pipelines</b> .....  | 19   |
| 9.1 General .....   | 19   |
| 9.2 Testing with air (method "L") .....   | 19   |
| 9.3 Testing with water (method "W") .....   | 22   |
| 9.4 Testing of each individual joint .....  | 22   |
| <b>10 Testing of pressure pipelines</b> .....   | 22   |
| <b>11 Qualification</b> .....   | 22   |
| <b>Annex A (informative) Abstract from Council Directive of 17 September 1990 on the procurement procedures of entities operating in the water, energy, transport and telecommunication sectors</b> ..... | 23   |

## Foreword

This European Standard has been prepared by Technical Committee CEN/TC 165 "Waste water engineering", the secretariat of which is held by DIN.

This European Standard shall be given the status of a national standard, either by publication of an identical text or by endorsement, at the latest by July 2000, and conflicting national standards shall be withdrawn at the latest by July 2000.

According to the CEN/CENELEC Internal Regulations, the national standards organizations of the following This European Standard has countries are bound to implement this European Standard: Austria, Belgium, Czech Republic, Denmark, Finland, France, Germany, Greece, Iceland, Ireland, Italy, Luxembourg, Netherlands, Norway, Portugal, Spain, Sweden, Switzerland and the United Kingdom.

Annex A is informative.

## iTeh STANDARD PREVIEW (standards.iteh.ai)

SIST EN 12889:2000

<https://standards.iteh.ai/catalog/standards/sist/c29c3d20-363a-4fd9-b401-a69c3741de05/sist-en-12889-2000>

## 1 Scope

This European Standard is applicable to the trenchless construction and testing of new drains and new sewers in the ground, which are normally operating as gravity pipelines, formed using prefabricated pipes and their joints. The trenchless construction and testing of drains and sewers operating under pressure is also covered by this European Standard together with prEN 805:1999 as appropriate.

This European Standard also applies to trenchless replacement techniques. Renovation techniques for existing sewers and drains are not covered by this European Standard.

Methods of trenchless construction include

- manned and unmanned techniques;
- steerable and non-steerable techniques.

NOTE 1: Mining or tunnelling (e.g. in situ construction or the use of prefabricated segments) are not covered by this European Standard although some parts may apply to these methods. Additional requirements apply for mining and tunnelling methods for the construction of drains and sewers.

Additionally other local or national regulations should be taken into account, e.g. concerning health and safety, pavement installation, tolerances for deviation in line and level and requirements for leaktightness testing.

NOTE 2: Requirements for associated pipeline installation work other than trenchless construction, e. g. for manholes and inspection chambers, are given in EN 1610 'Construction and testing of drains and sewers'.

## 2 Normative references

This European Standard incorporates by dated or undated reference, provisions from other publications. These normative references are cited at the appropriate places in the text and the publications are listed hereafter. For dated references, subsequent amendments to or revisions of any of these publications apply to this European Standard only when incorporated in it by amendment or revision. For undated references the latest edition of the publication referred to applies.

EN 752-5 : 1997

Drain and sewer systems outside buildings – Part 5: Rehabilitation

prEN 805:1999

Water supply – Requirements for systems and components outside buildings

## 3 Definitions

For the purposes of this European Standard the following definitions apply:

- 3.1 Cutting head:** A tool or system of tools on a common support, which excavates at the face of a bore. The term usually applies to mechanical methods of excavation.
- 3.2 Expander:** A tool which enlarges a bore by displacement of the surrounding ground rather than by excavation.
- 3.3 Gravity pipeline:** Pipeline where flow is caused by the force of gravity and where the pipeline is designed normally to operate partially full.
- 3.4 Overbreak:** The extent by which the excavated void including accidental ground losses initially exceeds the outside dimension of the pipe.
- 3.5 Overcut:** The annular space around the pipe deliberately created by using a cutting head or shield of greater dimension than the outside dimension of the pipe.
- 3.6 Pipe jacking:** A system of directly installing pipes behind a cutting head and/or shield, by hydraulic jacking from a drive shaft, such that the pipes form a string in the ground.
- 3.7 Reamer:** A cutting head attached to the end of a drill string or pilot rod to enlarge the pilot diameter during a pull-back or pushing operation, to enable a pipe or pipes to be installed.
- 3.8 Renovation:** Work incorporating all or part of the original fabric of the pipeline by means of which its current performance is improved (EN 752-5 : 1997).
- 3.9 Replacement:** Construction of a new drain or sewer, on or off the line of an existing drain or sewer, the function of the new drain or sewer incorporating that of the old (EN 752-5 : 1997).

**3.10 Spoil:** Material excavated and removed in the course of installation.

**3.11 Trenchless construction technique:** Any technique for constructing pipelines in the ground without opening trenches.

**3.12 Manned technique:** Technique involving the use of personnel working in the excavated bore during installation.

**3.13 Unmanned technique:** Technique avoiding the use of personnel working in the excavated bore during installation.

## 4 General

Pipelines, manholes and inspection chambers are essentially engineering structures in which the combined performance of construction components, bedding, and fill or the surrounding ground constitute the basis for stability and safety in operation. The pipes, fittings and components for jointing supplied, together with the work carried out at site, are all important factors in achieving a structure with adequate performance.

## 5 Construction components and materials

### 5.1 General

Construction components and materials shall conform to national standards, transposing European Standards as available, or to European technical approvals, or, in the absence of these, the components and materials shall comply with the requirements of the specifier.

Any supplementary instructions of the manufacturer shall be observed.

### 5.2 Pipes and joints

Installation shall not commence before the following criteria have been agreed between the specifier and installer. These may be obtained from appropriate product standards or from the pipe manufacturer:

- internal pipe diameter;
- external pipe diameter;
- pipe length;
- tolerances on dimensions;
- safe jacking load or pulling force;
- type and performance of joints;
- longitudinal flexibility (acceptable bending radius or angular deflection).

### 5.3 Manholes and inspection chambers

Manholes and inspection chambers shall be in accordance with product standards or appropriate specifications.

### 5.4 Delivery, handling and transportation on site

Pipes, pipeline components and jointing accessories shall be inspected on delivery to ensure that they are appropriately marked and comply with the design requirements.

Any instructions from the manufacturer shall be adhered to.

Products shall be examined both on delivery and immediately prior to installation to ensure that they are free from damage.

### 5.5 Storage

Any instructions from the manufacturer and the requirements of the appropriate product standards shall be adhered to.

All materials should be stored in such a manner to keep them clean and avoid contamination or degradation, for example elastomeric jointing components should be kept clean and be protected from sources of ozone (e. g. electrical equipment), sunlight and oil, where necessary.

Pipes shall be secured to prevent rolling. Excessive stacking heights should be avoided so that pipes in the lower part of the stacks are not overloaded. Stacks of pipes shall not be placed close to open trenches.

Pipes with protective coatings shall be stored where necessary, on supports which keep them clear of the ground to avoid damage to coatings and joints. All pipes should be stored on supports in very cold weather to avoid freezing to the ground.

## 6 Techniques

A schematic classification of trenchless techniques is given in Figure 1, representing techniques available at the time of publication of this European Standard.

**iTeh STANDARD PREVIEW**  
**(standards.iteh.ai)**

SIST EN 12889:2000

<https://standards.iteh.ai/catalog/standards/sist/c29c3d20-363a-4fd9-b401-a69c3741de05/sist-en-12889-2000>



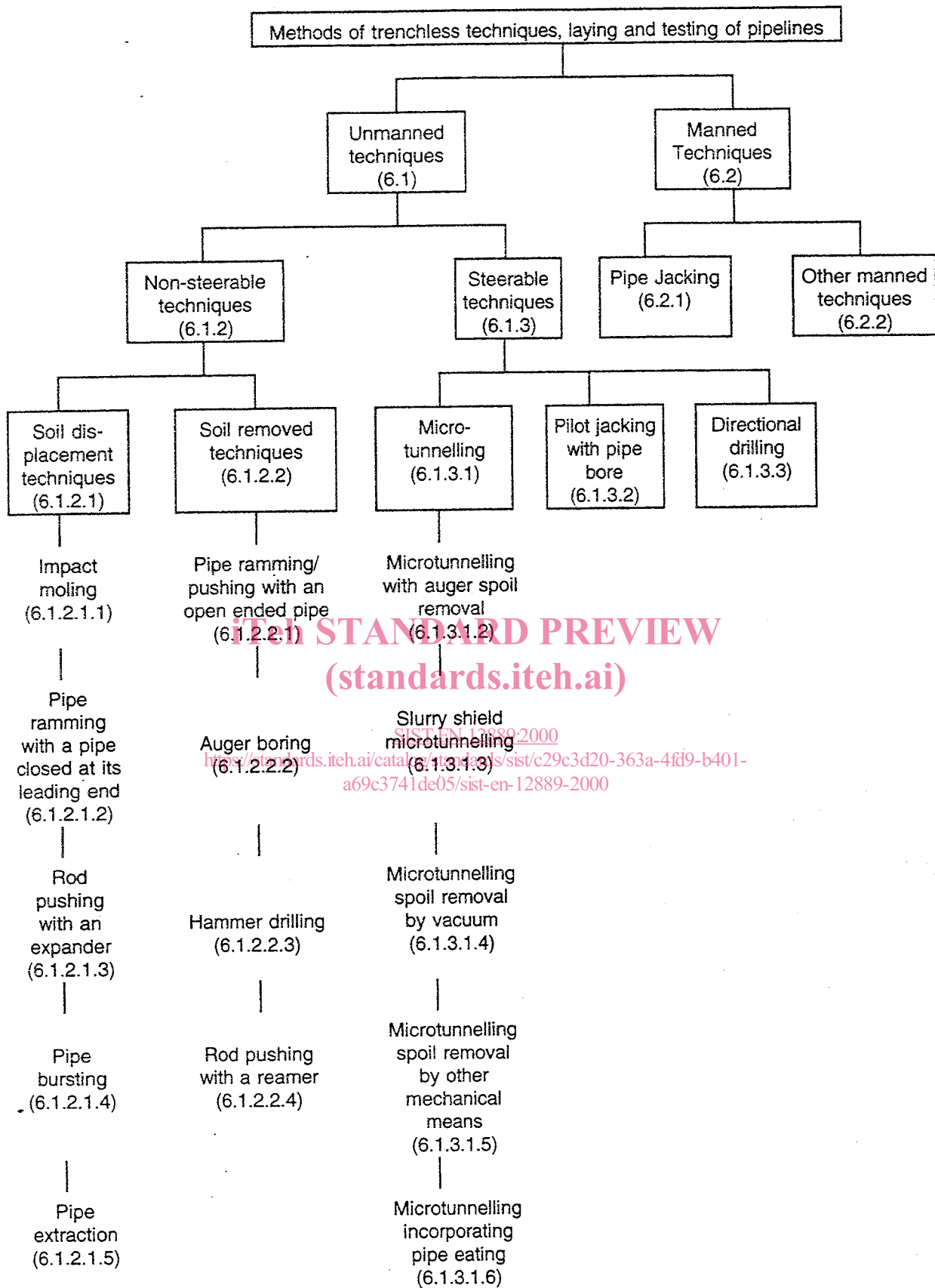

Figure 1: Trenchless techniques

## 6.1 Unmanned techniques

Pipes are installed with the aid of percussive, vibrating or steadily applied forces, through the ground, from an entry shaft or other access to an exit shaft or other reception point. The soil is displaced or removed from the face.

### 6.1.1 General

Systems may be non-steerable or steerable.

The choice of technique will depend on the following factors:

- accuracy required in line and level;
- proximity of other services;
- external diameter;
- length to be driven;
- ground conditions;
- groundwater conditions and
- minimum depth of cover.

### 6.1.2 Non-steerable techniques

Accuracy of alignment of a non-steerable technique is influenced by the properties of the ground (especially inclusions and stratification) and the driven length. Therefore these techniques are limited to the installation of pipelines which do not require precise alignment. Special precautions are required to avoid damage to other structures and underground services.

#### 6.1.2.1 Soil displacement techniques

##### 6.1.2.1.1 Impact moling

Impact moling uses a tool which comprises a percussive hammer within a casing, generally a cylinder with tapered nose or stepped head which travels through the ground (see Figure 2). The hammer can be pneumatic or hydraulic. Its forward movement displaces the soil and relies on the frictional resistance of the ground. A pipe is pulled or pushed either immediately behind the impact moling tool or through an unsupported bore which may be formed in suitable ground.

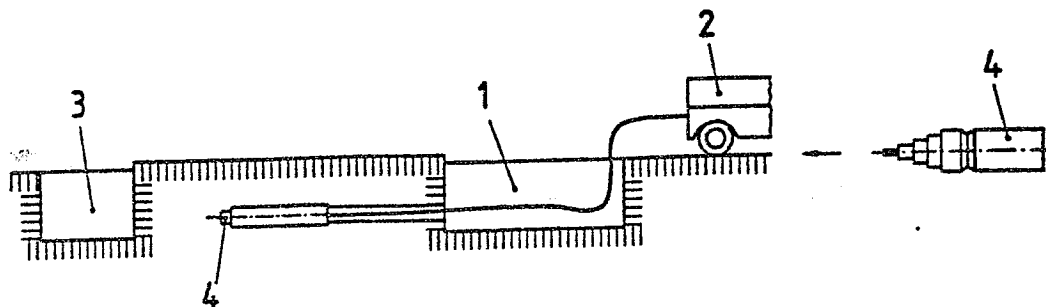

- 1 Entry shaft
- 2 Hydraulic pump/air compressor
- 3 Exit shaft
- 4 Percussive hammer

Figure 2: Example of impact moling

### 6.1.2.1.2 Pipe ramming with a pipe closed at its leading end

Pipe ramming with a pipe closed at its leading end is a technique of forming a bore by driving a steel casing with a closed end using a percussive hammer (see Figure 3). The ground is displaced by the closed end.

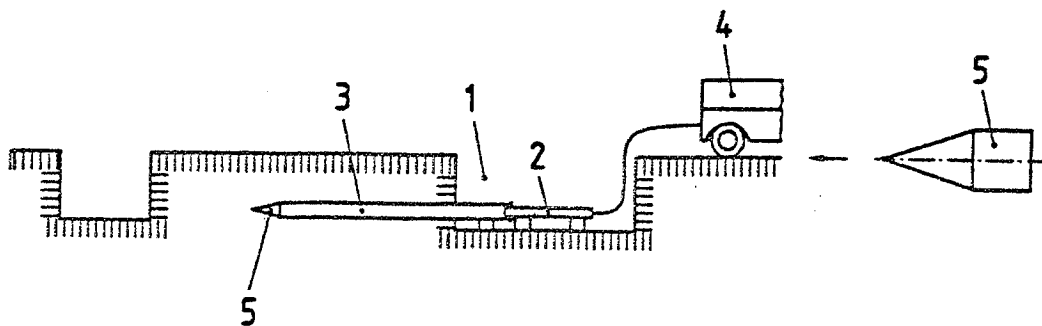

- 1 Entry shaft
- 2 Ram system
- 3 Pipe closed at its leading end
- 4 Hydraulic pump/air compressor
- 5 Closed leading end of pipe

Figure 3: Example of pipe ramming with a pipe closed at its leading end

### 6.1.2.1.3 Rod pushing with an expander

Ground is displaced by pushing a rigid pilot rod. The final pipeline is installed by pulling or pushing behind an expander (see Figure 4).

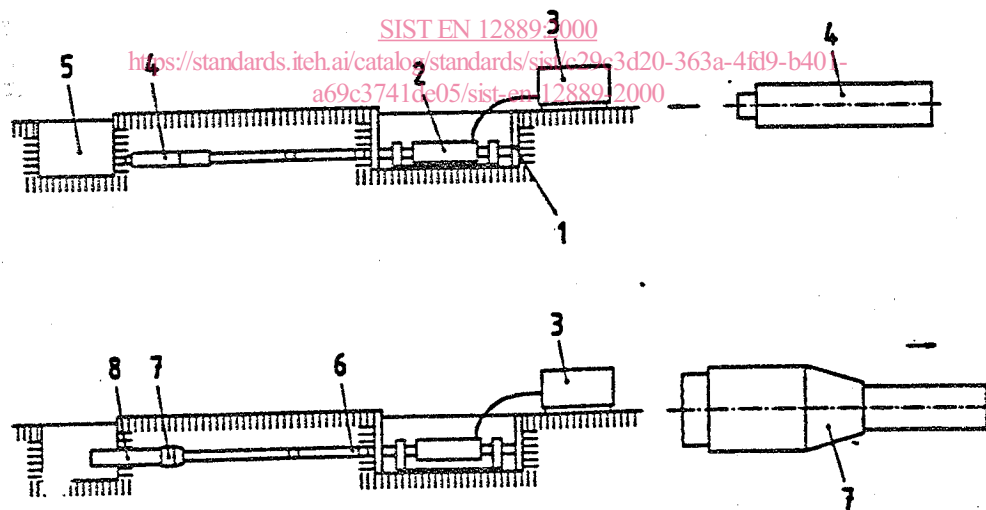

- 1 Entry shaft
- 2 Ram system
- 3 Hydraulic pump
- 4 Pilot rod
- 5 Exit shaft
- 6 Rod
- 7 Expander
- 8 Pipe

Figure 4: Example of rod pushing with an expander