



Designation: E 285 – 80 (Reapproved 2002)

Standard Test Method for Oxyacetylene Ablation Testing of Thermal Insulation Materials¹

This standard is issued under the fixed designation E 285; the number immediately following the designation indicates the year of original adoption or, in the case of revision, the year of last revision. A number in parentheses indicates the year of last reapproval. A superscript epsilon (ϵ) indicates an editorial change since the last revision or reapproval.

1. Scope

1.1 This test method covers the screening of ablative materials to determine the relative thermal insulation effectiveness when tested as a flat panel in an environment of a steady flow of hot gas provided by an oxyacetylene burner.

1.2 This test method should be used to measure and describe the properties of materials, products, or assemblies in response to heat and flame under controlled laboratory conditions and should not be used to describe or appraise the fire hazard of materials, products, or assemblies under actual fire conditions. However, results of this test method may be used as elements of a fire risk assessment which takes into account all of the factors which are pertinent to an assessment of the fire hazard of a particular end use.

1.3 *This standard does not purport to address all of the safety concerns, if any, associated with its use. It is the responsibility of the user of this standard to establish appropriate safety and health practices and determine the applicability of regulatory limitations prior to use.*

1.4 The values stated in SI units are to be regarded as the standard.

2. Referenced Documents

2.1 ASTM Standards:

D 792 Test Methods for Density and Specific Gravity (Relative Density) of Plastics by Displacement²

2.2 Federal Standards:³

BB-A-106a Acetylene, Technical, Dissolved

BB-O-925a Oxygen, Technical, Gas and Liquid

¹ This test method is under the jurisdiction of ASTM Committee E21 on Space Simulation and Applications of Space Technology and is the direct responsibility of Subcommittee E21.08 on Thermal Protection.

Current edition approved Dec. 8, 1980. Published February 1981. Originally published as E 285 – 65T. Last previous edition E 285 – 70.

² *Annual Book of ASTM Standards*, Vol 08.01.

³ Available from Standardization Documents Order Desk, Bldg. 4 Section D, 700 Robbins Ave., Philadelphia, PA 19111-5098, Attn: NPODS.

3. Summary of Test Method

3.1 Hot combustion gases are directed along the normal to the specimen until burn-through is achieved. The erosion rate of the material is determined by dividing the original thickness by the time to burn-through. The insulating effectiveness is determined from back-face temperature measurements. Insulation index numbers are computed by dividing the times for temperature changes of 80, 180, and 380°C, from the initial ambient temperature, by the original thickness. The insulation-to-density performance is computed by dividing the insulation index by the density of the panel.

3.2 The general characteristics of the oxyacetylene heat source are:

3.2.1 *Heat Flux*—835 W/cm² (cold-wall calorimeter).

3.2.2 *Velocity*—210 m/s (cold, unreacted gases).

3.2.3 Neutral flame conditions.

4. Significance and Use

4.1 This test method is intended to screen the most obvious poor materials from further consideration. Since the combustion gases more closely resemble the environment generated in rocket motors, this test method is more applicable to screening materials for nozzles and motor liners than for aerodynamic heating.

4.2 The environment for any specific high-temperature thermal protection problem is peculiar to that particular application. The conditions generated by the oxyacetylene heat source in this test method represent only one set of conditions; they do not simulate any specific application. Thus, the test results cannot be used to predict directly the behavior of materials for specific environments, nor can they be used for design purposes. However, over a number of years, the test has been useful in determining the relative merit of materials, particularly in weeding out obviously poor materials from more advanced data-generation programs. It has also been considered for use as a production quality-control test for rocket insulation materials.

4.3 The tester is cautioned to use prudence in extending the usefulness of the test method beyond its original intent, namely, screening. For situations having environments widely different from those of the test, the user is urged to modify the oxyacetylene burner conditions to suit his requirements or perhaps change to a different heat-generating device that provides better simulation.

5. Apparatus

5.1 *General*—The apparatus shall consist of an oxyacetylene burner, a specimen holder, and means for measuring the time to burn-through and for recording the back-face temperature history of the specimen. Auxiliary apparatus all consist of a calorimetric device to measure heat-transfer rate as specified in 5.5.

5.2 *Heat Source*—The hot-gas source shall consist of a welding torch with suitable storage for acetylene and oxygen, together with suitable manifolds, flow regulators, and flow and pressure indicators, as shown schematically in Fig. 1.

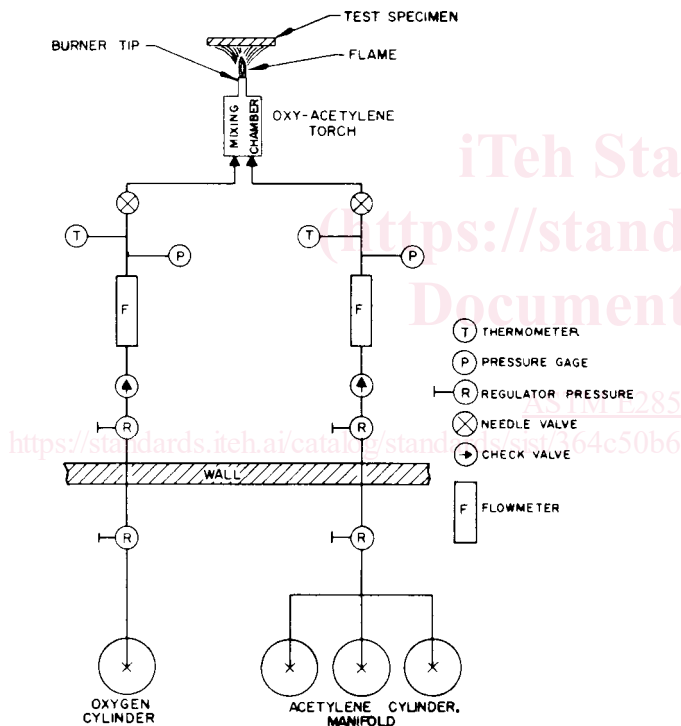

FIG. 1 Schematic Diagram of Gas System

5.2.1 *Torch*—The torch shall be a Victor Model 315⁴ and shall be mounted so that the flame can be made to contact the specimen in less than 1/2 s from the time of actuation.

NOTE 1—Both a solenoid-powered mechanism and a hand-operated system of levers and push rods have been found to be adequate for this purpose.

5.2.2 *Torch Tip*—The tip shall be a Victor welding nozzle, Type 4, No. 7, equipped with a water jacket to minimize

damage to the tip (Note 2).⁴ Details of the water jacket are shown in Figs. 2 and 3 and the torch tip is shown in Fig. 4.

NOTE 2—Proprietary designation cannot be avoided because of the broad spectrum of heat flux and flame patterns produced by competitive torch tips of similar size. The Victor torch tip was selected on the basis of popularity, reproducibility of test results, and the relatively high heat flux it produces.

5.2.3 *Fuel Storage and Manifold*—A minimum of three acetylene cylinders shall be tapped simultaneously through a manifold and suitable pressure regulators. Cylinders shall be stored in an upright position and held at room temperature for at least 1 h, or until at equilibrium with room temperature, before using. The complete bank of cylinders shall be changed when the gage reads 0.7 MPa (100 psi). Acetylene storage tanks shall be protected by a check valve against accidental backflow from the torch. The acetylene shall be maintained at 294.2 K (70°F) when possible (Note 3). The purity of acetylene gas shall conform with Federal Specification BB-A-106a. The minimum acetylene content shall be 98 %.

NOTE 3—If this is not possible, the flow rate shall be corrected to 294.2 K in accordance with the flow rate specified in 5.2.7. The gas temperature shall not be allowed to exceed 299 K (79°F) or go below 289 K (61°F). Flow rates are corrected to 294.2 K because most manufacturers use this temperature as standard for calibration charts.

5.2.4 *Oxygen Storage*—A minimum of one oxygen tank shall be tapped through suitable pressure regulators. The oxygen shall be maintained at 294.2 K when possible (Note 4). The purity of oxygen gas shall conform with Federal Specification BB-O-925a. The minimum oxygen content shall be 99.5 %.

5.2.5 *Safety Wall*—The acetylene and oxygen storage area shall be isolated from the torch and the operating area by a suitable safety wall. For convenience, a two-stage regulator shall be located in the storage space and a single-stage pressure regulator located in the operating area.

5.2.6 *Pressure Regulators*—The regulators for the oxygen and the acetylene shall be capable of supplying the flow of gases specified in 5.2.7.

5.2.7 *Flowmeters*—The flowmeters for the acetylene and the oxygen shall be capable of supplying an accurate flow of gases.⁵ A variation of ±5 % in gas flow rate due to instrumentation inaccuracies shall be permissible. The total flow rate of unreacted gases shall be 6.37 standard m³/h (294.2 K, 0.1 MPa) (225 standard ft³/h (70.0°F, 14.7 psia)), and the volume ratio of oxygen to acetylene shall be 1.20, which corresponds to essentially a neutral (oxygen-free) atmosphere.

NOTE 4—Flowmeter and pressure-gage settings are not specified because they will vary with the size and brand of flowmeter used. Consult manufacturers' instructions and calibration charts that are furnished with the flowmeters.

5.2.8 *Flow-Pressure Gages*—Suitable pressure gages shall be located at the exit (downstream) side of the flowmeters to monitor metered gas pressure. These gages shall be capable of supplying pressure measurements to maintain an accurate flow of gases in accordance with the specifications stated in 5.2.7.

⁵ Fischer-Porter Meter size 4, Fig. 1735, float shape BSVT, equivalent capacity 3.35 standard ft³/min air, has been found satisfactory for this purpose.

⁴ Victor Equipment Co., 2800 Airport Rd., Denton, TX 76207.

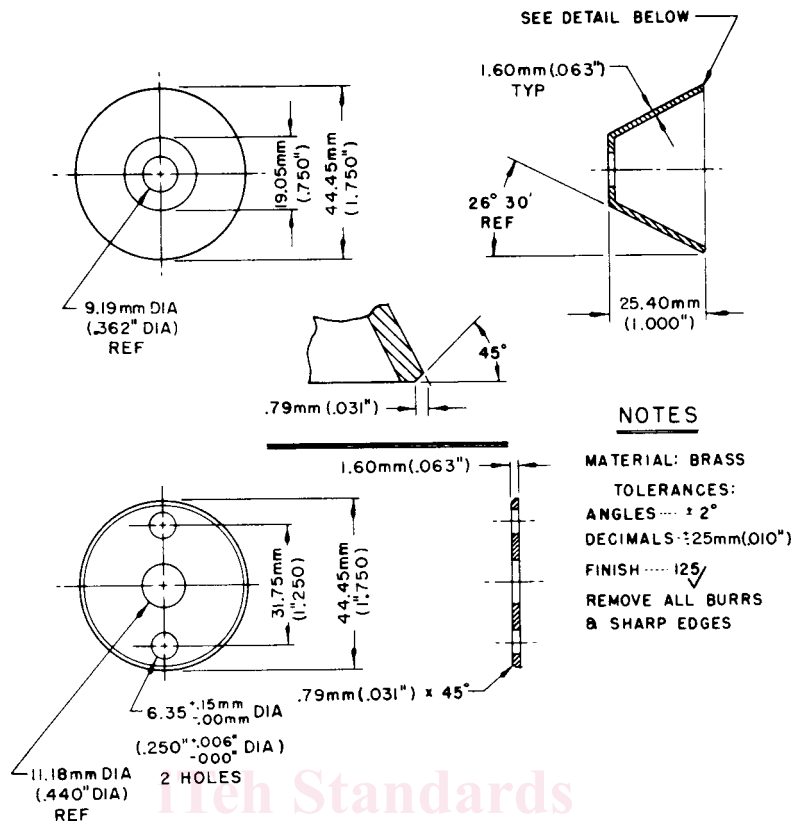

FIG. 2 Details of Water Jacket for Oxyacetylene Torch

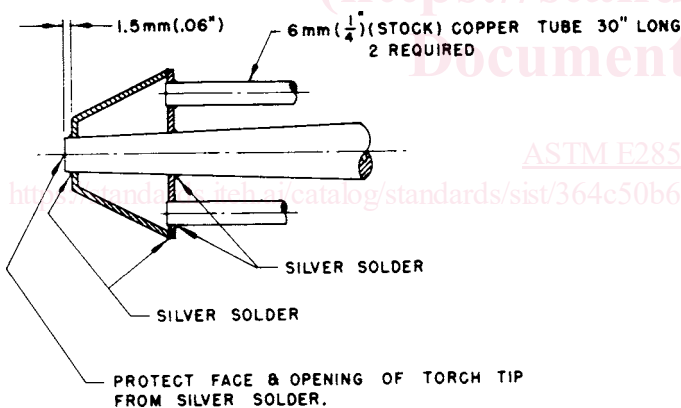

FIG. 3 Assembly of Water Jacket for Oxyacetylene Torch

NOTE 5—Pressure gages graduated 0 to 50 psig for oxygen and 0 to 30 psig for acetylene, both in 1-psig increments, have been found to be suitable.

5.2.9 *Temperature-Measuring Devices*—Gas temperatures shall be measured with thermocouples, thermistors, or other suitable devices located at the exit (downstream) side of the flowmeters. Accuracy shall be within ± 1.0 K (± 1.8 F).

5.2.10 *Piping, Hoses, and Needle Valves*—Any combination of piping, tubing, hoses, and needle valves may be employed that have sufficient flow capacity to allow the fuel and oxidant to flow and be controlled at the specified flow rates.

5.3 *Specimen Holder*—The specimen and the calorimeter shall be supported in a suitable fixture arranged in such a

fashion that it can be moved to align and set the distance and angle (see 8.4 for specifications) between the specimen, or calorimeter, and the torch tip (Note 7). The back surface of the specimen shall be unobstructed by the holder for a distance of 25.4 mm (1.00 in.) out from the center of the specimen. Only materials with a thermal conductivity of 0.2 W/m·K (1.4 Btu·in./h·ft²·°F) or less shall contact the back of the specimen. The front surface of the specimen shall be unobstructed for a distance of 48.0 mm (1.89 in.) out from the center of the specimen. The total area of contact with front and back surfaces shall not exceed 52.0 cm² (8.06 in.²).

NOTE 6—A lathe bed with the specimen holder mounted on the tool carriage has been found to be adequate for the purpose. Water cooling of the holder is recommended to prolong service life.

5.4 *Back-Face Temperature Measurement*—The back-face temperature history shall be measured with a No. 28 AWG gage Chromel-Alumel thermocouple.

NOTE 7—For soft specimens, it shall be permissible to attach a thin copper disk, no larger than 10 mm (0.39 in.) in diameter, to the thermocouple junction.

5.4.1 *Thermocouple Mounting*—A spring-loaded, two-hole ceramic support rod no larger than 3.2 mm (1/8 in.) in diameter shall be used to maintain good contact between the thermocouple and the back surface of the specimen.

5.4.2 *Temperature Recorder*—The thermocouple emf shall be recorded as back-face temperature, in degrees Celsius, as a function of time during the test. The response time of the recorder shall be 1 s or less for full-scale deflection and the chart speed shall be at least 12 m/s (approximately 8 in./min).