



SLOVENSKI STANDARD
SIST EN ISO 80369-3:2016/oprA1:2022

01-oktober-2022

**Priključki z majhnim premerom za tekočine in pline za uporabo v zdravstvu - 3. del:
Priključki za enteralno uporabo - Dopolnilo A1 (ISO 80369-3:2016/Amd 1:2019)**

Small-bore connectors for liquids and gases in healthcare applications - Part 3:
Connectors for enteral applications - Amendment 1 (ISO 80369-3:2016/Amd 1:2019)

Verbindungsstücke mit kleinem Durchmesser für Flüssigkeiten und Gase in
medizinischen Anwendungen - Teil 3: Verbindungsstücke für enterale Anwendungen -
Änderung 1 (ISO 80369-3:2016/Amd 1:2019)

Raccords de petite taille pour liquides et gaz utilisés dans le domaine de la santé - Partie
3: Raccords destinés à des applications entérales - Amendement 1 (ISO 80369-
3:2016/Amd 1:2019)

Ta slovenski standard je istoveten z: EN ISO 80369-3:2016/prA1

ICS:

| | | |
|-----------|-------------------------------------|---------------------------------|
| 11.040.25 | Injekcijske brizge, igle in katetri | Syringes, needles and catheters |
|-----------|-------------------------------------|---------------------------------|

SIST EN ISO 80369-3:2016/oprA1:2022 en,fr,de

INTERNATIONAL
STANDARD

ISO
80369-3

First edition
2016-07-01

AMENDMENT 1
2019-02

**Small-bore connectors for liquids and
gases in healthcare applications —**

Part 3:

Connectors for enteral applications

AMENDMENT 1

iTeh STANDARD PREVIEW
(standards.iteh.ai)

*Raccords de petite taille pour liquides et gaz utilisés dans le domaine
de la santé —*

Partie 3: Raccords destinés à des applications entérales

AMENDEMENT 1

SIST EN ISO 80369-3:2016/oprA1:2022

<https://standards.iteh.ai/catalog/standards/sist/be0d3a77-cabd-4828-82a9-8f0aa6019dfe/sist-en-iso-80369-3-2016-opra1-2022>



Reference number
ISO 80369-3:2016/Amd.1:2019(E)

© ISO 2019

iTeh STANDARD PREVIEW (standards.iteh.ai)

[SIST EN ISO 80369-3:2016/oprA1:2022](https://standards.iteh.ai/catalog/standards/sist/be0d3a77-cabd-4828-82a9-8f0aa6019dfe/sist-en-iso-80369-3-2016-opra1-2022)

<https://standards.iteh.ai/catalog/standards/sist/be0d3a77-cabd-4828-82a9-8f0aa6019dfe/sist-en-iso-80369-3-2016-opra1-2022>



COPYRIGHT PROTECTED DOCUMENT

© ISO 2019

All rights reserved. Unless otherwise specified, or required in the context of its implementation, no part of this publication may be reproduced or utilized otherwise in any form or by any means, electronic or mechanical, including photocopying, or posting on the internet or an intranet, without prior written permission. Permission can be requested from either ISO at the address below or ISO's member body in the country of the requester.

ISO copyright office
CP 401 • Ch. de Blandonnet 8
CH-1214 Vernier, Geneva
Phone: +41 22 749 01 11
Fax: +41 22 749 09 47
Email: copyright@iso.org
Website: www.iso.org

Published in Switzerland

Foreword

ISO (the International Organization for Standardization) is a worldwide federation of national standards bodies (ISO member bodies). The work of preparing International Standards is normally carried out through ISO technical committees. Each member body interested in a subject for which a technical committee has been established has the right to be represented on that committee. International organizations, governmental and non-governmental, in liaison with ISO, also take part in the work. ISO collaborates closely with the International Electrotechnical Commission (IEC) on all matters of electrotechnical standardization.

The procedures used to develop this document and those intended for its further maintenance are described in the ISO/IEC Directives, Part 1. In particular the different approval criteria needed for the different types of ISO documents should be noted. This document was drafted in accordance with the editorial rules of the ISO/IEC Directives, Part 2 (see www.iso.org/directives).

Attention is drawn to the possibility that some of the elements of this document may be the subject of patent rights. ISO shall not be held responsible for identifying any or all such patent rights. Details of any patent rights identified during the development of the document will be in the Introduction and/or on the ISO list of patent declarations received (see www.iso.org/patents).

Any trade name used in this document is information given for the convenience of users and does not constitute an endorsement.

For an explanation on the meaning of ISO specific terms and expressions related to conformity assessment, as well as information about ISO's adherence to the WTO principles in the Technical Barriers to Trade (TBT) see the following URL: [Foreword - Supplementary information](#)

The committee responsible for this document is ISO/TC 210, *Quality management and corresponding general aspects for medical devices*, and IEC/SC 62D, *Electromedical equipment*. The draft was circulated for voting to the national bodies of both ISO and IEC.

A list of all the parts in the ISO 80369 series can be found on the ISO website.

Any feedback or questions on this document should be directed to the user's national standards body. A complete listing of these bodies can be found at www.iso.org/members.html.

Small-bore connectors for liquids and gases in healthcare applications —

Part 3: Connectors for enteral applications

AMENDMENT 1

Scope

Remove the following text from the bulleted list under “This part of ISO 80369 does not specify requirements for SMALL-BORE CONNECTORS that are used for the following:”

“MEDICAL DEVICES for rectal drainage, rectal administration of medicines or fluid, and any other rectal access MEDICAL DEVICE”

Figure B.1

Revise Figure B.1 to add new dimension a_3 and r_3 and add a new NOTE 2.

iTeh STANDARD PREVIEW

(standards.iteh.ai)

[SIST EN ISO 80369-3:2016/oprA1:2022](https://standards.iteh.ai/catalog/standards/sist/be0d3a77-cabd-4828-82a9-8f0aa6019dfe/sist-en-iso-80369-3-2016-opra1-2022)

<https://standards.iteh.ai/catalog/standards/sist/be0d3a77-cabd-4828-82a9-8f0aa6019dfe/sist-en-iso-80369-3-2016-opra1-2022>

ISO 80369-3:2016/Amd.1:2019(E)

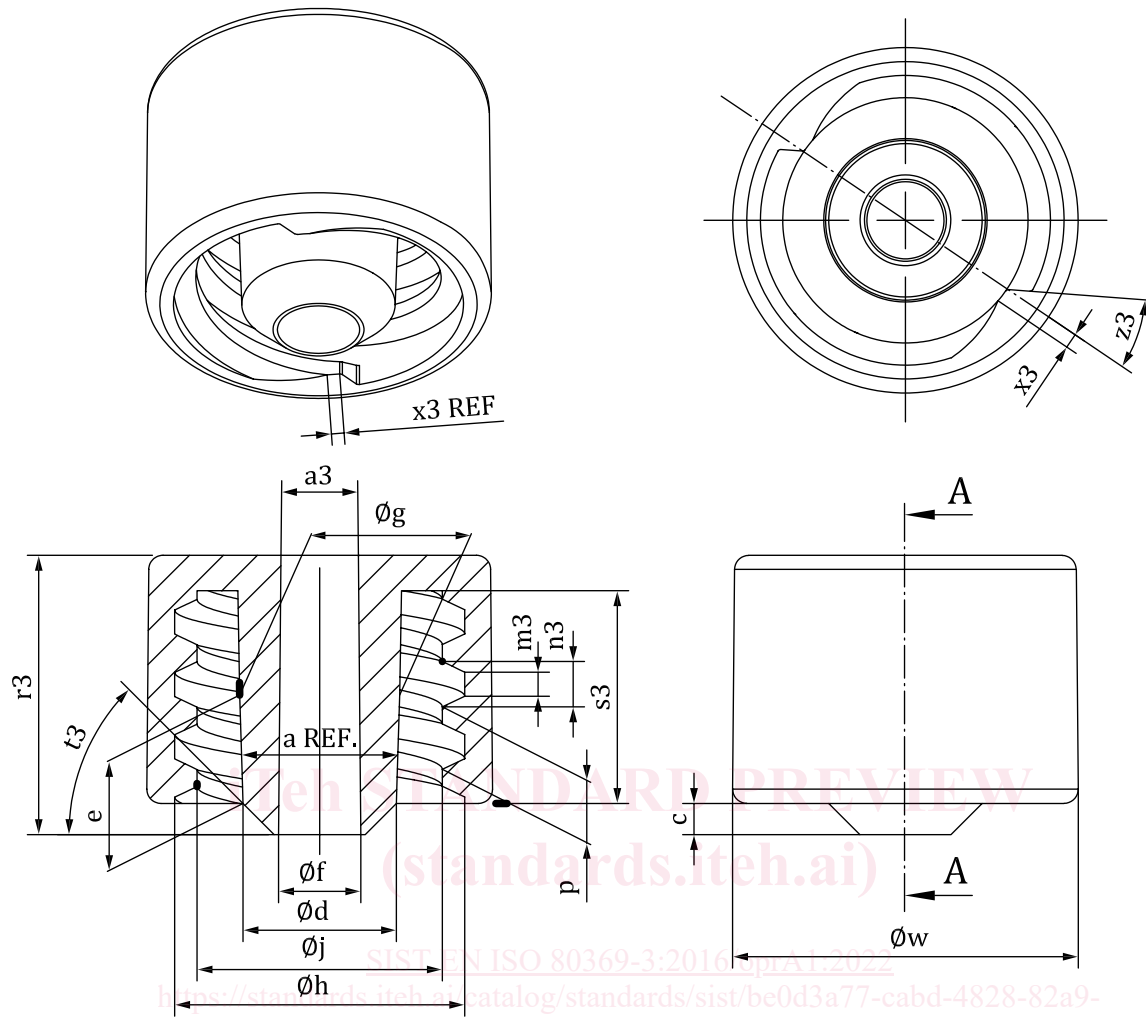

NOTE 1 Table B.1 contains the dimensions for Figure B.1.

NOTE 2 Dimensions a_3 and r_3 start at $\varnothing f$.

Figure B.1 — Male E1 SMALL-BORE CONNECTOR

In Figure B.1, the male ENTERAL SMALL-BORE CONNECTOR may utilize a rotatable collar. The requirements for dimension c shall be maintained.

Table B.1

Revise Table B.1 as follows:

Add superscript "g" to $\varnothing f$.

Add a footnote "g" applicable to designations $\varnothing f$, a_3 and r_3 , "A minimum diameter of 2,85 for $\varnothing f$, a maximum angle of 2° for a_3 and a minimum depth of 8,00 for r_3 may be required in order to interface with certain finished devices".

Table B.1 — Male E1 SMALL-BORE CONNECTOR dimensions

Dimensions in millimetres unless otherwise indicated

| Male E1 SMALL-BORE CONNECTOR | | | | |
|------------------------------|---|-----------|---------|---------|
| Reference | Designation | Dimension | | |
| | | Minimum | Nominal | Maximum |
| (a) | Angle of taper (6 % taper nominal) (degrees, reference) | — | (3,44°) | — |
| *c | Projection of the tip of the connector from thread collar | 1,00 | 1,10 | 1,20 |
| $\varnothing d$ | Outside diameter at the tip of the male taper | 5,36 | 5,41 | 5,46 |
| *e ^a | Length of male taper ($\varnothing d$ to $\varnothing g$) | 3,72 | 3,82 | 3,92 |
| $\varnothing f_g$ | Inside diameter at the tip of the male taper. | 0,00 | 2,90 | 2,95 |
| * $\varnothing g$ | Outside diameter of the larger end of the male taper at <i>e</i> from the tip (small end) of the male taper ^{ab} | 5,59 | 5,64 | 5,69 |
| $\varnothing h$ | Major inside thread diameter (diameter at thread root) | 10,13 | 10,23 | 10,33 |
| $\varnothing j$ | Minor inside thread diameter (diameter at thread crest) | 8,55 | 8,65 | 8,75 |
| (L) | Length of engagement (reference) (see Figure B.3) | (3,00) | (4,67) | (6,33) |
| <i>m</i> 3 | Width of the thread groove at the root (symmetrical with <i>n</i> 3) | 1,05 | 1,15 | 1,25 |
| <i>n</i> 3 | Width of the thread groove at the crest (symmetrical with <i>m</i> 3) | 1,80 | 1,90 | 2,00 |
| <i>p</i> | Pitch of double-start, right-hand thread (reference 5 mm lead) | 2,45 | 2,50 | 2,55 |
| *s3 | Length of nozzle from end of collar ^b | 6,82 | — | — |
| <i>t</i> 3 | Angle of projection of nozzle from end of collar (degrees) | 40° | 45° | 50° |
| * \varnothing_{wc} | Diameter of the smallest cylinder that encompasses the outside surfaces of external features of the collar ^d | 13,30 | — | — |
| * \varnothing_{we} | Diameter of the smallest cylinder that encompasses the outside surfaces of external features of the collar ^d | 12,00 | 12,20 | — |
| *x3 | Chord length of thread minor diameter ($\varnothing j$) at thread start | 0,25 | 0,50 | 1,50 |
| *z3 | Face angle at thread start ^f (degrees) | — | — | 40° |

ISO 80369-3:2016/Amd.1:2019(E)

Table B.1 (continued)

| Male E1 SMALL-BORE CONNECTOR | | | | |
|------------------------------|---|-----------|---------|---------|
| Reference | Designation | Dimension | | |
| | | Minimum | Nominal | Maximum |
| $a3g$ | Internal lumen draft angle (starting at $\emptyset f$) | — | — | — |
| $r3g$ | Internal lumen depth (starting at $\emptyset f$) | — | — | — |

a Region of male taper between dimensions e and $s3$ defined by $\emptyset g$ may have draft in the direction of pull no greater than 1,0 degree inclusive (0,5°/side).

b This dimension is required to provide clearance for the inside diameter at the open end of the female taper ($\emptyset D$) and face of female CONNECTOR. Maximum thread profile length is not specified but shall provide clearance for the thread of the male CONNECTOR. The geometry defined by $\emptyset d$ is flush to the face of the collar.

c This dimension is only required where the male CONNECTOR is a source of fluid flow.

d The minimum value of w shall be maintained for the length of 1,00 mm and the maximum value shall be maintained for the length of e . This dimension may be achieved by either the CONNECTOR or the MEDICAL DEVICE which incorporates this CONNECTOR. Alternatively, NON-INTERCONNECTABLE characteristics may be demonstrated using ISO 80369-1:2010, Annex B.

e This dimension is only required where the male CONNECTOR is not a source of fluid flow.

f Other geometries that begin and end at the limits of this specified angle line may be used.

g A minimum diameter of 2,85 for $\emptyset f$, a maximum angle of 2° for $a3$ and a minimum depth of 8,00 for $r3$ may be required in order to interface with certain finished devices.

Figure C.3

Revise Figure C.3 as follows:

Change through bore dimension from $\emptyset 2,8$ to $\emptyset 2,9$ mm.

Change through bore tolerance from $\pm 0,10$ to $+0,05$ mm/ $-0,2$ mm.