



Designation: E 289 – 99

Standard Test Method for Linear Thermal Expansion of Rigid Solids with Interferometry¹

This standard is issued under the fixed designation E 289; the number immediately following the designation indicates the year of original adoption or, in the case of revision, the year of last revision. A number in parentheses indicates the year of last reapproval. A superscript epsilon (ϵ) indicates an editorial change since the last revision or reapproval.

1. Scope

1.1 This test method covers the determination of linear thermal expansion of rigid solids using either a Michelson or Fizeau interferometer.

1.2 For this purpose, a rigid solid is defined as a material which, at test temperature and under the stresses imposed by instrumentation, has a negligible creep, insofar as significantly affecting the precision of thermal length change measurements.

1.3 It is recognized that many rigid solids require detailed preconditioning and specific thermal test schedules for correct evaluation of linear thermal expansion behavior for certain material applications. Since a general method of test cannot cover all specific requirements, details of this nature should be discussed in the particular material specifications.

1.4 This test method is applicable to the approximate temperature range – 150 to 700°C. The temperature range may be extended depending on the instrumentation and calibration materials used.

1.5 The precision of measurement of this absolute method (better than ± 40 nm/m·K) is significantly higher than that of comparative methods such as push rod dilatometry (for example, Test Methods D 696 and E 228) and thermomechanical analysis (for example, Test Method E 831) techniques. It is applicable to materials having low and either positive or negative coefficients of expansion (below 5 $\mu\text{m}/\text{m}\cdot\text{K}$) and where only very limited lengths or thickness of other higher expansion coefficient materials are available.

1.6 Computer or electronic based instrumentation, techniques and data analysis systems equivalent to this test method can be used. Users of the test method are expressly advised that all such instruments or techniques may not be equivalent. It is the responsibility of the user to determine the necessary equivalency prior to use.

1.7 *This standard does not purport to address all of the safety concerns, if any, associated with its use. It is the responsibility of the user of this standard to establish appro-*

priate safety and health practices and determine the applicability of regulatory limitations prior to use.

2. Referenced Documents

2.1 ASTM Standards:

D 696 Test Method for Coefficient of Linear Thermal Expansion of Plastics²

E 220 Test Method for Calibration of Thermocouples by Comparison Techniques³

E 228 Test Method for Linear Thermal Expansion of Solid Materials with a Vitreous Silica Dilatometer⁴

E 473 Terminology Relating to Thermal Analysis⁴

E 831 Test Method for Linear Thermal Expansion of Solid Materials by Thermomechanical Analysis⁴

E 1142 Terminology Relating to Thermophysical Properties⁴

3. Terminology

3.1 Definitions:

3.1.1 The following terms are applicable to this document and are listed in Terminology E 473 and E 1142: coefficient of linear thermal expansion, thermodilatometry, thermomechanical analysis.

3.2 Definitions of Terms Specific to This Standard:

3.2.1 *thermal expansivity*, α_T , at temperature T , is calculated as follows from slope of length ν temperature curve:

$$\alpha_T = \frac{1}{L_i} \lim_{T_2 \rightarrow T_1} \frac{(L_2 - L_1)}{(T_2 - T_1)} = (dL/dT)_{L_i} (T_1 < T_i < T_2) \quad (1)$$

and expressed as $\mu\text{m}/\text{m}\cdot\text{K}$.

NOTE 1—Thermal expansivity is sometimes referred to as instantaneous coefficient of linear expansion.

3.2.2 *mean coefficient of linear thermal expansion*, α_m , the average change in length relative to the length of the specimen accompanying a change in temperature between temperatures T_1 and T_2 , expressed as follows:

$$\alpha_m = \frac{1}{L_0} \frac{(L_2 - L_1)}{(T_2 - T_1)} = (\Delta L/L_0)/\Delta T \quad (2)$$

¹ This test method is under jurisdiction of ASTM Committee E-37 on Thermal Measurements and is the direct responsibility of Subcommittee E37.05 on Thermophysical Properties.

Current edition approved March 10, 1999. Published May 1999. Originally published as E 289 – 65 T. Last previous edition E 289 – 94b.

² Annual Book of ASTM Standards, Vol 08.01.

³ Annual Book of ASTM Standards, Vol 14.03.

⁴ Annual Book of ASTM Standards, Vol 14.02.

where:

α_m is obtained by dividing the linear thermal expansion ($\Delta L/L_0$) by the change of temperature (ΔT). It is normally expressed as $\mu\text{m}/\text{m}\cdot\text{K}$.

3.3 Symbols: Symbols:

3.3.1 α_m = mean coefficient of linear thermal expansion, see 3.2.1, /K.

3.3.2 α_T = expansivity at temperature T , see 3.2.2, /K.

3.3.3 L_0 = original length of specimen at temperature T_0 , mm.

3.3.4 L_1 = length at temperature T_1 , mm.

3.3.5 L_2 = length at temperature T_2 , mm.

3.3.6 ΔL = change in length of specimen between temperatures T_1 and T_2 , mm.

3.3.7 T_0 = temperature at which initial length is L_0 , K.

3.3.8 T_1, T_2 = two temperatures at which measurements are made, K.

3.3.9 ΔT = temperature difference between T_2 and T_1 , K.

3.3.10 N = number of fringes including fractional parts that are measured on changing temperature from T_1 to T_2 .

3.3.11 λ_v = wavelength of light used to produce fringes, nm.

3.3.12 n_r = index of refraction of gas at reference condition of temperature 288K and pressure of 100 kPa.

3.3.13 n = index of refraction of gas at temperature T and pressure, P .

3.3.14 n_1, n_2 = index of refractive of gas at temperature T_1 and T_2 , and pressure, P .

3.3.15 P = average pressure of gas during test, torr.

3.3.16 ΔL_s = change in length of reference specimen between T_1 and T_2 , mm.

4. Summary of Test Method

4.1 A specimen of known geometry can be given polished reflective ends or placed between two flat reflecting surfaces (mirrors). Typical configurations, as shown in Fig. 1, are a cylindrical tube or a rod with hemispherical or flat parallel ends or machined to provide a 3-point support. The mirrors consist

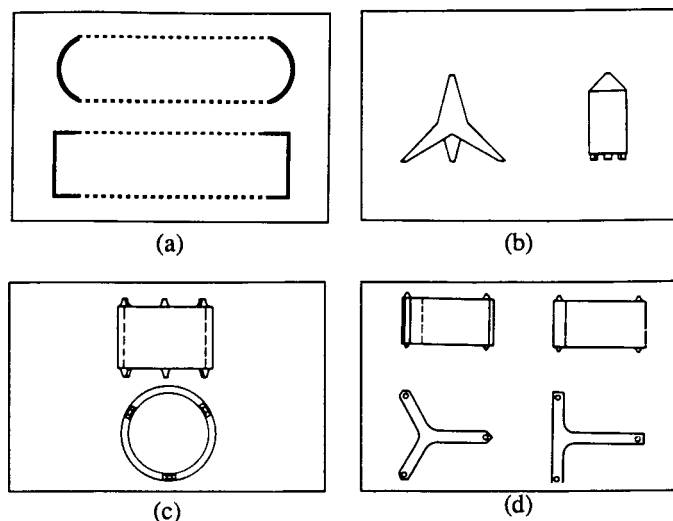

FIG. 1 Typical Specimen Configurations (a) Michelson Type, (b–d) Fizeau Type

of flat-uniform thickness pieces of silica or sapphire with the surfaces partially coated with gold or other high reflectance metal. Light, either parallel laser beam (Michelson, see Fig. 2 and Fig. 3) or from a point monochromatic source (Fizeau, see Fig. 4) illuminates each surface simultaneously to produce a fringe pattern. As the specimen is heated or cooled, expansion or contraction of the specimen causes a change in the fringe pattern due to the optical pathlength difference between the reflecting surfaces. This change is detected and converted into length change from which the expansion and expansion coefficient can be determined.(1-5)

5. Significance and Use

5.1 Coefficients of linear expansion are required for design purposes and are used particularly to determine thermal stresses that can occur when a solid artifact composed of different materials may fail when it is subjected to a temperature excursion(s).

5.2 Many new composites are being produced that have very low thermal expansion coefficients for use in applications where very precise and critical alignment of components is necessary. Push rod dilatometry such as Test Methods D 696, E 228, and TMA methods such as Test Methods E 831 are not sufficiently precise for reliable measurements either on such material and systems, or on very short specimens of materials having higher coefficients.

5.3 The precision of the absolute method allows for its use to:

5.3.1 Measure very small changes in length;

5.3.2 Develop reference materials and transfer standards for calibration of other less precise techniques;

5.3.3 Measure and compare precisely the differences in coefficient of “matched” materials.

5.4 The precise measurement of thermal expansion involves two parameters; change of length and change of temperature. Since precise measurements of the first parameter can be made by this test method, it is essential that great attention is also paid to the second, in order to ensure that calculated expansion coefficients are based on the required temperature difference. Thus in order to ensure the necessary uniformity in temperature of the specimen, it is essential that the uniform temperature zone of the surrounding furnace or environmental chamber shall be made significantly longer than the combined length of specimen and mirrors.

5.5 This test method contains essential details of the design principles, specimen configurations, and procedures to provide precise values of thermal expansion. It is not practical in a method of this type to try to establish specific details of design, construction, and procedures to cover all contingencies that might present difficulties to a person not having the technical knowledge relating to the thermal measurements and general testing practice. Standardization of the method is not intended to restrict in any way further development of improved methodology.

5.6 The test method can be used for research, development, specification acceptance and quality control and assurance.

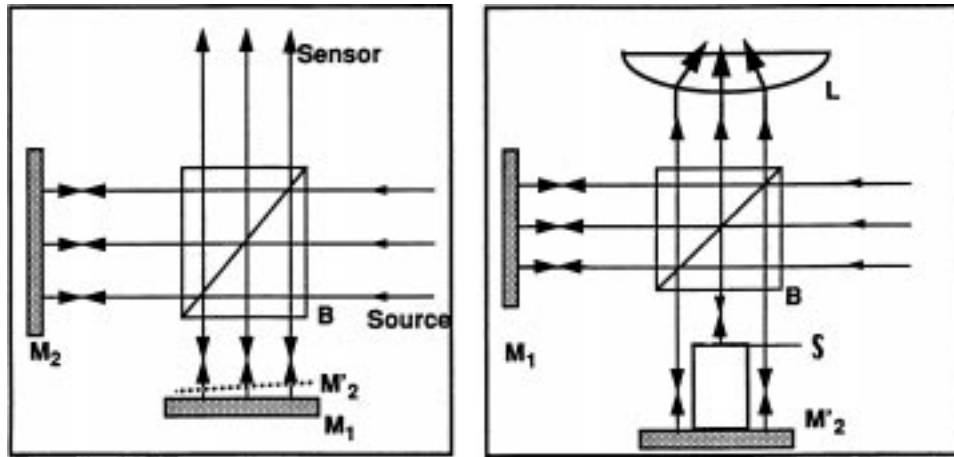

FIG. 2 (a) Principle of the Single Pass Michelson Interferometer, (b) Typical Single Pass System

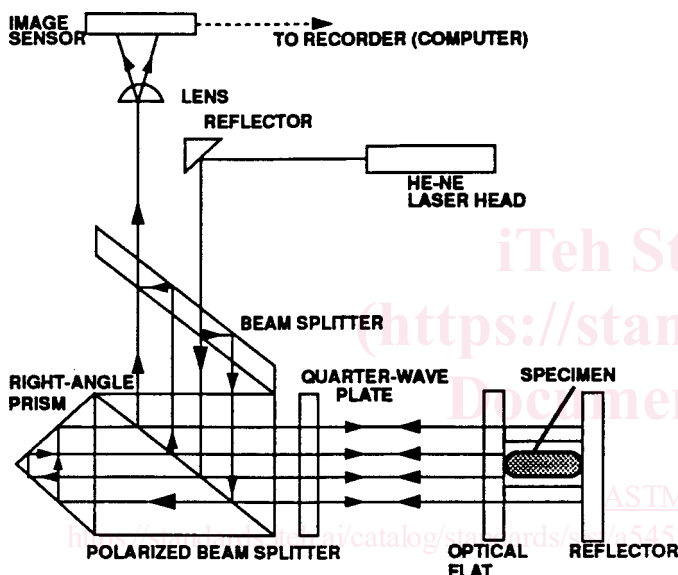

FIG. 3 Typical Double Pass Michelson Interferometer System

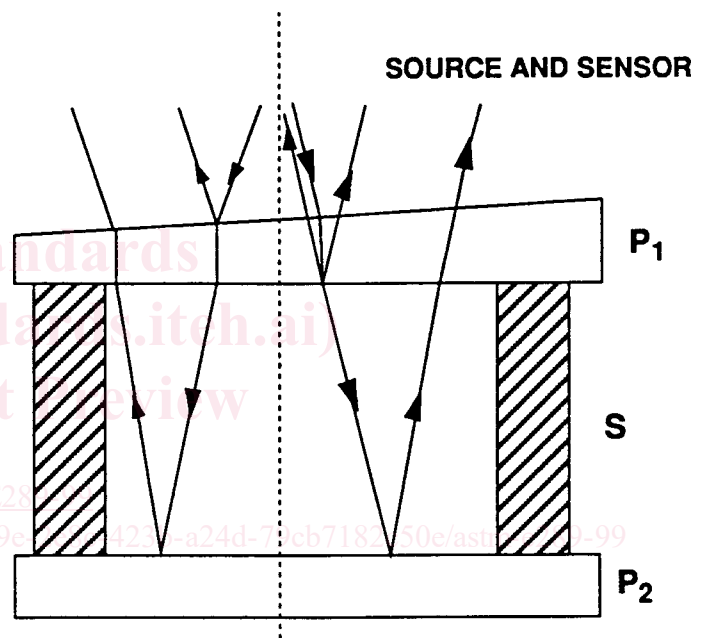

FIG. 4 Principle of the Fizeau Interferometer

6. Interferences

6.1 Measurements should normally be undertaken with the specimen in vacuum or in helium at a low gas pressure in order to off-set optical drifts resulting from instabilities of the refractive index of air or other gases at normal pressures. However, due to the reduced heat transfer coefficient from the surrounding environment, measurement in vacuum or low pressure can make actual specimen temperature measurement more difficult. Additional care and longer equilibrium time to ensure that the specimen is at a uniform temperature are necessary.

6.2 If vitreous silica flats are used, continuous heating to high temperatures may cause them to distort and become cloudy resulting in poor fringe definition.

7. Apparatus

7.1 Interferometer, Michelson Type:

7.1.1 The principle of the single pass absolute system is shown in Fig. 2a. A parallel light beam usually generated from a laser through a beam expander is split by a beam splitter B.

The resulting beams are reflected by mirrors M_1 and M_2 and recombined on B. If M'_2 is inclined slightly over the light-beam its mirror image M'_2 forms a small angle with M_1 producing fringes of equal thickness located on the virtual face M'_2 .

7.1.2 One example of a single contact type is shown in Fig. 2b. A prism or polished very flat faced cylinder specimen form is placed on one mirror with one face also offered to the incident light. An interference pattern is generated and this is divided into two fields corresponding to each end of the specimen. The lens, L, projects the image of the fringes onto a plane where two detectors are placed one on the specimen and the other on the baseplate fields. As the specimen is heated or cooled both the specimen and support change length causing the surface S and M_2 to move relative to M_1 at different rates. The difference in the fringe count provides a measure of the net absolute expansion.

7.1.3 The principle of the double pass system is essentially similar to the single pass with three important distinctions. The specimen can be a relatively simple cylinder with hemispherical or flat ends and requiring less precise machining, the interfering beams are reflected twice from each face to the specimen thus giving twice the sensitivity of the single pass and no reference arm is required. One example of the double pass form is shown in Fig. 3.

7.1.4 It is common practice to use polarized laser light and quarter wave plates to generate circularly polarized light. In this way detectors combined with appropriate analyzers generate signals either with information on fringe number, fraction and motion sense for each beam or linear array data of light intensity which indicate the profile of the instantaneous whole fringe pattern. The array data provides complete information (position of fringe and distance between fringe) to determine the absolute length change of the specimen depending upon the system. These signals are normally processed electronically.

7.2 Fizeau Type:

7.2.1 This type is available in both absolute and comparative versions.

7.2.2 The principle of the absolute method is illustrated in Fig. 4. The specimen is retained between two parallel plates and illuminated by the point source. Expansion or contraction of the specimen causes spatial variation between the plates and radial motion of the circular fringe pattern.

7.2.3 The difference in the fringe counts yields the net absolute expansion of the specimen.

7.2.4 In practice P_1 is wedge shaped (less than 30 min of arc) such that light reflected by the upper face is diverted from the viewing field while the lower face of P_2 is made to absorb the incident light depending upon the total separation of the flats.

7.2.5 For use in the comparative mode two forms are available. These are described in detailed in Annex A1.

7.3 Furnace/Cryostat:

7.3.1 Fig. 5 and Fig. 6 illustrate the construction of a typical vertical type of furnace and cryostat that are suitable for use in undertaking these measurements. For the double pass Michelson system, horizontal forms of furnace and cryostat can be used.

7.4 Temperature Measurement System:

7.4.1 The temperature measurement system shall consist of a calibrated sensor or sensors together with manual, electronic or equivalent read-out such that the indicated temperature can be determined better than $\pm 0.5^\circ\text{C}$.

7.4.1.1 Since this method is used over a broad temperature range, different types of sensors may have to be used to cover the complete range. The common sensor(s) is a fine gage (32 AWG or smaller wire) or thin foil thermocouples calibrated in accordance with Method E 220.

7.4.1.2 Types E and T are recommended for the temperature range -190 to 350°C and Types K and S and Nicrosil for temperature 0 to 800°C . If Type K is used continuously regular checking of the calibration should be undertaken to ensure that contamination or phase change phenomena due to alloy component migration from the junction has not taken place during testing.

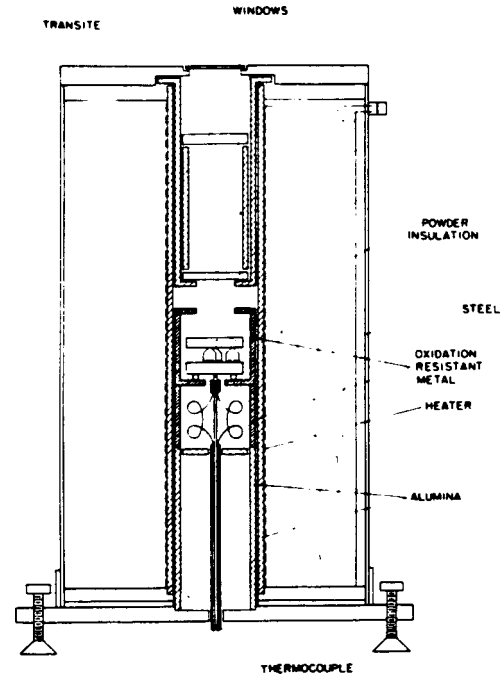

FIG. 5 Typical Furnace

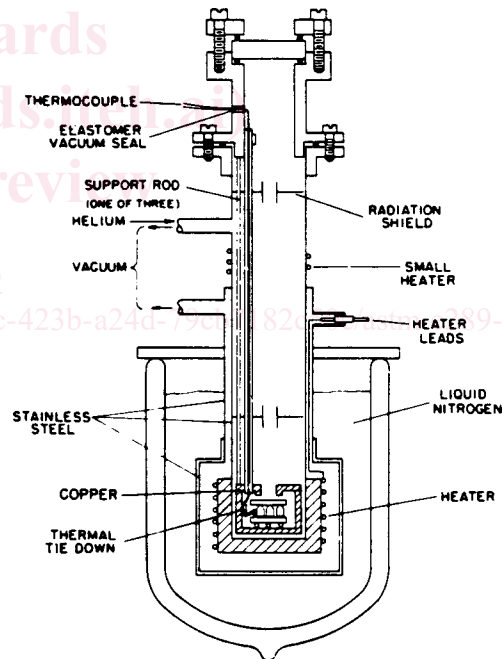

FIG. 6 Typical Low-Temperature Cryostat

7.4.1.3 In all cases where thermocouples are used they shall be referenced to 0°C by means of an ice water bath or equivalent electronic reference system insulated from the effects of temperature variations in the immediate surrounding ambient.

7.4.1.4 For temperatures below -190°C a calibrated carbon or germanium resistance thermometer is used.

7.5 A measurement instrument such as an index micrometer or calipers capable of reading to 0.01 mm in order to determine the initial and final lengths of the test specimen (and other