

---

---

**Conveyor belts — Transverse flexibility  
(troughability) — Test method**

*Courroies transporteuses — Flexibilité transversale (aptitude à la  
mise en auge) — Méthode d'essai*

**iTeh STANDARD PREVIEW**  
**(standards.iteh.ai)**

[ISO 703:2017](https://standards.iteh.ai/catalog/standards/sist/85f00396-8685-4d3b-92f1-e9d14b0953c6/iso-703-2017)

[https://standards.iteh.ai/catalog/standards/sist/85f00396-8685-4d3b-92f1-  
e9d14b0953c6/iso-703-2017](https://standards.iteh.ai/catalog/standards/sist/85f00396-8685-4d3b-92f1-e9d14b0953c6/iso-703-2017)



**iTeh STANDARD PREVIEW**  
**(standards.iteh.ai)**

ISO 703:2017

<https://standards.iteh.ai/catalog/standards/sist/85f00396-8685-4d3b-92f1-e9d14b0953c6/iso-703-2017>



**COPYRIGHT PROTECTED DOCUMENT**

© ISO 2017, Published in Switzerland

All rights reserved. Unless otherwise specified, no part of this publication may be reproduced or utilized otherwise in any form or by any means, electronic or mechanical, including photocopying, or posting on the internet or an intranet, without prior written permission. Permission can be requested from either ISO at the address below or ISO's member body in the country of the requester.

ISO copyright office  
Ch. de Blandonnet 8 • CP 401  
CH-1214 Vernier, Geneva, Switzerland  
Tel. +41 22 749 01 11  
Fax +41 22 749 09 47  
copyright@iso.org  
www.iso.org

# Contents

Page

Foreword.....	iv
Introduction.....	v
1 Scope.....	1
2 Normative references.....	1
3 Terms and definitions.....	1
4 Symbols.....	1
5 Principle.....	1
6 Apparatus (see <a href="#">Figure 1</a> ).....	2
7 Test piece.....	3
7.1 Dimensions.....	3
7.2 Conditioning.....	3
8 Procedure.....	3
9 Calculation and expression of results.....	4
10 Test report.....	4
Bibliography.....	5

## iTeh STANDARD PREVIEW (standards.iteh.ai)

[ISO 703:2017](#)

<https://standards.iteh.ai/catalog/standards/sist/85f00396-8685-4d3b-92fl-e9d14b0953c6/iso-703-2017>

## Foreword

ISO (the International Organization for Standardization) is a worldwide federation of national standards bodies (ISO member bodies). The work of preparing International Standards is normally carried out through ISO technical committees. Each member body interested in a subject for which a technical committee has been established has the right to be represented on that committee. International organizations, governmental and non-governmental, in liaison with ISO, also take part in the work. ISO collaborates closely with the International Electrotechnical Commission (IEC) on all matters of electrotechnical standardization.

The procedures used to develop this document and those intended for its further maintenance are described in the ISO/IEC Directives, Part 1. In particular the different approval criteria needed for the different types of ISO documents should be noted. This document was drafted in accordance with the editorial rules of the ISO/IEC Directives, Part 2 (see [www.iso.org/directives](http://www.iso.org/directives)).

Attention is drawn to the possibility that some of the elements of this document may be the subject of patent rights. ISO shall not be held responsible for identifying any or all such patent rights. Details of any patent rights identified during the development of the document will be in the Introduction and/or on the ISO list of patent declarations received (see [www.iso.org/patents](http://www.iso.org/patents)).

Any trade name used in this document is information given for the convenience of users and does not constitute an endorsement.

For an explanation on the meaning of ISO specific terms and expressions related to conformity assessment, as well as information about ISO's adherence to the World Trade Organization (WTO) principles in the Technical Barriers to Trade (TBT) see the following URL: [www.iso.org/iso/foreword.html](http://www.iso.org/iso/foreword.html).

The committee responsible for this document is ISO/TC 41 *Pulleys and belts (including veebelts)*, Subcommittee SC 3, *Conveyor belts*.

This fourth edition of ISO 703 cancels and replaces ISO 703:2007, of which it constitutes a minor revision.

## Introduction

A large number of conveyor belts work in the shape of a trough. If a conveyor belt is too stiff transversely it does not rest on the central idler roller when unloaded. Its balance is then unstable and it is subject to lateral travel, which may cause its destruction.

It is possible to make a section of the conveyor belt take on the shape of a trough under its own mass, by suspending the section by its edges. However, this does not necessarily indicate what happens when the conveyor belt is not carrying a load.

The results obtained from the test method specified in this document will, however, allow an assessment to be made as to whether the troughing characteristics of the conveyor belt are suitable for the intended application.

## iTeh STANDARD PREVIEW (standards.iteh.ai)

[ISO 703:2017](#)

<https://standards.iteh.ai/catalog/standards/sist/85f00396-8685-4d3b-92fl-e9d14b0953c6/iso-703-2017>

**iTeh STANDARD PREVIEW**  
**(standards.iteh.ai)**

ISO 703:2017

<https://standards.iteh.ai/catalog/standards/sist/85f00396-8685-4d3b-92ff-e9d14b0953c6/iso-703-2017>

# Conveyor belts — Transverse flexibility (troughability) — Test method

## 1 Scope

This document specifies a test method for determining the transverse flexibility (troughability) of a conveyor belt, expressed as a ratio,  $F/L$ . The method is not suitable or valid for light conveyor belts as described in ISO 21183-1.

NOTE The transverse “flexibility” determined by the method described in this document is only indirectly associated with the inverse of flexural modulus as specified in ISO 178. Nor does it take into consideration the differences in “flexibility” as exhibited by three-point and four-point bending, which takes account of the flexural strain and the thickness of the test piece.

## 2 Normative references

The following documents are referred to in the text in such a way that some or all of their content constitutes requirements of this document. For dated references, only the edition cited applies. For undated references, the latest edition of the referenced document (including any amendments) applies.

ISO 583, *Conveyor belts with a textile carcass — Total belt thickness and thickness of constitutive elements — Test methods*

ISO 7590, *Steel cord conveyor belts — Methods for the determination of total thickness and cover thickness*

ISO 18573, *Conveyor belts — Test atmospheres and conditioning periods*

## 3 Terms and definitions

No terms and definitions are listed in this document.

ISO and IEC maintain terminological databases for use in standardization at the following addresses:

- IEC Electropedia: available at <http://www.electropedia.org/>
- ISO Online browsing platform: available at <http://www.iso.org/obp>

## 4 Symbols

- $F$  vertical deflection in test piece corrected for belt thickness, in millimetres
- $F_1$  vertical deflection in test piece, in millimetres (see [Figures 1](#) and [2](#))
- $L$  length of test piece when laid flat, in millimetres (equivalent to full width of installed conveyor belt)
- $d$  thickness of the test piece, in millimetres (see [Figure 2](#)).

## 5 Principle

A test piece, consisting of a transverse section of belt of length,  $L$ , is suspended at both ends with the carrying face uppermost, so that the upper edges of these ends are in the same horizontal plane.

The transverse flexibility (troughability) is determined by measuring the maximum deflection,  $F$ , of the test piece under its own weight. It is expressed as the ratio  $F/L$ .

**6 Apparatus (see Figure 1)**

**6.1 Two rigid horizontal bars**, conveniently supported. The unsupported length of the bars shall be greater than the test length,  $L$ .

**6.2 Two clamps**, to be attached to the ends of the test piece, with suspension lugs for attachment to the suspending wires. The construction of the clamps shall allow for a rigid bar or straightedge to be placed in contact with the belt, as shown in Figure 2, to establish the datum line necessary for measuring the deflection. The clamps shall be sufficiently wide and rigid to maintain the width of the test pieces free from curvature, and shall exert no bending moment which might influence the deflection of the test piece.

**6.3 Four steel suspension wires**, of equal length, each with adjustable stirrups on both ends for attachment to the horizontal bars and clamps. The attachments to the horizontal bars and clamps should not impede the free movement of the adjustable stirrups when maintaining the suspension wires in the vertical during the test.

**6.4 Means of measuring the deflection,  $F_1$** , to the nearest millimetre (see Figure 2).

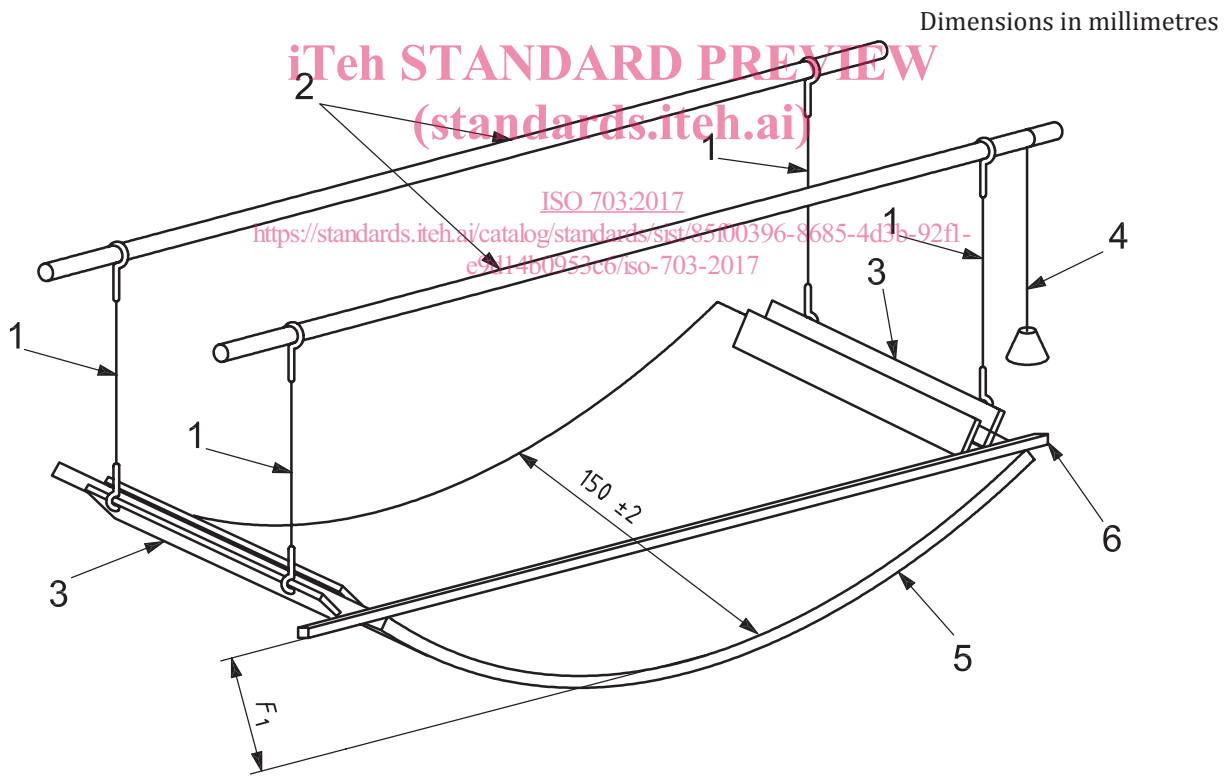

- Key**
- 1 four steel suspension wires
  - 2 two rigid horizontal bars
  - 3 two clamps
  - 4 plumb line
  - 5 test piece
  - 6 rigid bar to establish datum line

**Figure 1 — Typical apparatus for measuring transverse flexibility (troughability)**



## 7 Test piece

### 7.1 Dimensions

The test piece shall conform to the following requirements:

- its form shall be a rectangular parallelepiped;
- its length,  $L$ , shall be the overall width of the installed conveyor belt, when laid flat;
- its width, in the longitudinal direction of the belt, shall be  $(150 \pm 2)$  mm;
- its thickness,  $d$ , shall be the overall thickness of the conveyor belt.

### 7.2 Conditioning

Condition the test pieces in accordance with ISO 18573, using atmosphere A, B or C, and then carry out the tests immediately after completion of the conditioning period.

## 8 Procedure

Immediately before the test, ensure that the clamps are free to swivel and do not exert a bending force on the test piece.

Measure the flat length,  $L$ , of the test piece in millimetres.

Measure the thickness,  $d$ , of the test piece, in millimetres, in accordance with ISO 583 or ISO 7590.

Fit the test piece, carrying face uppermost, while in the flat position, into the suspended clamps.

Allow the test piece to fall under its own weight from the flat position into the troughed position.

Adjust the apparatus so that the suspending forces act vertically throughout the test period.

After 5 min, measure the vertical deflection,  $F_1$ , of the test piece (see [Figure 2](#)) and add to this measurement the dimension  $0,5d$  to give the value for  $F$ .

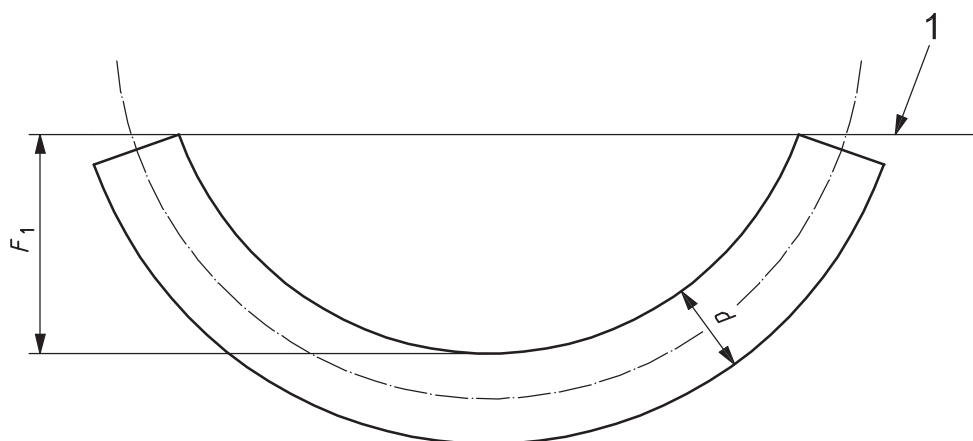

#### Key

- $d$  thickness of test piece
- $F_1$  vertical deflection
- 1 datum line

**Figure 2 — Determination of deflection,  $F_1$**