



Designation: ~~C301-98 (Reapproved 2003)~~ Designation: C 301 – 04 (Reapproved 2009)

## Standard Test Methods for Vitrified Clay Pipe<sup>1</sup>

This standard is issued under the fixed designation C 301; the number immediately following the designation indicates the year of original adoption or, in the case of revision, the year of last revision. A number in parentheses indicates the year of last reapproval. A superscript epsilon ( $\epsilon$ ) indicates an editorial change since the last revision or reapproval.

*This standard has been approved for use by agencies of the Department of Defense.*

### 1. Scope

1.1 These test methods cover the equipment for, and the techniques of, testing vitrified clay pipe prior to installation. Tests using whole pipe determine the resistance to crushing and hydrostatic forces. Tests using pipe fragments measure the amount of water absorption of the pipe body and the quantity of acid-soluble material that may be extracted from it.

~~1.2 The values stated in inch-pound units are to be regarded as the standard. The values stated in parentheses are for information only.~~

~~1.3 This standard does not purport to address the safety concerns, if any, associated with its use. It is the responsibility of the user of this standard to establish appropriate safety and health practices and determine the applicability of regulatory limitations prior to use.~~

NOTE 1—The following standards also apply to clay pipe and can be referenced for further information: Practice C 12 and Test Method C 828; Specifications C 425 and C 700.

1.2 The values stated in inch-pound units are to be regarded as standard. The values given in parentheses are mathematical conversions to SI units that are provided for information only and are not considered standard.

1.3 This standard does not purport to address the safety concerns, if any, associated with its use. It is the responsibility of the user of this standard to establish appropriate safety and health practices and determine the applicability of regulatory limitations prior to use.

### 2. Referenced Documents

2.1 *ASTM Standards:*<sup>2</sup>

C 12 Practice for Installing Vitrified Clay Pipe Lines

C 425 Specification for Compression Joints for Vitrified Clay Pipe and Fittings

C 700 Specification for Vitrified Clay Pipe, Extra Strength, Standard Strength, and Perforated

C 828 Test Method for Low-Pressure Air Test of Vitrified Clay Pipe Lines

C 896 Terminology Relating to Clay Products

E 6 Terminology Relating to Methods of Mechanical Testing

### 3. Terminology

3.1 *Definitions:*

3.1.1 For definitions of terms used in these test methods, refer to Terminology E 6 and Terminology C 896.

### 4. Significance and Use

4.1 *Meaning and Suitability*—The tests called for herein, from their results, indicate the suitability and acceptability of vitrified clay pipe for specifications acceptance, design purposes, regulatory statutes, manufacturing control, and re-search.

### 5. Bearing Strength

5.1 *Test Specimens:*

5.1.1 The test specimens shall be sound, full-size pipe and shall be selected by the purchaser, or his representative, at points he designates when placing the order.

<sup>1</sup> These test methods are under the jurisdiction of ASTM Committee C-4/C04 on Vitrified Clay Pipe and is the direct responsibility of Subcommittee C04.20 on Methods of Test and Specifications.

Current edition approved November 1, 2003; 2009. Published February 2004; October 2009. Originally approved in 1952. Last previous edition approved in 1998 as C301-98; C 301 – 04.

<sup>2</sup> For referenced ASTM standards, visit the ASTM website, www.astm.org, or contact ASTM Customer Service at service@astm.org. For *Annual Book of ASTM Standards* volume information, refer to the standard's Document Summary page on the ASTM website.

5.1.2 The number of specimens to be tested shall not exceed 0.5 % of the number of pipe of each size furnished, except that no less than two specimens shall be tested.

5.2 Measurement and Inspection of Specimens:

5.2.1 The specimens shall be free of all visible moisture and frost. These specimens shall be inspected and measured for conformance with the applicable specifications. The results of these observations shall be recorded.

5.2.2 Specimens that are observed to have defects in excess of the limits permitted in the applicable specifications shall be discarded and replaced with additional specimens from the lot to be tested.

5.3 Loading Apparatus (see Fig. 1):

5.3.1 Testing Machine:

5.3.1.1 The loading apparatus shall consist of a testing machine capable of applying loads, with upper and lower bearings capable of transmitting these loads to the pipe. The bearings shall be bearing beams and contact edges.

5.3.1.2 Any motor driven testing machine that is capable of applying a load at a uniform rate of  $2000 \pm 500$  lbf/min·linear ft ( $29.4(29.2 \pm 7.47.3)$  kN/min·linear m) of pipe length, shall be used for making the test.

5.3.1.3 The load may be applied at a rapid rate until 50 % of the required bearing strength is reached. Subsequently, the load shall be applied to the pipe at a uniform rate of  $2000 \pm 500$  lbf/min·linear ft ( $29.4(29.2 \pm 7.47.3)$  kN/min·linear m) of pipe length without vibration or shock.

5.3.1.4 The testing machine shall be sufficiently rigid so that the load distribution will not be appreciably affected by the deformation or yielding of any part. The machine and bearings shall be constructed to transmit the load in a vertical plane through the longitudinal axes of the bearings and pipe. The bearings shall be attached to the machine so as to receive and uniformly transmit

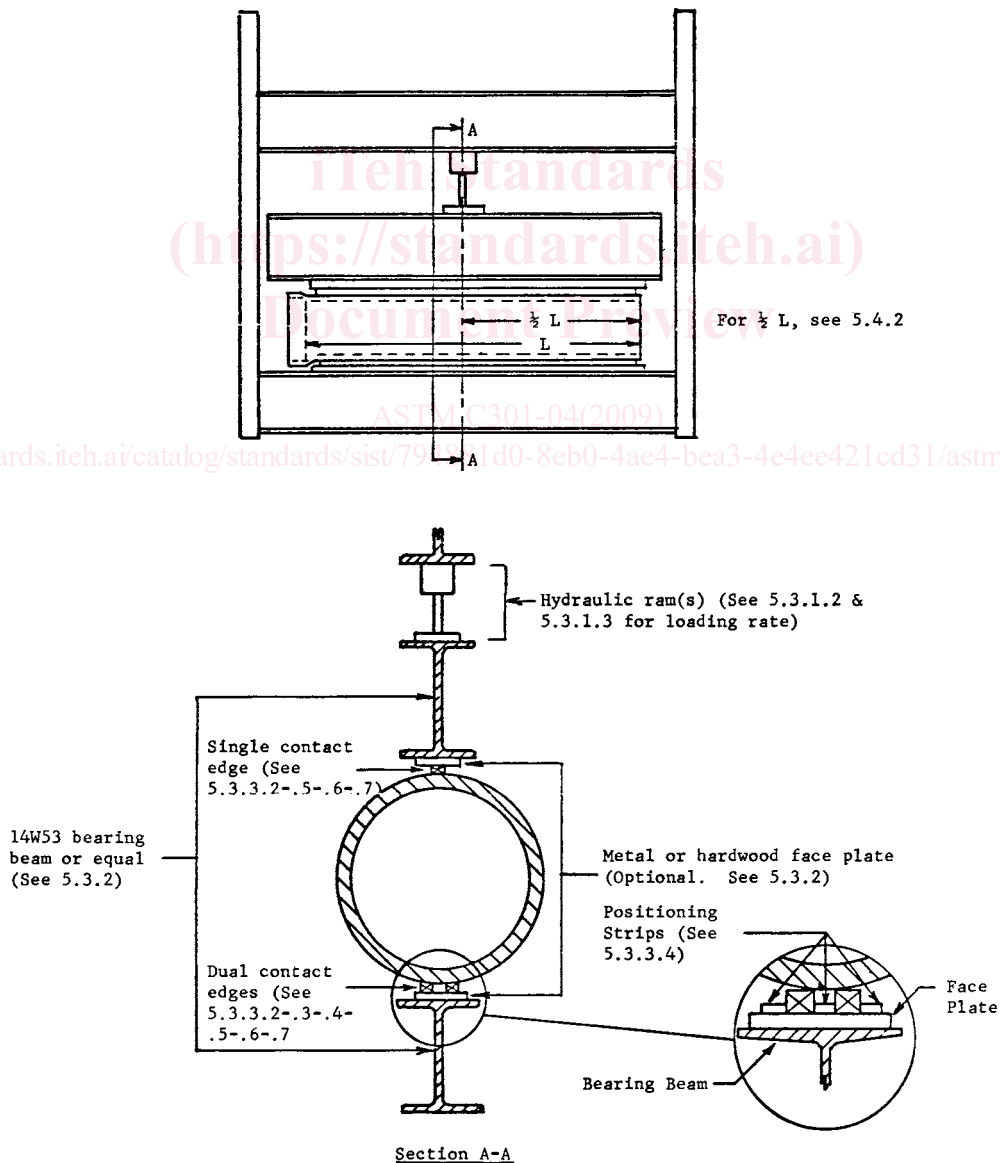

FIG. 1 Three-Edge Bearing Testing (see 5.3.4 for Segmented Testing)