



Designation: E 296 – 70 (Reapproved 1999)

Standard Practice for Ionization Gage Application to Space Simulators¹

This standard is issued under the fixed designation E 296; the number immediately following the designation indicates the year of original adoption or, in the case of revision, the year of last revision. A number in parentheses indicates the year of last approval. A superscript epsilon (ϵ) indicates an editorial change since the last revision or reapproval.

1. Scope

1.1 The purpose of this practice is to provide application criteria, definitions, and supplemental information to assist the user in obtaining meaningful vacuum ionization gage measurements below 10^{-1} N/m² (10^{-3} torr) in space-simulation facilities. Since a variety of influences can alter observed vacuum measurements, means of identifying and assessing potential problem areas receive considerable attention. This practice must be considered informational, for it is impossible to specify a means of applying the vacuum-measuring equipment to guarantee accuracy of the observed vacuum measurement. Therefore, the user's judgment is essential so that if a problem area is identified, suitable steps can be taken to either minimize the effect, correct the observed readings as appropriate, or note the possible error in the observation.

1.2 While much of the discussion is concerned with the application of hot-cathode ionization gages, no exclusion is made of cold-cathode designs. Since a great deal more experience with hot-cathode gages is available and hot-cathode devices are used in the majority of applications, the present emphasis is fully warranted.

1.3 The values stated in inch-pound units are to be regarded as the standard. The metric equivalents of inch-pound units may be approximate.

2. Referenced Documents

2.1 ASTM Standards:

E 297 Methods for Calibrating Ionization Vacuum Gage Tubes²

3. Terminology

3.1 *Definitions*—The following definitions are necessary to understanding meaningful application of ionization-type vacuum-measurement devices and are useful in differentiating between pressure, density, and flux measuring devices for proper application and interpretation of low-density molecular measurements.

3.1.1 *Blears effect*—the reduction of the partial pressure of organic vapors within the envelope of a tubulated ionization gage below the partial pressure that would prevail in the envelope with a tubulation having infinite conductance.

3.1.2 *controlled-temperature enclosed gage*—an enclosed gage in which the envelope is maintained at nearly uniform constant temperature by suitable means.

3.1.3 *enclosed ionization gage*—an ionization gage for which the ion source region is enclosed over at least $0.95 \times 4\pi$ steradians about the center of the region by an envelope at a known temperature with only a single opening such that all molecules entering the ion source region must have crossed a plane located outside this region.

3.1.4 *equivalent nitrogen concentration*—the quantity obtained when the ion-collector current of a nude gage (in amperes) for the gas in the system is divided by the concentration sensitivity of the gage for nitrogen. This sensitivity is defined as the ratio of gage ion collector current in amperes to molecular concentration in molecules per cubic metre of nitrogen under specified operating conditions.

3.1.5 *equivalent nitrogen flux density*—the quotient of the current output of an enclosed vacuum gage operating under specified conditions divided by the molecular flux sensitivity for nitrogen.

3.1.6 *equivalent nitrogen pressure*:

3.1.6.1 For a nude gage *equivalent nitrogen pressure* is obtained by multiplying the *equivalent nitrogen concentration* by kT where k is the Boltzmann constant and T is the mean absolute temperature of the walls from which the gas molecules travel to the ionizing region of the gage, averaged as nearly as possible on the basis of relative molecular flux.

3.1.6.2 *standard equivalent nitrogen pressure*—for a nude gage the value of the equivalent nitrogen pressure is obtained when $T = 296\text{K}$ (or standard ambient temperature) is used in the factor kT .

3.1.6.3 For a tubulated gage, the *equivalent nitrogen pressure* in newton per square metre is obtained by dividing the ion collector current in amperes for a given gas by the pressure sensitivity of the gage in amperes per newton per square metre for pure nitrogen under specified operating conditions.

3.1.7 *gage background*—the part of the indicated ion collector current produced by phenomena other than ions formed in the gas phase arriving at the collector.

¹ These practices are under the jurisdiction of ASTM Committee E-21 on Space Simulation and Applications of Space Technology and are the direct responsibility of Subcommittee E21.04 on Space Simulation Test Methods.

Current edition effective Feb. 27, 1970. Originally issued 1966. Replaces E 296 – 66 T.

² Discontinued, see 1984 Annual Book of ASTM Standards, Vol 15.03.

3.1.8 *gage limit*—a pressure or concentration indication four times the background.

3.1.9 *ionization gage*—a vacuum gage comprising a means of ionizing the gas molecules and a means of correlating the number and type of ions produced with the pressure or concentration of the gas. Various types of ionization gages are distinguished according to the method of producing the ionization.

3.1.9.1 *cold-cathode ionization gage*—an ionization gage in which the ions are produced by a cold-cathode gas discharge, usually in the presence of a magnetic field.

3.1.9.2 *hot-cathode ionization gage*—an ionization gage in which ion production is initiated and sustained by electrons emitted from a hot cathode.

3.1.10 *molecular flux density*—the number of molecules incident on a real or imaginary surface per unit area per unit time. The unit is molecules per second per square centimetre.

3.1.11 *molecular flux sensitivity*—the output current of an enclosed vacuum gage per unit molecular flux density under specified gage operating conditions and random particle motion.

3.1.12 *nude ionization gage*—an ionization gage for which the center of the ion source region is exposed to direct molecular flux (from surfaces not forming part of the gage) in all directions except for a solid angle less than $0.05 \times 4 \pi$ steradians (determined by the parts of the gage head). No structures shall be within one sensing element diameter of any part of the sensing element unless similar structures are present during calibration.

NOTE 1—The solid angle subtended by a circular disk of radius r with axis passing through the center point of the solid angle at a distance y from the disk is given as follows:

$$\omega = 2 \pi [1 - y/(y^2 + r^2)^{1/2}] \quad (1)$$

For $\omega = 0.05 \times 4 \pi$, the distance y must equal $2.07 r$, a value which should be easily attainable for typical ionization gage electrodes mounted on a circular base of radius r .

3.1.13 *orifice ionization gage*—an enclosed gage containing a single orifice or port having a length less than 0.15 of its diameter such that molecules from the chamber can enter the envelope directly from within a solid angle nearly equal to 2π steradians.

3.1.14 *partial pressure gage*—an ionization gage that indicates the partial pressure of any gas in a mixture irrespective of the partial pressure of other gases in the mixture.

3.1.15 *partially enclosed ionization gage*—a gage in which the ion formation region is enclosed over less than $0.95 \times 4 \pi$ steradians but more than $0.05 \times 4 \pi$ steradians about center by an envelope which has one or more openings such that not all molecules entering the ion formation region must first cross a plane located outside this region.

3.1.16 *recovery time*—the time required for the pressure indication of a gage to reach and remain within pressure indications not more than 105 % or less than 95 % of the final average steady-state value after a sudden change in the operating conditions of the gage without appreciable change in the gas pressure in the vacuum chamber. Pressure changes less than 5 % of the initial value shall be regarded as within the normal fluctuations of pressure indication.

3.1.17 *response time*—the time required for the change in pressure indication as a result of a specified gas (or vapor) within a gage tube to reach $(1 - 1/e)$ (or 63 %) of the change in steady-state pressure after a relatively instantaneous change of the pressure of that gas in the vacuum chamber. The response time may depend on the time of adsorption of the gas (or vapor) on the walls of the gage tube as well as the geometry of the tube (including the connecting line to the vacuum chamber).

3.1.18 *tubulated ionization gage*—an enclosed ionization gage for which the opening in the envelope is determined by a tubulation of diameter equal to or less than the minimum diameter of the part of the envelope adjacent to the ion source region and of length at least equal to the diameter of the tubulation.

3.1.19 *vacuum gas analyzer*—a device capable of indicating the relative composition of a gas mixture at low pressures.

4. Apparatus

4.1 *Equipment*—Acceptable vacuum-measuring equipment shall consist of those items in which performance is compatible with obtaining meaningful measurements. The basic elements consist of a power supply, readout, and sensing element. These items must be acceptable for applying the proper calibrations described in Methods E 297. The electronic power supply and readout shall have been calibrated either separately or in conjunction with the test stand calibration of the gage sensor. Special attention must be given to cabling, especially where cabling runs are long (as in large vacuum systems) in order that impedance or resistance errors are properly accounted for in the calibration activities.

4.2 *Calibration*—These practices are not concerned with gage calibration criteria except as applicable during test. Test stand calibration criteria is provided by Methods E 297. Recycle of the vacuum-measuring equipment to the calibration test stand should not be programmed only on a calendar basis. Periodic recycle can best be determined by the individual operators compatible with usage requirements. Upon any strong indication that usage in test may have produced an alteration in gage factor, suspect elements shall be returned to the test stand. Alternatively, calibration before and after test may be incorporated as part of major test programs.

5. Gage Mounting

5.1 *Flanges and Couplings*—Flanging and connections are specified in this section both for dimensions and material between ionization gages and the external walls of high-vacuum systems to produce a geometrically standard mounting method (compatible with the calibration test stand) which is a clean assembly free of interfering contamination such as that produced by organic or high vapor-pressure sealing materials.

5.1.1 *Tubulated Ionization Gage* (Fig. 1):

5.1.1.1 The flange material shall be stainless steel with a glass-to-metal seal connecting the gage to the flange stub. The flanges shall be welded or high-temperature brazed with appropriate cleaning to remove residual flux. Gasket material shall be metallic: copper, aluminum, indium, and so forth.

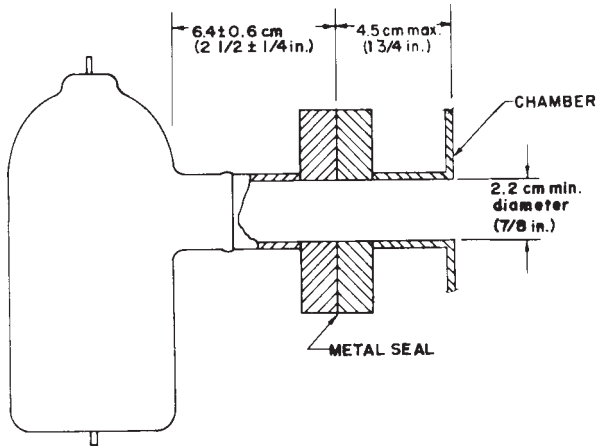

FIG. 1 Tubulated Ionization Gage

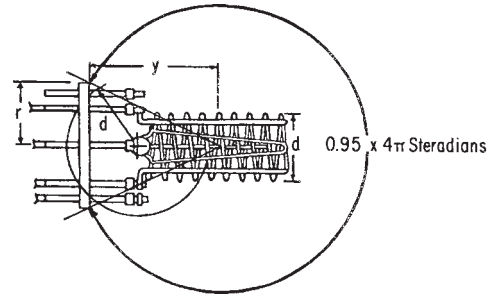

FIG. 3 Nude Ion Gage (Probe) Mounted Clear of Walls and Structures

5.1.1.2 The gage may be attached directly to chamber eliminating flanges and gasketing providing limiting dimensions are adhered to.

5.1.2 *Nude or Partially Enclosed Ionization Gages* (Fig. 2 and Fig. 3)—See 5.1.1.1.

5.1.2.1 Intent is to give maximum solid-angle (line-of-sight) exposure of the gage elements to the chamber environments.

5.2 *Internally Mounted Ionization Gages*—Limitations for mounting ionization gages internally are specified in this section to provide mounting considerations applicable to placing any vacuum-ionization gage within the vacuum volume. Measurement considerations are provided in Section 6.

5.2.1 *Tubulated Ionization Gages:*

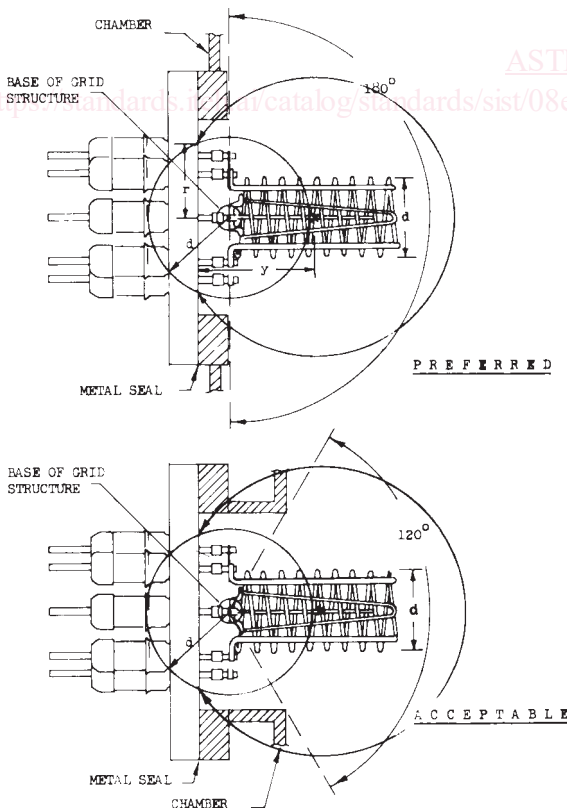

FIG. 2 Flange-Mounted Nude Ionization Gage

5.2.1.1 *Mechanical*—The mechanical support and positioning of internally mounted tubulated gages must not influence the distribution of molecules across the tubulation.

5.2.1.2 *Thermal*—Since internally mounted tubulated gages will experience significantly different heat transfer conditions from the envelope, care should be taken to provide means in the mounting to monitor or control, or both, the equilibrium temperature condition of the envelope that can be duplicated in a calibration test stand. Temperature control can be by either active or passive means—an active means representing a *controlled temperature enclosed gage*.

5.2.1.3 *Electrical*—Shielding of the electrical leads, especially the collector, poses somewhat more of a problem than with externally mounted gages. Care must be taken in the use of unshielded wires that external pickup does not compromise the collector current. In any hookup, aside from leakage and especially where long cables may be used, capacitance and resistance losses may contribute significant errors unless corrected or suitably accounted for during calibration.

5.2.2 *Nude and Partially Enclosed Gages:*

5.2.2.1 *Mechanical*—The mechanical support shall be such as to provide equivalent acceptance angles of molecular flux as defined for the flange-mounted condition (Fig. 2 and Fig. 3).

5.2.2.2 *Thermal*—Thermal considerations with nude and partially enclosed gages are less significant than with tubulated gages. Generally, the mechanical support will require no special attention except in extreme conditions where conduction or radiation paths to nearby surfaces provide an extreme temperature differential.

5.2.2.3 *Electrical*—Same as 5.2.1.3.

6. *Gage Orientation*

6.1 *General*—Orientation of gages is significant where the gas atmosphere in a vacuum chamber has directional properties. These properties are of at least three kinds: (1) directional molecular flux density (directional pressure) as in gas exchange between a source and a pump, where the quantity flowing toward the pump is greater than that flowing from the pump; (2) directional composition, as in gas exchange between an outgassing body and a cryopump, where the outgassing material is mainly condensible and the material flowing from the cryopump is mainly noncondensable; (3) directional temperature, as in gas exchange between a warm and cold surface. The magnitude of the first two effects is dependent on the fraction of incident molecules captured by the pump; flux densities in opposite directions may differ by a decade or more. The

magnitude of the third effect is of the order of the temperature difference. Significant directional gas flow can occur in the normal operation of large simulators using solar simulation sources, cryopumping, moderate to heavy gas loads arising from test items, and temperature extremes throughout the internal surfaces.

6.2 Response of Gage in Directional Environments—Nude gages indicate primarily the local gas concentration, but they are sensitive to the direction of the incident gas because of their nonsymmetrical construction. The response of enclosed gages is dependent on the flux density and the direction of gas incidence. The directional effect is, to a first approximation, proportional to the cosine of the angle between the direction of gas flow and the normal to the plane of the gage mount, but also depends on the geometry of the tubulation.

6.3 Ideal Gage Orientation:

6.3.1 Ideal simulation of space vacuum would be achieved if outgassing products from the test item were pumped with a 100 % capture coefficient, while the test item was bombarded with a stream of ions, molecules, and other particles having the flux density, composition, and energy present in space. Gages placed to measure these characteristics of the gas environment incident on the test item in a practical simulator would indicate the degree of departure from space conditions.

6.3.2 The flux density of particles incident on the test item may be measured near the surface of the test item or near the source (the wall) with an appropriately placed, enclosed gage facing the wall. The latter arrangement is mechanically simpler, but the interpretation of readings is more complex if the gas load leaving the wall is not uniform.

6.4 Departures from Ideal Orientation—In cases in which the incident gas flux is known to be a decade or more below the level at which significant effects occur, the directional properties of the environment may be safely ignored. Likewise, phenomena such as electrical breakdown may be known to depend on gas concentration rather than flux, and directional gages are not appropriate.

6.5 Reporting of Data—The gage readings should be reported in terms that clearly indicate the location, orientation, and type of enclosure of the gage when substantial directional effects are present.

7. Operational Errors

7.1 Ion Coupling—Errors may be introduced into the observed readings through ion coupling. Such coupling may result in either loss or gain of the observed current reading. The simplest check that can be made is the isolation of the gage by intermittent operation of possible sources of ion coupling.

7.1.1 Sources:

7.1.1.1 Other vacuum ionization measurement devices such as multiple ionization gages or vacuum gas analyzers (VGA) being run in close proximity,

7.1.1.2 Radioactive sources emitting nuclear radiations,

7.1.1.3 Other sources of electromagnetic radiation or particle radiation being used to simulate the solar spectrum or the particulate radiation of space and,

7.1.1.4 Other hot-filament or high-voltage test elements capable of producing ions.

7.1.2 Magnetic Field Effects:

7.1.2.1 Operational characteristics of hot- or cold-cathode ionization gages may be influenced by the presence of disturbing magnetic or electrical fields. Published data on experiments relating the alteration of a particular gage operation versus field strengths and the gage-field orientation are limited.

7.1.2.2 To minimize introducing such errors, gages should not be placed in close proximity to known sources of strong magnetic or electrical fields. In the event it is necessary to operate a gage in the presence of such fields, intermittent operation of the field source should be made to note possible influence. Under extreme cases, special shielding may be used to reduce external field effects. Under such cases, a check must be made to ascertain that the shielding itself does not alter the gage sensitivity.

7.2 Temperature Effects—Operational temperature corrections cannot be neglected when tubulated gages are used at, or are attached to, chambers which operate over wide temperature ranges. Such errors are not to be confused with temperature effects on contaminant sorption, desorption, or condensation. At the gage calibration temperature conditions, the sensor has known operational constants. The determination of a pressure at significantly different temperatures other than the calibration conditions requires appropriate correction. Examples of temperature corrections are presented in Appendix X2.

8. Gage Correction for Gas Composition

8.1 Since an ionization vacuum gage is a device that provides an ion current derived from all the species present with different gage factors for each, it is possible the resulting ion current may be derived substantially from species other than nitrogen, the most typical calibrating gas. Provided both the percentage of other gases and the appropriate gage factors are known, the indicated gage reading can be normalized to provide corrected concentration or pressure values.

8.2 Data Reduction:

8.2.1 By applying known gage sensitivity factors the contribution of each gas being ionized can be accounted for within the total ion current. Generally the sensitivity of the gage for other gases is presented as the ratio of the sensitivity based on nitrogen being 1. The change in sensitivities as a first approximation is proportional to the difference in ionization probability for the gases involved. It should be remembered nitrogen simply serves as a convenient reference gas for pressure or concentration calibrations.

8.2.2 The precision of the correction is directly related to the validity of the sensitivity factors used for the particular gage involved. See Appendix X1 for a method for measuring or estimating sensitivity factors.

NOTE 2—When specific sensitivity factors are otherwise unavailable, one may use values such as those given in Refs (1) and (2).³ If corrected pressures or concentrations are reported, the user should clearly indicate the sensitivity factors used for performing the correction. An illustration of the method of calculating true total pressure from the ion current reading and the relative gas composition as given by a vacuum gas analyzer (VGA) is given as follows:

³ The boldface numbers in parentheses refer to the list of references at the end of this practice.

Ion current from gage = 1.0×10^{-8} A (from test)

Gage sensitivity for nitrogen = 10^{-1} A·N/m² = K_{N_2}

Gas composition in chamber = 80 % He, 10 % A, 10 % N₂ (relative composition from VGA).

Relative gage sensitivity factors:

$$K_{He}/K_{N_2} = 0.2, K_A/K_{N_2} = 1.3, K_{N_2}/K_{N_2} = 1.0$$

$$P_{He} + P_A + P_{N_2} = P_T \text{ or } (n_{He} + n_A + n_{N_2})$$

$$= P_{He}K_{He} + P_AK_A + P_{N_2}K_{N_2} = P_TK_T = 1.0 \times 10^{-8} \text{ A}$$

P_T = true total pressure, P_{N_2} = true partial pressure of nitrogen

$$\frac{P_{He}}{P_T} \frac{K_{He}}{K_{N_2}} + \frac{P_A}{P_T} \frac{K_A}{K_{N_2}} + \frac{P_{N_2}}{P_T} = \frac{K_T}{K_{N_2}} \quad (2)$$

$$0.8 \times 0.2 + 0.1 \times 1.3 + 0.1 = K_T/10^{-1}$$

$$K_T = (0.16 + 0.13 + 0.1) 10^{-1} \text{ A·N/m}^2$$

$$K_T = 3.9 \times 10^{-1} \text{ A·N/m}^2$$

$$P_T = (1.0 \times 10^{-8})/3.9 \times 10^{-2} \text{ N/m}^2 = 2.6 \times 10^{-7} \text{ N/m}^2 = \text{true total pressure}$$

$$P_{N_2} = (\text{equivalent}) = (1.0 \times 10^{-8})/10^{-1} \text{ N/m}^2$$

$$= 1.0 \times 10^{-7} \text{ N/m}^2$$

= equivalent nitrogen pressure

9. Determination of Gas Composition

9.1 Determination of the gas composition in a vacuum chamber is obtained by use of special simplified mass spectrometers vacuum gas analyzer (VGA) to separate and determine the amount of the various molecular species present. These devices can be calibrated to indicate the absolute amount of a given species being detected and thus serve as a partial pressure gage. For gage correction only the relative distribution is needed.

NOTE 3—Methods of calibration and application of vacuum gas analyzers are now in preparation by Committee E-21.

10. Operating Criteria

10.1 *Electronic Adjustment*—Upon achievement of a high vacuum condition in the working volume, the gage shall be turned on and appropriate adjustment of the emission current made to correspond with the calibration conditions. This setting should be periodically checked throughout the test as should the meter zero(s) before and during the gage operation.

10.2 *Continuous Operating Criteria*—Once the gage has been turned on (both hot- and cold-cathode gages) the gage should remain on continuously throughout the test. Exception may have to be made for short periods to check meter zeros.

10.3 *Degas*—Degas of the gage should be performed in a manner that has previously been checked while the gage is on the calibration test stand. For reestablishment of equilibrium conditions, comparable with the calibration conditions, it is essential the waiting period following degas corresponds to the gage recovery time or longer before using the indicated readings. Degas should be used when sorption of high or low molecular weight materials may have occurred. It is not recommended degassing of the gage be periodically or automatically used since the recovery time may extend for many hours under certain circumstances.

10.4 *Method of Degas*—Available methods of degas consist of electron bombardment heating, resistive heating of the grid structures, or bakeout of the gage with or without simultaneous bakeout of the system, or a combination of these. The processes should be in accordance with the recommended proce-

dures of the equipment manufacturer, if specified, or should be developed in conjunction with the calibration activity and determination of the gage recovery time. In general, note that typical recovery times for nude ionization gages are generally quite short (minutes) as compared to those of enclosed gages.

11. Heavy Molecular Weight Contamination Effects

11.1 *Transient Effects*:

11.1.1 Discrepancy between readings of nude and tubulated gages on the same system has been shown to be particularly high where the residual atmosphere is largely of high molecular weight—as outgas products from test specimens, lubricants, or vapors of vacuum pump fluids. Partial pressure analysis of the chamber atmosphere can warn that the situation is likely, but can do nothing to allow quantitative correction for it, because the tubulated ion gage is to a large extent generating its own atmosphere (Blears effect).

11.1.2 *Decontamination*—Where operation of test system, specimen, and gage have permitted a film of condensable material to coat the gage envelope or supporting structure, the gage should be vacuum baked mildly to evaporate such material before any outgassing by electron bombardment. This will avoid deposit of carbon or resinous films.

11.1.3 *Reading the Gage Following Degas*—In ultrahigh vacuum systems, and again where heavy molecules make up a large proportion of the residual atmosphere, whether outgas products or diffusion pump fluids in untrapped or poorly trapped systems, the time required for an outgassed gage to reach an equilibrium with the chamber to which it is attached may be hours or days, depending on geometry. For example, a gage attached by a 2-in. (50-mm) diameter tube, 8 in. (200 mm) long, to a test dome at equilibrium with silicone oil vapor at room temperature, requires 6 to 8 h after outgassing to reach a final reading of 3×10^{-7} N/m² (2×10^{-9} torr). Immediately after outgassing, the reading may be 7×10^{-8} N/m² (5×10^{-10} torr). The delay is, of course, due to adsorption of fluid vapor on the clean walls of the tubulation. The ion gage reading levels only after the adsorption capacity of the wall is satisfied.

11.1.4 *Temperature Effects*—Where heavy vapors are permitted in the vicinity of the ion gage at partial pressures near saturation for temperatures found at the gage wall or on gage support structures, a drop in temperature of only a few degrees may lower the pressure reading by factors of two to five. This temperature effect outweighs many others because of the severe dependence of saturation pressure on temperature for heavy molecules. To illustrate, for a material whose vapor pressure at room temperature is 10^{-5} N/m² (10^{-7} torr), a rise of 5K approximately doubles the vapor pressure. Such effects may or may not be transient, depending on circumstances.

11.2 *Permanent Effects*—Permanent change in gage calibration can result when deposits of carbonaceous or resinous material in the gage occur. Their effect may be to provide a conductive leakage path over insulators, to reduce emission of coated cathodes, or to permit buildup of charges that distort normal electrical fields. Appearance of these conditions is to be anticipated where (1) the gage operates in vapor partial pressures of 10^{-3} N/m² (10^{-5} torr) and higher; or (2) relatively cool gage surfaces promote condensation of fluids, or mishandling of vacuum systems allows similar physical contamination

by liquids to occur. Calibration change can be suspected when (1) a leakage path is found between electrodes of the gage tube, with control disconnected; (2) response of collector current to grid current becomes nonlinear in a range of grid currents where it is normally linear; or (3) the walls of the envelope or electrodes become discolored.

12. Apparent X-Ray Limit for Hot-Cathode Gages

12.1 Sorption Effects:

12.1.1 *General*—Redhead (3), Schuemann (4), and others have shown that hot-cathode ionization gages can exhibit abnormally high readings as a result of the electron desorption of previously adsorbed gas from the gage elements, especially the grid. For oxygen (and possible other electronegative gases), this effect is very pronounced. It has also been shown that these effects may take hours to disappear, depending on the degree of surface contamination and other variables. As the system pressure is reduced to lower and lower values, the uncertainty in reading because of these desorption problems becomes more critical. At present, there is no known method of evaluating the absolute magnitude of such errors (except in the laboratory) so that “true” pressure may be determined. The best that can be done under normal operating situations is to observe certain gage characteristics which are a function of gage cleanliness and therefore its accuracy.

12.1.2 Useful Tests:

12.1.2.1 Assuming that the grid of any hot-cathode ionization gage is perfectly free of adsorbed gas, the observed ion current should be linearly related to the electron emission current. This fact may be used to test gage cleanliness at low pressures and therefore to serve as a means of evaluating the pressure readings. If the emission current is varied by at least a factor of ten, the observed ion current should vary by precisely the same factor (if the gage operates in a normal manner). If however, the observed ion current is seen to increase to values much larger than the factor by which the grid current was increased, the grid is probably dirty and requires further outgassing. Note that in tubulated gages the increase in filament temperature at higher emission currents will cause the bulb temperature to rise and therefore to desorb more gas. It is, therefore, important in this test to change the emission *quickly* to prevent bulb temperature changes from influencing the readings.

12.1.2.2 Further information on gage cleanliness can be obtained by observing the ion current as a function of time immediately after outgassing a tubulated gage. If the observed ion current is seen to reach a minimum value, and then to stabilize at a slightly higher value, the stable value is more nearly proportional to system pressure. Before the equilibrium value was reached, the grid probably pumped the tubulated gage to pressures slightly lower than the system. If the observed pressure is seen to rise continuously with time, the grid is probably being contaminated by the vacuum system. This effect is often quite pronounced in nude gages.

12.1.2.3 Again, it must be emphasized that the above procedures do not guarantee accurate readings. They only provide supporting information useful in approximate estimates of system conditions.

12.2 Modulator Methods:

12.2.1 *General*—The modulated hot-cathode ion gage was originally proposed by Redhead (5) as a means of distinguishing the true ion current from the X-ray-induced secondary emission current at the ion collector. This original work recognized the existence of only two currents at the gage ion collector. The first current was thought to be only the ion current resulting from the normal ionization of molecules residual to the gage. The second current was due to the familiar X-ray background previously described. It was originally believed that the modulation method would separate these two currents. Subsequently, Redhead found that the presence of adsorbed gases on the grid (such as oxygen) produced further anomalies which the modulator method cannot separate. Therefore, in the presence of these adsorbed gases, no true system pressure can be measured by this method. Once one has proven the true X-ray limit of a particular gage, the modulator method is useful in detecting gage contamination by noting the difference between the true X-ray limit and the observed residual current determined by the modulation technique. In general, the use of a modulated gage will NOT ensure unambiguous system pressure measurement.

12.2.2 *Useful Tests*—The tests outlined under 12.1.2 may also be applied to any modulated gage.

13. Gage Factors—Cold-Cathode Gages

13.1 *General*—Cold-cathode gages are divided into two general categories. The first group are commonly called Philips or Penning gages and are useful from approximately 1 to 10^{-5} N/m² (10^{-2} to 10^{-7} torr). The second group are called Redhead or Magnetron gages and are useful from 10^{-4} to 10^{-8} N/m² (10^{-6} to 10^{-10} torr) and below. In general, both categories are characterized by high sensitivity, wide dynamic range, and simplicity of operation. Since any particular design may have its own detailed problems, only general discussions of these problems can be presented.

13.2 *Use of Cold-Cathode Gages*—All gages of this type exhibit certain characteristics which must be remembered in using these gages.

13.2.1 Pumping speed is high for active gases, and sensitivity is a function of the two operating parameters, anode voltage and magnetic field. The gage may exhibit nonlinear responses at the upper and lower limits of its operating range. Contamination is a problem since no means is provided for degassing the gage by internal heating or hot-filament electron bombardment. Degassing does occur as a result of the high voltage discharge, and the rate can be increased by increasing the voltage. The gage manufacturer should be consulted to determine voltage limitations and for recommended procedures. The continuous operation criteria of 10.2 should be followed with high voltage being continuously applied to the gage.

13.2.2 The large pumping speed of these gages requires the use of large-diameter (1 in. (25 mm) or greater) tubulation to the gage. This tubulation must be as short as possible (less than 4 in. (100 mm)). In any case, the calculated conductance of the tubulation should be not less than ten times the pumping speed of the gage for active gases such as nitrogen.