

ISO/TC 34/SC 7

Secretariat: BIS

Voting begins on:
2020-09-21

Voting terminates on:
2020-11-16

Spices and condiments — Determination of moisture content

Épices et condiments — Détermination de la teneur en eau

iTeh STANDARD PREVIEW
(standards.iteh.ai)
Full standard:
<https://standards.iteh.ai/catalog/standards/sist/87846e25-d692-4ccf-a5de-c42738e52acd/iso-fdis-939>

RECIPIENTS OF THIS DRAFT ARE INVITED TO SUBMIT, WITH THEIR COMMENTS, NOTIFICATION OF ANY RELEVANT PATENT RIGHTS OF WHICH THEY ARE AWARE AND TO PROVIDE SUPPORTING DOCUMENTATION.

IN ADDITION TO THEIR EVALUATION AS BEING ACCEPTABLE FOR INDUSTRIAL, TECHNOLOGICAL, COMMERCIAL AND USER PURPOSES, DRAFT INTERNATIONAL STANDARDS MAY ON OCCASION HAVE TO BE CONSIDERED IN THE LIGHT OF THEIR POTENTIAL TO BECOME STANDARDS TO WHICH REFERENCE MAY BE MADE IN NATIONAL REGULATIONS.



Reference number
ISO/FDIS 939:2020(E)

iTeh STANDARD PREVIEW
(standards.iteh.ai)
Full standard:
<https://standards.iteh.ai/catalog/standards/sist/87846e25-db92-4ccf-a5de-c42738e52acd/iso-fdis-939>



COPYRIGHT PROTECTED DOCUMENT

© ISO 2020

All rights reserved. Unless otherwise specified, or required in the context of its implementation, no part of this publication may be reproduced or utilized otherwise in any form or by any means, electronic or mechanical, including photocopying, or posting on the internet or an intranet, without prior written permission. Permission can be requested from either ISO at the address below or ISO's member body in the country of the requester.

ISO copyright office
CP 401 • Ch. de Blandonnet 8
CH-1214 Vernier, Geneva
Phone: +41 22 749 01 11
Email: copyright@iso.org
Website: www.iso.org

Published in Switzerland

Contents

	Page
Foreword	iv
1 Scope	1
2 Normative references	1
3 Terms and definitions	1
4 Principle	1
5 Reagents	1
6 Apparatus	2
7 Sampling	2
8 Procedure	2
8.1 Preparation of apparatus	2
8.2 Preparation of test sample	2
8.3 Test portion	2
8.4 Determination	2
9 Expression of results	3
10 Test report	3
Annex A (informative) Example of entrainment distillation apparatus	4

iTeh STANDARD PREVIEW
 (standards.iteh.ai)
 Full standard:
<https://standards.iteh.ai/catalog/standards/sist/8765e25-d692-4ccf-a5de-c42738e52acd/iso-fdis-939>

Foreword

ISO (the International Organization for Standardization) is a worldwide federation of national standards bodies (ISO member bodies). The work of preparing International Standards is normally carried out through ISO technical committees. Each member body interested in a subject for which a technical committee has been established has the right to be represented on that committee. International organizations, governmental and non-governmental, in liaison with ISO, also take part in the work. ISO collaborates closely with the International Electrotechnical Commission (IEC) on all matters of electrotechnical standardization.

The procedures used to develop this document and those intended for its further maintenance are described in the ISO/IEC Directives, Part 1. In particular, the different approval criteria needed for the different types of ISO documents should be noted. This document was drafted in accordance with the editorial rules of the ISO/IEC Directives, Part 2 (see www.iso.org/directives).

Attention is drawn to the possibility that some of the elements of this document may be the subject of patent rights. ISO shall not be held responsible for identifying any or all such patent rights. Details of any patent rights identified during the development of the document will be in the Introduction and/or on the ISO list of patent declarations received (see www.iso.org/patents).

Any trade name used in this document is information given for the convenience of users and does not constitute an endorsement.

For an explanation of the voluntary nature of standards, the meaning of ISO specific terms and expressions related to conformity assessment, as well as information about ISO's adherence to the World Trade Organization (WTO) principles in the Technical Barriers to Trade (TBT), see www.iso.org/iso/foreword.html.

This document was prepared by Technical Committee ISO/TC 34, *Food products*, Subcommittee SC 7, *Spices, culinary herbs and condiments*.

This second edition cancels and replaces the first edition (ISO 939:1980), which has been technically revised. The main changes compared with the previous edition are as follows:

- the Introduction has been deleted;
- definition [3.1](#) has been revised;
- in [8.1](#), “a potassium dichromatesulphuric acid cleaning solution” has been replaced by “a laboratory-grade detergent”;
- in [8.4](#), “asbestos cloth” has been replaced by “glass fibres, stone wool or ceramic fibres”;
- in [8.4](#), the instruction to immerse the receiver in water at room temperature has been changed from “15 min” to “45 min”;
- in [Annex A b](#)), the inner tube diameter has been changed from “9,5 to 12,5 mm” to “5 mm to 12,5 mm”.

Any feedback or questions on this document should be directed to the user's national standards body. A complete listing of these bodies can be found at www.iso.org/members.html.

Spices and condiments — Determination of moisture content

1 Scope

This document specifies an entrainment method for the determination of the moisture content of spices and condiments.

2 Normative references

The following documents are referred to in the text in such a way that some or all of their content constitutes requirements of this document. For dated references, only the edition cited applies. For undated references, the latest edition of the referenced document (including any amendments) applies.

ISO 948, *Spices and condiments — Sampling*

ISO 2825, *Spices and condiments — Preparation of a ground sample for analysis*

3 Terms and definitions

For the purposes of this document, the following terms and definitions apply.

ISO and IEC maintain terminological databases for use in standardization at the following addresses:

- ISO Online browsing platform: available at <https://www.iso.org/obp>
- IEC Electropedia: available at <http://www.electropedia.org/>

3.1

moisture content

content of water extracted or collected in accordance with the method prescribed in this document

Note 1 to entry: Moisture content is expressed as a percentage by mass.

4 Principle

Determination of the amount of water entrained by azeotropic distillation, using an organic liquid immiscible with water, and collected in a graduated tube.

5 Reagents

5.1 Toluene.

Saturate the toluene by shaking with a small quantity of water and distil. Use the distillate for the determination of the moisture.

NOTE Different solvents are used for the determination of moisture.

Unless otherwise specified in the International Standard giving specifications for the spice or condiment in question, toluene shall be the solvent used for the determination.

6 Apparatus

Distillation apparatus (a suitable form of apparatus is described in [Annex A](#) and shown in [Figure A.1](#)), comprising the following components fitted together by means of ground glass joints.

- 6.1 **Flask**, short-necked, of capacity at least 500 ml.
- 6.2 **Reflux condenser**.
- 6.3 **Receiver**, with a graduated tube, interposed between the flask and the condenser.
- 6.4 **Analytical balance**.

7 Sampling

Sample the material by the method specified in ISO 948.

8 Procedure

8.1 Preparation of apparatus

Clean the entire apparatus with a laboratory-grade detergent to minimize the adherence of water droplets to the sides of the condenser and the receiver.

Rinse thoroughly with water and dry completely before use.

8.2 Preparation of test sample

Prepare the test sample by the method specified in ISO 2825.

8.3 Test portion

Weigh, to the nearest 0,01 g, about 40 g of the test sample (see [8.2](#)), such that the quantity of water collected will not exceed 4,5 ml.

8.4 Determination

Transfer quantitatively the test portion (see [8.3](#)) to the distillation flask ([6.1](#)), add sufficient toluene ([5.1](#)) (about 75 ml in all) to cover the sample completely and swirl to mix. Assemble the apparatus and fill the receiver ([6.3](#)) with the toluene by pouring it through the condenser ([6.2](#)) until it begins to overflow into the distillation flask. If necessary, insert a loose cotton plug in the top of the condenser or attach to it a small calcium chloride tube to prevent condensation of atmospheric moisture within the condenser tube. In order to control refluxing, wrap the flask and tube leading to the receiver with glass fibres, stone wool or ceramic fibres. Heat the flask so that the distillation rate is about 100 drops per minute. When the greater part of the water has distilled over, increase the distillation rate to about 200 drops per minute and continue until no more water is collected. Purge the reflux condenser occasionally during the distillation with 5 ml portions of the toluene to wash down any moisture adhering to the walls of the condenser. The water in the receiver may be made to separate from the toluene by occasionally moving a spiral copper wire up and down in the condenser and receiver, thus causing the water to settle at the bottom of the receiver. Reflux until the water level in the receiver remains unchanged for 30 min and then shut off the source of heat.

Flush the condenser with toluene as required, making use of the spiral copper wire to discharge any moisture droplets. Immerse the receiver in water at room temperature for at least 45 min or until the toluene layer is clear. Then read the volume of water.

9 Expression of results

The moisture content (W), in percentage by mass, can be expressed by [Formula \(1\)](#):

$$W = \frac{100 \times V}{m} \quad (1)$$

where

V is the volume of water collected, in ml;

m is the mass of the test portion, in g.

It is assumed that the density of water is 1 g/ml exactly.

10 Test report

The test report shall show the method used and the result obtained. It shall also mention all operating conditions not specified in this document, or regarded as optional, as well as any circumstances that may have influenced the result.

The report shall include all details required for complete identification of the sample.

!Teh STANDARD PREVIEW
(standards.iteh.ai)
Full standard:
<https://standards.iteh.ai/catalog/standards/sist/87846e25-6922-4ccf-a5de-c42738e52acd/iso-fdis-939>

Annex A (informative)

Example of entrainment distillation apparatus

The apparatus consists of a glass flask heated by a suitable means and provided with a reflux condenser discharging into a receiver connected to the flask. The connections between the receiver, the condenser and the flask are interchangeable ground glass joints. The receiver serves to collect and measure the condensed water, and to return the solvent to the flask. The assembly of the apparatus is shown in [Figure A.1](#) and the various components are described below.

- a) Flask, of capacity 500 ml, made of heat-resistant glass, well annealed, as free as possible from striae and defects, and similar to the shape shown in [Figure A.1](#).
- b) Reflux condenser, water cooled, made of glass, having a jacket approximately 400 mm long and an inner tube of diameter 5 mm to 12,5 mm. The tip of the condenser to be inserted in the receiver may be ground off at an angle of 30° from the vertical axis of the condenser. When inserted into the receiver, the tip of the condenser is 6 mm to 7 mm above the surface of the liquid in the receiver after distillation conditions have been established.
- c) Receiver, of capacity 5 ml, made of heat-resistant glass, well annealed and as free as possible from striae and similar defects, provided with ground glass joints, with the shape, dimensions and tolerances given in [Figure A.1](#), and consisting essentially of the upper chamber, together with the tube and ground joint leading to the flask, and the graduated tube. The graduated portion has a capacity of 5 ml when filled to the highest graduation mark.

The scale covers the range of 0 ml to 5 ml and is graduated at intervals of 0,1 ml. The graduation marks corresponding to each millilitre are numbered and carried completely round the tube. The graduation marks midway between the numbered marks are carried three-quarter way, and the remaining marks are carried half-way, around the tube. The error at any indicated capacity does not exceed 0,05 ml.

- d) Heat source, either an oil bath or an electric heater provided with a sliding rheostat or other means of heat control.

The temperature of the oil in the bath should not be very much higher than the boiling point of toluene.

- e) Copper wire, long enough to extend through the condenser and with one end twisted into a spiral. The diameter of the spiral is such that it fits snugly within the graduated portion of the receiver and yet can be moved up and down.

Dimensions in millimetres

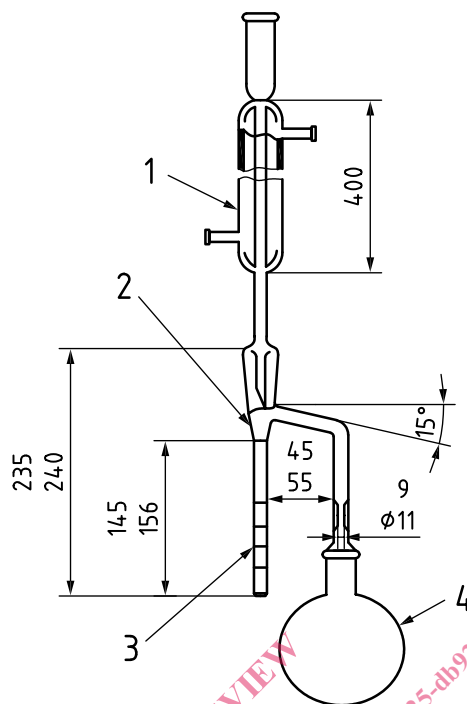

Key

- 1 reflux condenser (6.2)
- 2 receiver (6.3)
- 3 graduated tube
- 4 flask (6.1)

NOTE Volume: 5 ml, graduations: 0,10 ml.

Figure A.1 — Assembly of the entrainment distillation apparatus