International Standard



2344

INTERNATIONAL ORGANIZATION FOR STANDARDIZATION • МЕЖДУНАРОДНАЯ ОРГАНИЗАЦИЯ ПО СТАНДАРТИЗАЦИИ • ORGANISATION INTERNATIONALE DE NORMALISATION

Road vehicles — Spark plugs M 14 × 1,25 with conical seating and their cylinder head housing

Véhicules routiers — Bougies d'allumage M 14 × 1,25 à siège conique et leur logement dans la culasse

Fourth edition — 1981-05-15

iTeh STANDARD PREVIEW
(standards.iteh.ai)

ISO 2344:1981

<https://standards.iteh.ai/catalog/standards/sist/6f6e6950-3fe5-4d54-abd9-730de1e6ff6f/iso-2344-1981>

UDC 621.43.045

Ref. No. ISO 2344-1981 (E)

Descriptors : road vehicles, motor vehicles, internal combustion engines, ignition systems, spark plugs, conical components, threaded mechanical parts, screw threads, dimensions, dimensional tolerances.

Price based on 4 pages

Foreword

ISO (the International Organization for Standardization) is a worldwide federation of national standards institutes (ISO member bodies). The work of developing International Standards is carried out through ISO technical committees. Every member body interested in a subject for which a technical committee has been set up has the right to be represented on that committee. International organizations, governmental and non-governmental, in liaison with ISO, also take part in the work.

Draft International Standards adopted by the technical committees are circulated to the member bodies for approval before their acceptance as International Standards by the ISO Council.

International Standard ISO 2344 was developed by Technical Committee ISO/TC 22, *Road vehicles*.

This fourth edition was submitted directly to the ISO Council, in accordance with clause 5.10.1 of part 1 of the Directives for the technical work of ISO. It cancels and replaces the third edition (i.e. ISO 2344-1976), which had been approved by the member bodies of the following countries :

Australia	Iran	Spain
Austria	Ireland	Sweden
Belgium	Italy	Switzerland
Brazil	Japan	Turkey
Bulgaria	Korea, Dem. P. Rep. of	United Kingdom
Chile	Netherlands	USSR
France	Poland	Yugoslavia
Germany, F. R.	Romania	
Hungary	South Africa, Rep. of	

The member body of the following country had expressed disapproval of the document on technical grounds :

USA

Road vehicles — Spark plugs M 14 × 1,25 with conical seating and their cylinder head housing

1 Scope

This International Standard specifies the main dimensional characteristics of a spark plug type used with spark ignition engines.

2 Field of application

The provisions of this International Standard apply to spark plugs M 14 × 1,25 with conical seating with a normal or long reach and to their cylinder head housing.

3 References

ISO 68, *ISO general purpose screw threads — Basic profile.*

ISO 261, *ISO general purpose metric screw threads — General plan.*

ISO 965/1, *ISO general purpose metric screw threads — Tolerances — Part 1 : Principles and basic data.*

ISO 965/3, *ISO general purpose metric screw threads — Tolerances — Part 3 : Deviations for constructional threads.*

4 Required characteristics

4.1 Terminals (see figure 3 and annex)

The preferred type is the solid post terminal.

The threaded terminal with nut is permitted (see annex).¹⁾

Engine manufacturers are encouraged to introduce solid post terminals in practice.

4.2 Dimensions and thread (see figures 1 and 2)

4.2.1 Plug reach and cylinder head thread length dimensions

Values in millimetres

Type of reach	A	B max.	Y	Z min.
Normal reach	11,2 ± 0,3	19	10,2 ± 0,3	10,8
Long reach	17,5 ± 0,3	25	16,5 ± 0,3	17,1

4.2.2 Length dimensions²⁾

The length dimensions are measured from a gauging plane defined by diameter $\boxed{14,8}$ on the seating.

4.2.3 Dimensions of spark plug housing in the cylinder head

The length dimensions Z and 5,5 max.²⁾ in the cylinder head are measured from a gauging plane defined by diameter $\boxed{14,8}$ on the seating.

Dimension Z shall ensure that no threaded portion of the plug reach may enter the combustion chamber when the spark plug is tightened with the torque specified in 4.4.

1) This permission will be re-examined in 5 years.

2) After the reduction of dimension 7,2 max. to 5,5 max. in November 1973 a reduction of dimension 8,2 min. of the long reach spark plug to 6,5 min. will be considered in 1985. It will also be considered whether this latter modification shall also apply to the normal reach spark plug and whether dimensions 63 max. might be changed.

4.2.4 Thread

4.2.4.1 Dimension limits

Values in millimetres

Dimension		Plug thread (on finished plug) 6e	Tapped hole in cylinder head 6H
Major diameter	max.	13,937	not specified
	min.	13,725	14,000
Pitch diameter	max.	13,125	13,368
	min.	12,993	13,188
Minor diameter	max.	12,404	12,912
	min.	12,181*	12,647

* With a root radius > 0,125 mm (0,1 P).

4.2.4.2 Tolerance classes

The tolerance classes of thread M 14 × 1,25 of finished spark plugs and of the corresponding tapped holes in the cylinder head are as follows :

- 6e for spark plugs (see note 2);
- 6H for tapped holes in the cylinder head.

NOTES

1 The threads M 14 × 1,25 of the spark plugs and the corresponding tapped holes in the cylinder head shall conform to ISO 68, ISO 261, ISO 965/1 and ISO 965/3.

2 In order that the spark plugs complying with this International Standard can be fitted in existing cylinder heads also in limiting cases, the value for the *upper limiting profile* of the minor diameter of the spark plug base has been slightly reduced with respect to the ISO value.

This maximum value of the minor diameter was calculated from a distance of $H/6$ for the *upper limiting profile* instead of $3 H/16$ given in

figure 6 of ISO 965/1, clause 10, according to the formula given below :

$$\begin{aligned} \text{minor diameter max.} &= d_1 - es - 2(H/4 - H/6) \\ &= 12,647 - 0,063 - 0,180 \\ &= 12,647 - 0,243^{1)} = 12,404 \end{aligned}$$

The value for the *basic profile* remains the same as for the ISO thread (12,647 - 0,063 = 12,584).

3 The initial clearance $e = 0,063$ mm between the pitch diameters of the thread and of the tapped hole is intended to prevent the possibility of seizure, as a result of combustion deposits on the bare threads, when removing the spark plugs.

This clearance is also intended to enable spark plugs with threads in accordance with this International Standard to be fitted in existing tapped holes.

4.3 Other dimensions of the spark plug and the housing in the cylinder head

The other dimensions are indicated in figures 1, 2 and 3.

The contour of the insulator is optional, however, between the reference lines defined by the dimensions 29 and 33 mm, its largest diameter shall be $10,5 \pm 0,3$ mm.

Details not specified are left to the manufacturer's choice.

4.4 Installation tightening torque

The installation torque values apply to new spark plugs without lubricant on the threads. If threads are lubricated, the torque value shall be reduced by approximately 1/3 to avoid oversteering.

The spark plugs shall be tightened with a torque of :

10 to 20 N·m in aluminium and cast iron cylinder heads.

NOTE — Engine manufacturers may specify a different torque for the first spark plug installation.

1) This value is given in ISO 965/3 for the minor diameter.

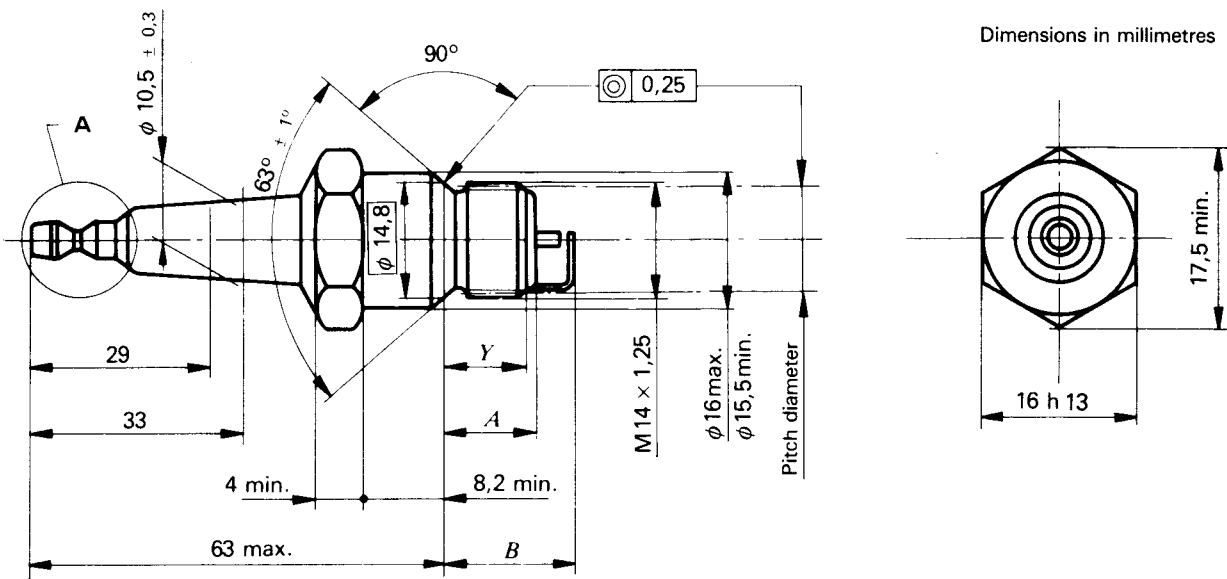

Figure 1 — Spark plug M 14 × 1,25 with conical seating

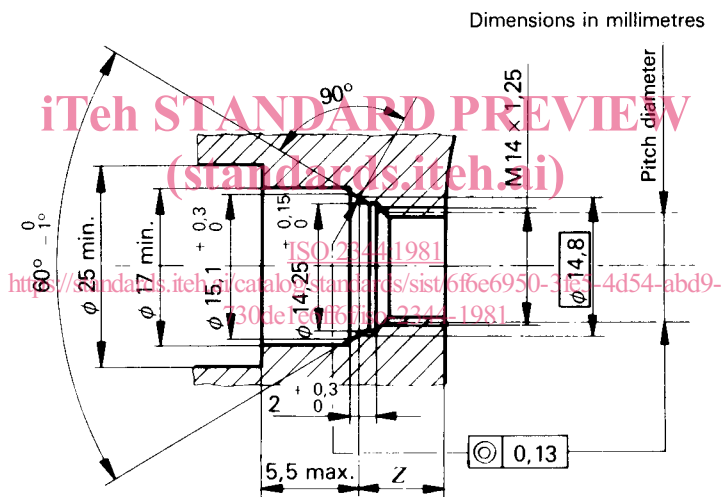

Figure 2 — Housing of the spark plug in the cylinder head

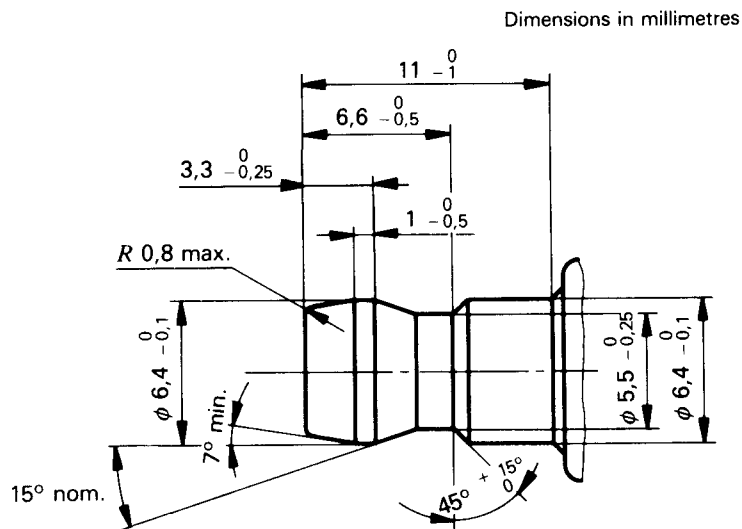

Figure 3 — Solid post terminal (detail A of figure 1)

Annex

Threaded terminal

The external dimensions of the nuts shall be the same as those for the solid post terminal.

The internal dimensions of the nuts are left to the manufacturer's choice.

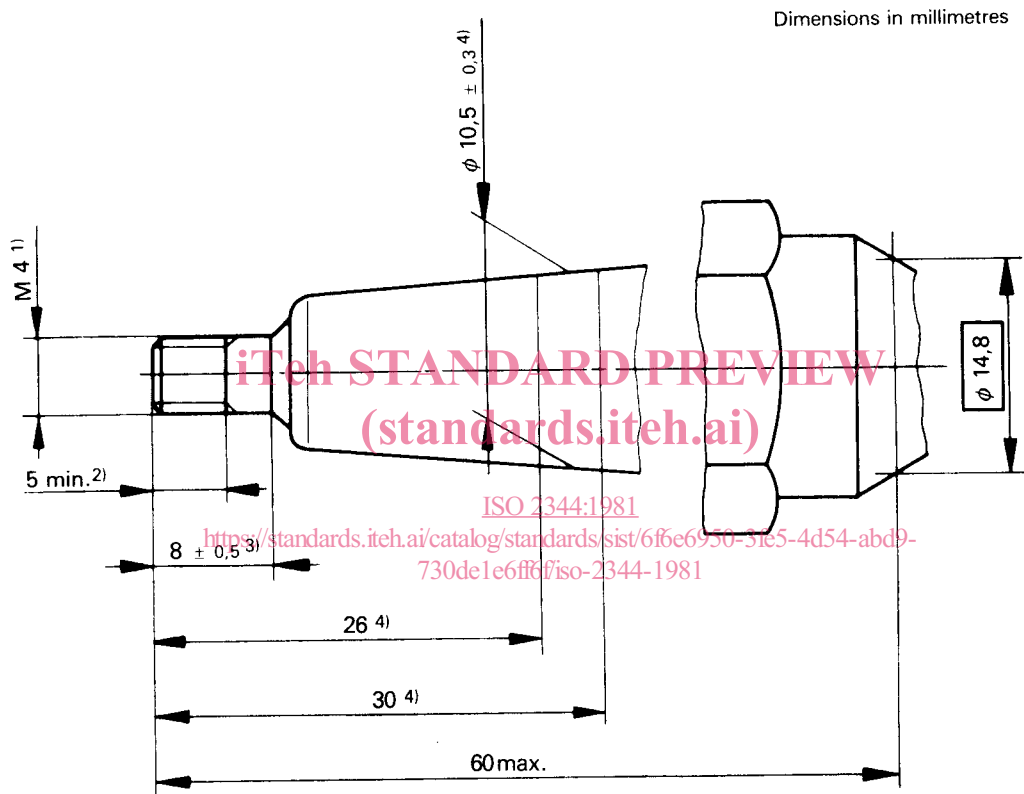

Figure 4 – Threaded terminal

The dimension 60 max. is measured from a gauging plane defined by diameter 14,8 on the seating.

- 1) 0,7 mm pitch complying with ISO 68 and with ISO 261.
- 2) Length of usable thread.
- 3) Cylindrical part.
- 4) The contour of the insulator is optional; however, between the reference lines defined by the dimensions 26 and 30 mm, its largest diameter shall be $10,5 \pm 0,3$ mm.

iTeh STANDARD PREVIEW
(standards.iteh.ai)

ISO 2344:1981

<https://standards.iteh.ai/catalog/standards/sist/6f6e6950-3fe5-4d54-abd9-730de1e6ff6f/iso-2344-1981>

iTeh STANDARD PREVIEW
(standards.iteh.ai)

ISO 2344:1981

<https://standards.iteh.ai/catalog/standards/sist/6f6e6950-3fe5-4d54-abd9-730de1e6ff6f/iso-2344-1981>