



Designation: D7332/D7332M-07^{ε1} Designation: D7332/D7332M – 09

Standard Test Method for Measuring the Fastener Pull-Through Resistance of a Fiber-Reinforced Polymer Matrix Composite¹

This standard is issued under the fixed designation D7332/D7332M; the number immediately following the designation indicates the year of original adoption or, in the case of revision, the year of last revision. A number in parentheses indicates the year of last reapproval. A superscript epsilon (ϵ) indicates an editorial change since the last revision or reapproval.

^{ε1}Note—In the last sentence of 6.4, +75/-0 mm was editorially changed to +75/-0 μm in August 2009.

1. Scope

1.1 This test method determines the fastener pull-through resistance of multidirectional polymer matrix composites reinforced by high-modulus fibers. Fastener pull-through resistance is characterized by the force-versus-displacement response exhibited when a mechanical fastener is pulled through a composite plate, with the force applied perpendicular to the plane of the plate. The composite material forms are limited to continuous-fiber or discontinuous-fiber (tape or fabric, or both) reinforced composites for which the laminate is symmetric and balanced with respect to the test direction. The range of acceptable test laminates and thicknesses is defined in 8.2.

1.2 Two test procedures and configurations are provided. The first, Procedure A, is suitable for screening and fastener development purposes. The second, Procedure B, is configuration-dependent and is suitable for establishing design values. Both procedures can be used to perform comparative evaluations of candidate fasteners/fastener system designs.

1.3 The specimens described herein may not be representative of actual joints which may contain one or more free edges adjacent to the fastener, or may contain multiple fasteners that can change the actual boundary conditions.

1.4 This test method is consistent with the recommendations of CMH-17, which describes the desirable attributes of a fastener pull-through test method.

1.5 The values stated in either SI units or inch-pound units are to be regarded separately as standard. Within the text the inch-pound units are shown in brackets. The values stated in each system are not exact equivalents; therefore, each system must be used independently of the other. Combining values from the two systems may result in nonconformance with the standard.

1.6 *This standard does not purport to address all of the safety concerns, if any, associated with its use. It is the responsibility of the user of this standard to establish appropriate safety and health practices and determine the applicability of regulatory limitations prior to use.*

2. Referenced Documents

2.1 ASTM Standards:²

D792 Test Methods for Density and Specific Gravity (Relative Density) of Plastics by Displacement

D883 Terminology Relating to Plastics

D3171 Test Methods for Constituent Content of Composite Materials

D3410/D3410M Test Method for Compressive Properties of Polymer Matrix Composite Materials with Unsupported Gage Section by Shear Loading

D3878 Terminology for Composite Materials

D5229/D5229M Test Method for Moisture Absorption Properties and Equilibrium Conditioning of Polymer Matrix Composite Materials

D5687/D5687M Guide for Preparation of Flat Composite Panels with Processing Guidelines for Specimen Preparation

E4 Practices for Force Verification of Testing Machines

E6 Terminology Relating to Methods of Mechanical Testing

E18 Test Methods for Rockwell Hardness of Metallic Materials

¹ This test method is under the jurisdiction of ASTM Committee D30 on Composite Materials and is the direct responsibility of Subcommittee D30.05 on Structural Test Methods.

Current edition approved March 15, 2007. Published April 2007. DOI: 10.1520/D7332_D7332M-07E01.

Current edition approved Sept. 1, 2009. Published October 2009. Originally approved in 2007. Last previous edition approved in 2007 as D7332/D7332M-07^{ε1}. DOI: 10.1520/D7332_D7332M-09.

² For referenced ASTM standards, visit the ASTM website, www.astm.org, or contact ASTM Customer Service at service@astm.org. For Annual Book of ASTM Standards volume information, refer to the standard's Document Summary page on the ASTM website.



E122 Practice for Calculating Sample Size to Estimate, With Specified Precision, the Average for a Characteristic of a Lot or Process

E177 Practice for Use of the Terms Precision and Bias in ASTM Test Methods

E456 Terminology Relating to Quality and Statistics

E1309 Guide for Identification of Fiber-Reinforced Polymer-Matrix Composite Materials in Databases

E1434 Guide for Recording Mechanical Test Data of Fiber-Reinforced Composite Materials in Databases

2.2 Industry Documents:

CMH-17-1F Composite Materials Handbook, Volume 1—Polymer Matrix Composites Guidelines for Characterization of Structural Materials³

3. Terminology

3.1 *Definitions*—Terminology D3878 defines terms relating to composite materials. Terminology D883 defines terms relating to plastics. Terminology E6 defines terms relating to mechanical testing. Terminology E456 and Practice E177 define terms relating to statistics. In the event of a conflict between terms, Terminology D3878 shall have precedence over the other standards.

NOTE 1—If the term represents a physical quantity, its analytical dimensions are stated immediately following the term (or letter symbol) in fundamental dimension form, using the following ASTM standard symbology for fundamental dimensions, shown within square brackets: $[M]$ for mass, $[L]$ for length, $[T]$ for time, $[\theta]$ for thermodynamic temperature, and $[nd]$ for non-dimensional quantities. Use of these symbols is restricted to analytical dimensions when used with square brackets, as the symbols may have other definitions when used without the brackets.

3.2 Definitions of Terms Specific to This Standard:

3.2.1 *diameter-to-thickness ratio, D/h [nd], n* —the ratio of the hole diameter to the specimen thickness.

3.2.1.1 *Discussion*—The diameter-to-thickness ratio may be either a nominal value determined from nominal dimensions or an actual value determined from measured dimensions.

3.2.2 *failure force, n* —the maximum force magnitude achieved prior to the first significant (greater than 10 %) drop in applied force, as observed in force versus displacement data.

3.2.3 *initial sub-critical failure, n* —discontinuity observed in force versus displacement data prior to attaining the failure force. Sub-critical failures are characterized by minor (less than 10 %) drops in applied force, or by compliance changes (greater than 10 % change in slope), prior to attaining the failure force.

3.2.4 *nominal value, n* —a value, existing in name only, assigned to a measurable property for the purpose of convenient designation. Tolerances may be applied to a nominal value to define an acceptable range for the property.

3.2.5 *principal material coordinate system, n* —a coordinate system with axes that are normal to the planes of symmetry inherent to a material.

3.2.5.1 *Discussion*—Common usage, at least for Cartesian axes (123, xyz , and so forth), generally assigns the coordinate system axes to the normal directions of planes of symmetry in order that the highest property value in a normal direction (for elastic properties, the axis of greatest stiffness) would be 1 or x , and the lowest (if applicable) would be 3 or z . Anisotropic materials do not have a principal material coordinate system due to the total lack of symmetry, while, for isotropic materials, any coordinate system is a principal material coordinate system. In laminated composites, the principal material coordinate system has meaning only with respect to an individual orthotropic lamina. The related term for laminated composites is “reference coordinate system.”

3.2.6 *reference coordinate system, n* —a coordinate system for laminated composites used to define ply orientations. One of the reference coordinate system axes (normally the Cartesian x -axis) is designated the reference axis, assigned a position, and the ply principal axis of each ply in the laminate is referenced relative to the reference axis to define the ply orientation for that ply.

3.2.7 *rupture, n* —separation of the fastener and test laminate, caused by failure of the fastener, the composite plate, or both. Rupture is characterized by an extreme force drop, such that the specimen is incapable of carrying significant applied force.

3.2.8 *specially orthotropic, adj* —a description of an orthotropic material as viewed in its principal material coordinate system. In laminated composites, a specially orthotropic laminate is a balanced and symmetric laminate of the $[0_i/90_j]_{ns}$ family as viewed from the reference coordinate system, such that the membrane-bending coupling terms of the laminate constitutive relation are zero.

3.3 Symbols:

A = cross-sectional area of a specimen

CV = coefficient of variation statistic of a sample population for a given property (in percent)

d = fastener or pin shank diameter

d_{csk} = countersink depth

D = specimen hole diameter

h = specimen thickness

l = specimen length

n = number of specimens per sample population

N = number of plies in laminate under test

³ Available from U.S. Army Research Laboratory, Materials Directorate, Aberdeen Proving Ground, MD 21001.

P_f = failure force

P_i = force carried by test specimen at initial failure

P_m = maximum force carried by test specimen during test

s_{n-1} = standard deviation statistic of a sample population for a given property

w = specimen width

x_i = test result for an individual specimen from the sample population for a given property

\bar{x} = mean or average (estimate of mean) of a sample population for a given property

δ_i = displacement at initial failure

δ_r = displacement at rupture

4. Summary of Test Method

4.1 Procedure A, Compressive-Loaded Fixture:

4.1.1 Two flat square, constant rectangular cross-section composite plates, each containing a centrally located fastener hole, are placed in a multi-piece fixture that has been aligned to minimize loading eccentricities. Each plate contains four additional holes on the periphery to accommodate the test fixture components. The two plates are joined together by the fastener, with one plate being rotated 45° with respect to the second plate.

4.1.2 The plates are pried apart by the application of compressive force transmitted through the fixture, producing a tensile loading through the fastener and a compressive loading through the composite plates. Force is applied until failure of the composite specimen, the fastener, or both occurs. Applied force and crosshead displacement are recorded while loading.

4.2 Procedure B, Tensile-Loaded Fixture:

4.2.1 A flat square, constant rectangular cross-section composite plate containing a centrally located fastener hole is placed in a multi-piece fixture that has been aligned to minimize loading eccentricities. The plate is joined by the fastener to a yoke, which is designed to rotate as to avoid imparting a moment to the fastener.

4.2.2 A uniaxial tensile force is applied to the yoke, imparting a tensile loading on the fastener and an out-of-plane compressive loading on the composite plate. Force is applied until failure of the composite specimen, the fastener, or both occurs. Applied force and crosshead displacement are recorded while loading.

4.3 For both procedures, preferred failure modes are those associated with failure of the composite at the fastener hole. Unacceptable failure modes include those associated with the fastener (such as head, shank or thread failure) or failure of the composite away from the fastener hole.

5. Significance and Use

5.1 This test method is designed to produce fastener pull-through resistance data for structural design allowables, research and development. The procedures may be used to assess pull-through resistance for a variety of composite laminate thicknesses, fastener diameters, and fastener head styles. However, the flexibility of test parameters allowed by the variants makes meaningful comparison between datasets difficult if the datasets were not generated using identical test parameters.

5.2 Early composite pull-through tests using fasteners common to metal structures led to premature joint failures, and resulted in the development of fasteners specific for composite applications. These fasteners have larger heads and tails to reduce through-thickness compression stresses on the composite laminate.

5.3 General factors that influence the mechanical response of composite laminates and should therefore be reported include the following: material, methods of material preparation and lay-up, specimen stacking sequence, specimen preparation, specimen conditioning, environment of testing, specimen alignment, speed of testing, time at temperature, void content, and volume percent reinforcement.

5.4 Specific factors that influence the pull-through resistance of composite laminates and should therefore be reported include the following: hole diameter, fastener diameter, fastener head diameter, loading bar spacing to fastener hole diameter ratio (Procedure A), clearance hole diameter to fastener hole diameter ratio (Procedure B), diameter to thickness ratio, fastener torque, fastener or pin material, fastener or pin clearance, countersink angle and depth of countersink, type of grommet (if used), and type of support fixture. Fastener pull-through resistance properties which may be determined from this test method include initial sub-critical failure force/displacement, failure force, maximum force, and rupture displacement.

6. Interferences

6.1 *Material and Specimen Preparation*—Poor material fabrication practices, lack of control of fiber alignment, and damage induced by improper specimen machining are known causes of high material data scatter in composites in general. Important aspects of specimen preparation that contribute to data scatter include thickness variation, out-of-plane curvature, surface roughness, and failure to meet the dimensional tolerances specified in 8.2.2.

6.2 *Hole Preparation*—Because of the dominating presence of the filled hole, results from this test method are relatively insensitive to parameters that would be of concern in an unnotched tensile, compressive or flexural property test. However, since the filled hole dominates the strength, consistent preparation of the hole, without damage to the laminate, is important to meaningful results. Damage caused by hole preparation will affect strength results and can reduce the calculated strength.

6.3 *Fastener Head Style and Countersink*—Results are affected by the head style of the fastener utilized. In general, specimens

containing protruding head fasteners exhibit the highest pull-through resistance forces, followed by (in order of decreasing pull-through resistance forces) 100° tension head fasteners, 100° shear head fasteners, and 130° shear head fasteners. Results may also be affected by the ratio of countersunk (flush) head depth to thickness; the preferred ratio is the range from 0.0 to 0.7 unless the experiment is investigating the influence of this ratio.

6.4 *Fastener-Hole Clearance*—Results are affected by the clearance arising from the difference between hole and fastener diameters. Excess clearance can change the observed specimen behavior by promoting the onset of sub-critical failures, due to a decrease in the effective area of the composite which reacts the pull-through load. Damage due to insufficient clearance during fastener installation will affect strength results. For these reasons, both the hole and fastener diameters must be accurately measured and recorded. A typical aerospace tolerance on fastener-hole clearance is +75/-0 μm [+0.003/-0.000 in.] for structural fastener holes.

6.5 *Countersink Flushness*—Countersink flushness (depth or protrusion of the fastener head in a countersunk hole) will affect strength results and may affect the observed failure mode. Countersunk head fasteners shall be installed within $\pm 0.01 \pm 0.1$ mm [± 0.005 in.] from the composite surface, unless otherwise specified.

6.6 *Thickness*—Results are affected by the thickness of the specimen and the ratio of hole diameter to thickness. Fastener pull-through resistance is typically proportional to the thickness of the specimen. The preferred ratio of hole diameter to thickness is the range from 1.5 to 3.0 unless the experiment is investigating the influence of this ratio. Additionally, for both procedures the composite plate(s) must have sufficient thickness, flexural stiffness and flexural strength to transmit the fixture loading without excessive plate bending, flexural failure or bearing damage.

6.7 *Fastener Torque/Pre-load*—Results are affected by the installed fastener pre-load (clamping pressure), as this force must be overcome initially by the application of tensile loading to the fastener.

6.8 *Geometry*—Results are affected by the ratio of loading bar spacing to fastener hole diameter for Procedure A tests, and by the ratio of clearance hole diameter to fastener hole diameter for Procedure B tests. The ratio should be maintained as specified in Tables 1 and 2, unless the experiment is investigating the influence of this ratio.

6.9 *Test Fixture Characteristics*—The configuration of the test fixture can have a significant effect on test results. For Procedure A, friction between the composite plates and loading posts (resulting from plate flexure or hole misalignment) can cause force measurement errors and affect test results. For Procedure B, the configuration of the yoke, and its ability to minimize the applied moment to the test specimen, can affect test results. Additionally, for Procedure B the diameter of the clearance hole can affect the degree of bending in the composite plate.

6.10 *System Alignment*—Errors can result if the test fixture is not centered with respect to the loading axis of the test machine.

7. Apparatus

7.1 *Micrometers*—The micrometer(s) shall use a 4 to 6 mm [0.16 to 0.25 in.] nominal diameter ball-interface on irregular surfaces such as the bag-side of a laminate, and a flat anvil interface on machined edges or very smooth tooled surfaces. The accuracy of the instrument(s) shall be suitable for reading to within 1 % of the sample width and thickness. For typical specimen geometries, an instrument with an accuracy of ± 0.0025 mm [± 0.0001 in.] or better is desirable for thickness measurement, while an instrument with an accuracy of ± 0.025 mm [± 0.001 in.] or better is desirable for width and damage dimension measurement.

7.2 *Loading Fasteners or Pins*—The fastener type shall be specified as an initial test parameter and reported. Fastener grip lengths shall be selected to ensure that the threads do not contact the laminate after pin installation. The assembly torque (if applicable) shall be specified as an initial test parameter and reported. This value may be a measured torque or a specification torque for fasteners with lock-setting features. If washers are utilized, the washer type, number of washers, and washer location(s) shall be specified as initial test parameters and reported. The reuse of fasteners is not recommended due to potential differences in through-thickness clamp-up for a given torque level, caused by wear of the threads or deformation of the locking features.

7.3 *Torque Wrench*—If using a torqued fastener, a torque wrench used to tighten the fastener shall be capable of determining the applied torque to within ± 10 % of the desired value.

7.4 Support Fixture:

7.4.1 *Procedure A*—The test fixture for Procedure A, shown in Fig. 1, consists of two symmetric components, each of which consists of a base and four cylindrical supports, evenly spaced around the circumference of the base. When the composite plates are assembled within the fixture, the application of compressive force to the fixture imparts a compressive loading to the plates and tensile loading to the fastener.

TABLE 1 Recommended Minimum Thicknesses for Carbon Fiber-Reinforced Composite Pull-Through Test Plates, Procedures A and B

Shank Diameter, mm [in.]	Minimum Specimen Thickness, mm [in.]			
	Protruding Head Fasteners	100° Countersunk Tension Head Fasteners	100° Countersunk Shear Head Fasteners	100° Csk. Reduced Shear & 130° Csk. Head Fasteners
4.0 [0.156]	1.4 [0.055]	2.5 [0.100]	2.0 [0.080]	1.4 [0.055]
5.0 [0.190]	1.5 [0.060]	3.0 [0.120]	2.5 [0.100]	1.5 [0.060]
6.0 [0.250]	2.0 [0.080]	3.8 [0.150]	3.5 [0.140]	2.0 [0.080]
8.0 [0.313]	2.8 [0.110]	4.9 [0.195]	3.9 [0.155]	2.8 [0.110]
10.0 [0.375]	3.3 [0.130]	5.8 [0.230]	4.9 [0.195]	3.3 [0.130]

TABLE 2 Recommended Minimum Specimen Length/Width and Fixture Dimensions for Procedure B, Carbon Fiber-Reinforced Composites

Shank Diameter, mm [in.]	Min Specimen Length/Width (dimension "A"), mm [in.]	Fastener Position (dimension "B"), mm [in.]	Clearance Hole Diameter (dimension "C _B "), mm [in.]
4.0 [0.156]	68 [2.56]	34 [1.28]	34.0 [1.31]
5.0 [0.190]	72 [2.75]	36 [1.38]	38.0 [1.50]
6.0 [0.250]	84 [3.25]	42 [1.63]	50.0 [2.00]
8.0 [0.313]	96 [3.75]	48 [1.88]	63.0 [2.50]
10.0 [0.375]	108 [4.25]	54 [2.13]	75.0 [3.00]

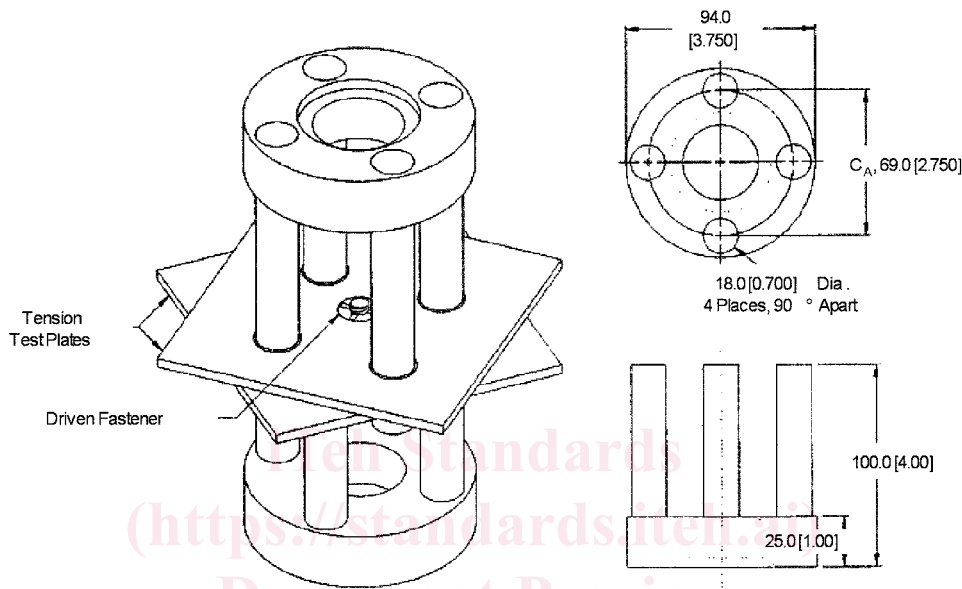

NOTE 1—All dimensions in millimetres [inches] unless otherwise specified.
 NOTE 2—Dimensional tolerances are linear ± 0.5 mm [± 0.02 in.], angular ± 0.5 degrees.
 NOTE 3—Break all edges.

FIG. 1 Fastener Pull-Through Test Fixture, Procedure A

7.4.2 *Procedure B*—The test fixture for Procedure B, shown in Fig. 2, consists of a rigid base plate, a channel section with a clearance hole, fasteners to secure the channel section to the base, and a loading yoke. When the composite specimen is placed within the fixture, the application of tensile force to the loading yoke imparts a compressive loading to the specimen and tensile loading to the fastener.

7.4.3 *Support Fixture Details*—The support fixture shall be constructed of sufficient stiffness and precision as to satisfy the loading uniformity requirements of this test method. The following general notes apply to these figures:

7.4.3.1 Machine surfaces to a 3.2 [125] rms surface finish unless otherwise specified.

7.4.3.2 Break all edges.

7.4.3.3 The test fixture shall be made of steel. It may be made of low carbon steel for ambient temperature testing. For non-ambient environmental conditions, the recommended fixture material is a nonheat-treated ferritic or precipitation hardened stainless steel (heat treatment for improved durability is acceptable but not required).

NOTE 2—Experience has shown that fixtures may be damaged due to handling in use, thus periodic re-inspection of the fixture dimensions and tolerances is important.

7.5 *Testing Machine*—The testing machine shall be in conformance with Practices E4, and shall satisfy the following requirements:

7.5.1 *Testing Machine Configuration*—The testing machine shall have both an essentially stationary head and a movable head. A short loading train and flat end-loading platens or grips shall be used.

7.5.2 *Flat Platens, Procedure A*—The test machine shall be mounted with well-aligned, fixed (as opposed to spherical seat) flat platens (58 HRC minimum as specified in Test Methods E18). The platen surfaces shall be parallel within 0.025 mm [0.001 in.] across the test fixture diameter (94 mm [3.75 in.]). If the platens are not sufficiently hardened, or simply to protect the platen surfaces, a hardened plate (with parallel surfaces) can be inserted between each end of the fixture and the corresponding platen. The lower platen should be marked to help center the test fixture between the platens.

7.5.3 *Grips, Procedure B*—Each head of the testing machine shall be capable of holding one end of the test assembly so that

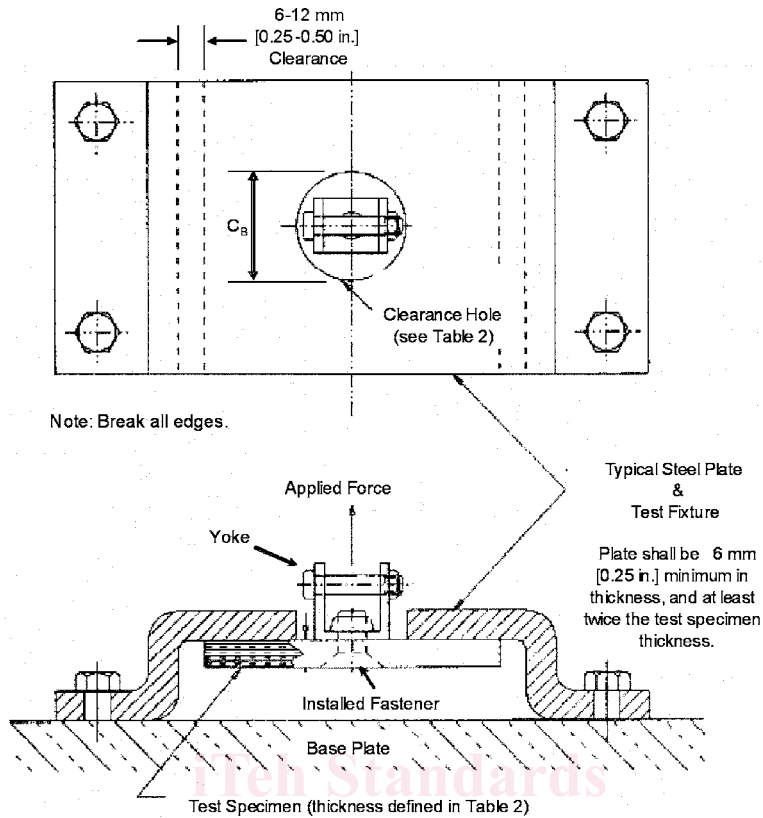

FIG. 2 Fastener Pull-Through Test Fixture, Procedure B

the direction of force applied to the specimen is coincident with the longitudinal axis of the fastener. The upper grip shall hold a connection to the test fixture yoke; the lower grip shall hold a connection to the test fixture base. If utilized, hydraulic wedge grips shall apply sufficient lateral pressure to prevent slippage between the grip face and the fixture attachment.

7.5.4 *Drive Mechanism*—The testing machine drive mechanism shall be capable of imparting to the movable head a controlled velocity with respect to the stationary head. The velocity of the movable head shall be capable of being regulated as specified in 11.3.

7.5.5 *Force Indicator*—The testing machine force-sensing device shall be capable of indicating the total force being carried by the test specimen. This device shall be essentially free from inertia-lag at the specified rate of testing and shall indicate the force with an accuracy over the force range(s) of interest of within $\pm 1\%$ of the indicated value.

7.5.6 *Crosshead Displacement Indicator*—The testing machine shall be capable of monitoring and recording the crosshead displacement (stroke) with a precision of at least $\pm 1\%$. If machine compliance is significant, it is acceptable to measure the displacement of the movable head using a LVDT or similar device with $\pm 1\%$ precision on displacement.

7.6 *Conditioning Chamber*—When conditioning materials at non-laboratory environments, a temperature-/vapor-level controlled environmental conditioning chamber is required that shall be capable of maintaining the required temperature to within $\pm 3^\circ\text{C}$ [$\pm 5^\circ\text{F}$] and the required relative humidity level to within $\pm 3\%$. Chamber conditions shall be monitored either on an automated continuous basis or on a manual basis at regular intervals.

7.7 *Environmental Test Chamber*—An environmental test chamber is required for test environments other than ambient testing laboratory conditions. This chamber shall be capable of maintaining the test specimen and fixture at the required test environment during the mechanical test. The test temperature shall be maintained within $\pm 3^\circ\text{C}$ [$\pm 5^\circ\text{F}$] of the required temperature, and the relative humidity level shall be maintained to within $\pm 3\%$ of the required humidity level.

7.8 *Data Acquisition Equipment*—Equipment capable of recording force and crosshead displacement data is required.

8. Sampling and Test Specimens

8.1 *Sampling*—Test at least five specimens per test condition unless valid results can be gained through the use of fewer specimens, as in the case of a designed experiment. For statistically significant data the procedures outlined in Practice E122 should be consulted. The method of sampling shall be reported.

8.2 Geometry:

8.2.1 *Stacking Sequence*—The standard tape and fabric laminates shall have multidirectional fiber orientations (fibers oriented in a minimum of three directions for tape laminates, and a minimum of two ply orientations for fabric laminates), and balanced and symmetric stacking sequences. Minimum thicknesses for carbon-fiber reinforced composites are defined in Table 1 for