

---

---

**Road vehicles — Media Oriented  
Systems Transport (MOST) —**

**Part 9:  
150-Mbit/s optical physical layer  
conformance test plan**

**iTeh STANDARD PREVIEW**  
*Véhicules routiers — Système de transport axé sur les médias —  
Partie 9: Plan d'essais de conformité de la couche optique physique à  
150-Mbit/s*  
(standards.iteh.ai)

[ISO 21806-9:2020](https://standards.iteh.ai/catalog/standards/sist/19624c0e-4e61-4888-90b2-ac8145965041/iso-21806-9-2020)

[https://standards.iteh.ai/catalog/standards/sist/19624c0e-4e61-4888-90b2-  
ac8145965041/iso-21806-9-2020](https://standards.iteh.ai/catalog/standards/sist/19624c0e-4e61-4888-90b2-ac8145965041/iso-21806-9-2020)



## iTeh STANDARD PREVIEW (standards.iteh.ai)

ISO 21806-9:2020

<https://standards.iteh.ai/catalog/standards/sist/19624c0e-4e61-4888-90b2-ac8145965041/iso-21806-9-2020>



### **COPYRIGHT PROTECTED DOCUMENT**

© ISO 2020

All rights reserved. Unless otherwise specified, or required in the context of its implementation, no part of this publication may be reproduced or utilized otherwise in any form or by any means, electronic or mechanical, including photocopying, or posting on the internet or an intranet, without prior written permission. Permission can be requested from either ISO at the address below or ISO's member body in the country of the requester.

ISO copyright office  
CP 401 • Ch. de Blandonnet 8  
CH-1214 Vernier, Geneva  
Phone: +41 22 749 01 11  
Email: [copyright@iso.org](mailto:copyright@iso.org)  
Website: [www.iso.org](http://www.iso.org)

Published in Switzerland

# Contents

	Page
Foreword .....	v
Introduction .....	vi
<b>1 Scope</b> .....	<b>1</b>
<b>2 Normative references</b> .....	<b>1</b>
<b>3 Terms and definitions</b> .....	<b>1</b>
<b>4 Symbols and abbreviated terms</b> .....	<b>2</b>
4.1 Symbols .....	2
4.2 Abbreviated terms .....	2
<b>5 Conventions</b> .....	<b>3</b>
<b>6 Operating conditions and measurement tools, requested accuracy</b> .....	<b>3</b>
6.1 Operating conditions .....	3
6.2 Apparatus — Measurement tools, requested accuracy .....	3
<b>7 Electrical characteristics</b> .....	<b>5</b>
7.1 Test according to LVDS .....	5
7.2 Test according to LVTTTL .....	5
<b>8 Optical characteristics</b> .....	<b>5</b>
8.1 Measurement of optical output power at SP2 .....	5
8.2 Measurement of optical input power at SP3 .....	6
8.3 Measurement of pigtail fibre attenuation .....	7
8.3.1 General .....	7
8.3.2 Practical considerations .....	9
8.4 Spectral parameters at SP2 .....	11
8.5 $b_0/b_1$ detection at SP2 .....	11
8.6 Extinction ratio at SP2 .....	13
8.7 Optical overshoot and undershoot at SP2 .....	13
8.7.1 General .....	13
8.7.2 Overshoot measurement example .....	14
8.7.3 Undershoot (2 UI) measurement example .....	16
8.7.4 Undershoot (4UI) measurement example .....	16
8.8 Transition times at SP2 .....	17
8.9 Stimulus creation for SP3 .....	18
<b>9 Measurement of phase variation</b> .....	<b>19</b>
9.1 General .....	19
9.2 Measuring alignment jitter .....	21
9.3 Measuring transferred jitter .....	23
9.4 Test set-ups .....	25
9.4.1 Relevant eye mask for MOST components .....	25
9.4.2 SP4 jitter measurement (AJ and TJ) .....	26
9.4.3 SP2 jitter measurement (AJ and TJ) .....	27
9.5 Crosstalk .....	28
9.5.1 General .....	28
9.5.2 Measurement set-up .....	28
9.5.3 Procedure .....	29
<b>10 Power-on and power-off</b> .....	<b>29</b>
10.1 General .....	29
10.2 Measuring EOC parameters .....	30
10.2.1 Measuring EOC parameters — Test set-up .....	30
10.2.2 Measuring EOC parameters — Signal charts .....	31
10.2.3 Measuring EOC parameters — Test sequences .....	33
10.3 Measuring OEC parameters .....	37

10.3.1	Measuring OEC parameters — Test set-up .....	37
10.3.2	Measuring OEC parameters — Signal charts.....	38
10.3.3	Measuring OEC parameters — Test sequences.....	39
<b>11</b>	<b>Detecting bit rate (frequency reference).....</b>	<b>43</b>
<b>12</b>	<b>System performance.....</b>	<b>43</b>
12.1	General.....	43
12.2	SP4 receiver tolerance.....	43
12.3	TimingMaster delay tolerance.....	44
<b>13</b>	<b>Conformance tests of 150-Mbit/s optical physical layer.....</b>	<b>47</b>
13.1	Location of interfaces.....	47
13.2	Control signals.....	48
13.3	Limited access to specification points.....	49
13.4	Parameter overview.....	49
<b>14</b>	<b>Physical layer verification for MOST components, MOST modules, and MOST devices.....</b>	<b>51</b>
14.1	FOT.....	51
14.2	Pigtail.....	52
14.3	MOST device.....	52
14.4	Development tool.....	52
<b>15</b>	<b>Full physical layer conformance.....</b>	<b>52</b>
15.1	Overview.....	52
15.2	Consideration of FOT.....	52
15.3	Consideration of pigtail.....	52
15.4	Consideration of connector interfaces.....	52
15.5	Generating test signals for the IUT.....	53
15.5.1	General information.....	53
15.5.2	Test set-up for jitter measurement.....	53
<b>16</b>	<b>Limited physical layer conformance.....</b>	<b>53</b>
16.1	Overview.....	53
16.2	Generating test signals for the IUT input section SP3.....	55
16.3	Analysis of test results.....	56
16.4	Test flow overview.....	56
16.5	Measurement of SP3 input signal of the IUT.....	57
16.6	Measurement of SP2 output signal of the IUT.....	58
16.7	Functional testing of wake-up and shutdown.....	58
<b>17</b>	<b>Direct physical measuring accuracy.....</b>	<b>59</b>
<b>18</b>	<b>General remarks.....</b>	<b>61</b>
18.1	Definition of family.....	61
18.2	Supplier guideline for product changes.....	61
18.3	Dependency of the network frame rate.....	62
<b>Annex A (informative) Measuring optical signals at SP2 using averaging.....</b>		<b>63</b>
<b>Annex B (normative) SNR requirements for test equipment.....</b>		<b>64</b>
<b>Annex C (informative) Limited physical layer conformance for development tools.....</b>		<b>67</b>
<b>Bibliography.....</b>		<b>68</b>

## Foreword

ISO (the International Organization for Standardization) is a worldwide federation of national standards bodies (ISO member bodies). The work of preparing International Standards is normally carried out through ISO technical committees. Each member body interested in a subject for which a technical committee has been established has the right to be represented on that committee. International organizations, governmental and non-governmental, in liaison with ISO, also take part in the work. ISO collaborates closely with the International Electrotechnical Commission (IEC) on all matters of electrotechnical standardization.

The procedures used to develop this document and those intended for its further maintenance are described in the ISO/IEC Directives, Part 1. In particular, the different approval criteria needed for the different types of ISO documents should be noted. This document was drafted in accordance with the editorial rules of the ISO/IEC Directives, Part 2 (see [www.iso.org/directives](http://www.iso.org/directives)).

Attention is drawn to the possibility that some of the elements of this document may be the subject of patent rights. ISO shall not be held responsible for identifying any or all such patent rights. Details of any patent rights identified during the development of the document will be in the Introduction and/or on the ISO list of patent declarations received (see [www.iso.org/patents](http://www.iso.org/patents)).

Any trade name used in this document is information given for the convenience of users and does not constitute an endorsement.

For an explanation of the voluntary nature of standards, the meaning of ISO specific terms and expressions related to conformity assessment, as well as information about ISO's adherence to the World Trade Organization (WTO) principles in the Technical Barriers to Trade (TBT), see [www.iso.org/iso/foreword.html](http://www.iso.org/iso/foreword.html) (standards.iteh.ai)

This document was prepared by Technical Committee ISO/TC 22, *Road vehicles*, Subcommittee SC 31, *Data communication*.

A list of all parts in the ISO 21806 series can be found on the ISO website.  
<https://standards.iteh.ai/catalog/standards/sist/19624c0e-4e61-4888-90b2-145965914180/iso-21806-9:2020>

Any feedback or questions on this document should be directed to the user's national standards body. A complete listing of these bodies can be found at [www.iso.org/members.html](http://www.iso.org/members.html).

## Introduction

The Media Oriented Systems Transport (MOST) communication technology was initially developed at the end of the 1990s in order to support complex audio applications in cars. The MOST Cooperation was founded in 1998 with the goal to develop and enable the technology for the automotive industry. Today, MOST<sup>1)</sup> enables the transport of high quality of service (QoS) audio and video together with packet data and real-time control to support modern automotive multimedia and similar applications. MOST is a function-oriented communication technology to network a variety of multimedia devices comprising one or more MOST nodes.

Figure 1 shows a MOST network example.

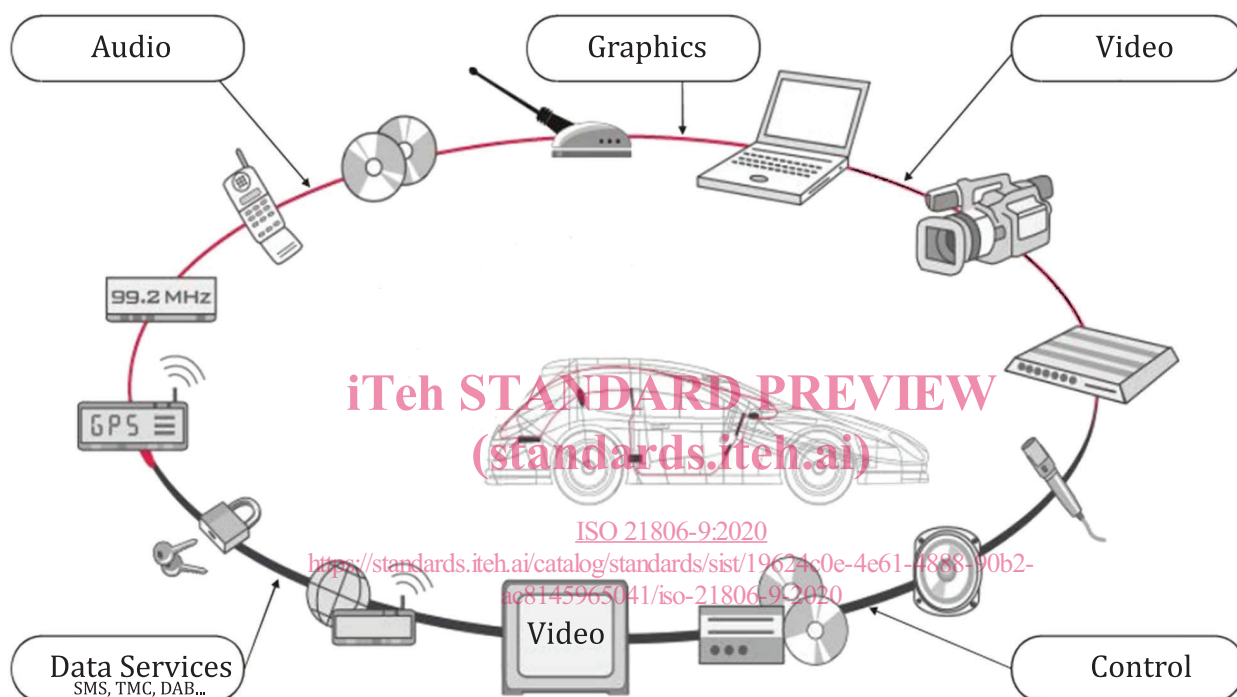

Figure 1 — MOST network example

The MOST communication technology provides

- synchronous and isochronous streaming,
- small overhead for administrative communication control,
- a functional and hierarchical system model,
- API standardization through a function block (FBlock) framework,
- free partitioning of functionality to real devices,
- service discovery and notification, and
- flexibly scalable automotive-ready Ethernet communication according to ISO/IEC/IEEE 8802-3<sup>[3]</sup>.

MOST is a synchronous time-division-multiplexing (TDM) network that transports different data types on separate channels at low latency. MOST supports different bit rates and physical layers. The network clock is provided with a continuous data signal.

1) MOST® is the registered trademark of Microchip Technology Inc. This information is given for the convenience of users of this document and does not constitute an endorsement by ISO.

Within the synchronous base data signal, the content of multiple streaming connections and control data is transported. For streaming data connections, bandwidth is reserved to avoid interruptions, collisions, or delays in the transport of the data stream.

MOST specifies mechanisms for sending anisochronous, packet-based data in addition to control data and streaming data. The transmission of packet-based data is separated from the transmission of control data and streaming data. None of them interfere with each other.

A MOST network consists of devices that are connected to one common control channel and packet channel.

In summary, MOST is a network that has mechanisms to transport the various signals and data streams that occur in multimedia and infotainment systems.

The ISO standards maintenance portal (<https://standards.iso.org/iso/>) provides references to MOST specifications implemented in today's road vehicles because easy access via hyperlinks to these specifications is necessary. It references documents that are normative or informative for the MOST versions 4V0, 3V1, 3V0, and 2V5.

The ISO 21806 series has been established in order to specify requirements and recommendations for implementing the MOST communication technology into multimedia devices and to provide conformance test plans for implementing related test tools and test procedures.

To achieve this, the ISO 21806 series is based on the open systems interconnection (OSI) basic reference model in accordance with ISO/IEC 7498-1<sup>[1]</sup> and ISO/IEC 10731<sup>[2]</sup>, which structures communication systems into seven layers as shown in [Figure 2](#). Stream transmission applications use a direct stream data interface (transparent) to the data link layer.

ITd STANDARD PREVIEW  
(standards.iteh.ai)

[ISO 21806-9:2020](https://standards.iteh.ai/catalog/standards/sist/19624c0e-4e61-4888-90b2-ac8145965041/iso-21806-9-2020)

<https://standards.iteh.ai/catalog/standards/sist/19624c0e-4e61-4888-90b2-ac8145965041/iso-21806-9-2020>

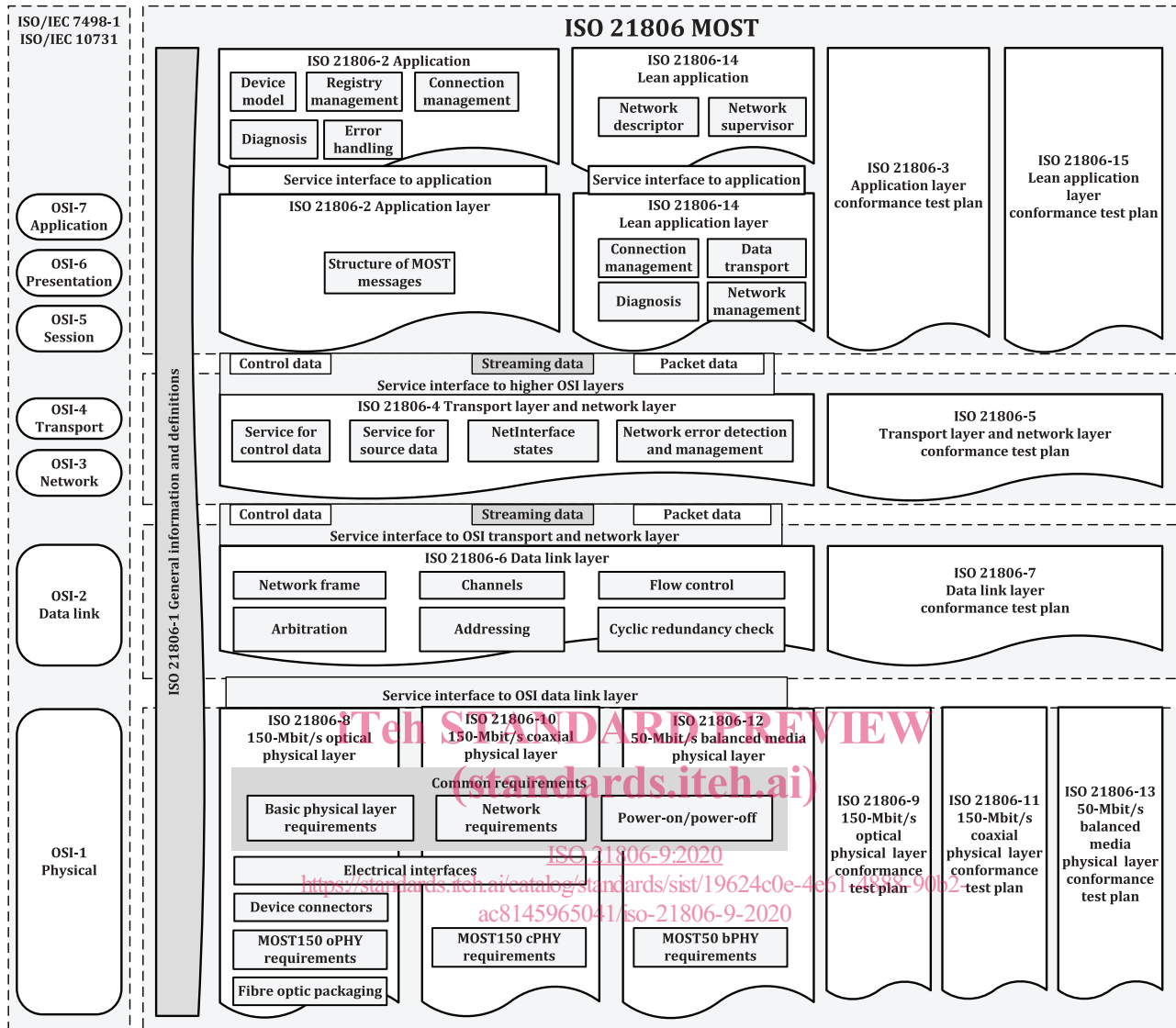

Figure 2 — The ISO 21806 series reference according to the OSI model

The International Organization for Standardization (ISO) draws attention to the fact that it is claimed that compliance with this document may involve the use of a patent.

ISO takes no position concerning the evidence, validity and scope of this patent right.

The holder of this patent right has assured ISO that he/she is willing to negotiate licences under reasonable and non-discriminatory terms and conditions with applicants throughout the world. In this respect, the statement of the holder of this patent right is registered with ISO. Information may be obtained from the patent database available at [www.iso.org/patents](http://www.iso.org/patents).

Attention is drawn to the possibility that some of the elements of this document may be the subject of patent rights other than those in the patent database. ISO shall not be held responsible for identifying any or all such patent rights.



# Road vehicles — Media Oriented Systems Transport (MOST) —

## Part 9: 150-Mbit/s optical physical layer conformance test plan

### 1 Scope

This document specifies the conformance test plan for the 150-Mbit/s optical physical layer for MOST (MOST150 oPHY), a synchronous time-division-multiplexing network.

This document specifies the basic conformance test measurement methods, relevant for verifying compatibility of networks, nodes, and MOST components with the requirements specified in ISO 21806-8.

### 2 Normative references

The following documents are referred to in the text in such a way that some or all of their content constitutes requirements of this document. For dated references, only the edition cited applies. For undated references, the latest edition of the referenced document (including any amendments) applies.

ISO 21806-1, *Road vehicles — Media Oriented Systems Transport (MOST) — Part 1: General information and definitions*

ISO 21806-9:2020

ISO 21806-8:2020, *Road vehicles — Media Oriented Systems Transport (MOST) — Part 8: 150-Mbit/s optical physical layer*

IEC 60793-1-40, *Optical fibres — Part 1-40: Measurement methods and test procedures — Attenuation*

IEC 61280-1-3, *Fibre optic communication subsystem test procedures — Part 1-3: General communication subsystems — Central wavelength and spectral width measurement, Method B*

IEC 61280-2-2, *Fibre optic communication subsystem test procedures — Part 2-2: Digital systems — Optical eye pattern, waveform and extinction ratio measurement*

IEC 61300-3-4, *Fibre optic interconnecting devices and passive components — Basic test and measurement procedures — Part 3-4: Examinations and measurements — Attenuation*

JEDEC No. JESD8C.01<sup>2)</sup>, *Interface Standard for Nominal 3 V/3.3 V Supply Digital Integrated Circuits*

TIA/EIA-644-A<sup>3)</sup>, *Electrical Characteristics of Low-Voltage Differential Signaling (LVDS) Interface Circuits*

### 3 Terms and definitions

For the purposes of this document, the terms and definitions given in ISO 21806-1, ISO 21806-8, and the following apply.

ISO and IEC maintain terminological databases for use in standardization at the following addresses:

— ISO Online browsing platform: available at <https://www.iso.org/obp>

2) Available at <https://www.jedec.org/>.

3) Available at <https://www.tiaonline.org/standards/>.

— IEC Electropedia: available at <http://www.electropedia.org/>

**3.1 intersymbol interference**  
disturbance due to the overflowing into the signal element representing a wanted digit of signal elements representing preceding or following digits

[SOURCE: IEC Electropedia 702-08-33]

## 4 Symbols and abbreviated terms

### 4.1 Symbols

---	empty cell/undefined
$t_{OSLE}$	time of optical signal level detection end
$t_{OSLS}$	time of optical signal level detection start
$\rho_{Fs}$	frame rate
$\rho_{BR}$	bit rate

### 4.2 Abbreviated terms

For the purposes of this document, the abbreviated terms given in ISO 21806-1, ISO 21806-8, and the following apply.

AC	alternate current	<a href="https://standards.iteh.ai/catalog/standards/sist/19624c0e-4e61-4888-90b2-ac8145965041/iso-21806-9-2020">ISO 21806-9:2020</a>
AJ	alignment jitter	<a href="https://standards.iteh.ai/catalog/standards/sist/19624c0e-4e61-4888-90b2-ac8145965041/iso-21806-9-2020">https://standards.iteh.ai/catalog/standards/sist/19624c0e-4e61-4888-90b2-ac8145965041/iso-21806-9-2020</a>
AWG	arbitrary waveform generator	
BW	bandwidth	
DC	direct current	
DCD	duty cycle distortion	
DSO	digital sampling oscilloscope	
IUT	implementation under test	
EMD	equilibrium mode power distribution	
EOC	electrical optical converter	
FOT	fibre optic transceiver	
MNC	MOST network controller	
NA	numerical aperture	
OEC	optical electrical converter	
PG	pattern generator	
PHYSTT	physical layer stress test tool	

PLL	phase lock loop
POF	plastic optical fibre
RMS	root mean square
SDA	serial data analyser
SMD	surface mount device
SNR	signal-to-noise ratio
SP	Specification Point
THM	through hole mount
TJ	transferred jitter
UI	unit interval
VCM	common mode voltage

## 5 Conventions

This document is based on OSI service conventions as specified in ISO/IEC 10731[2].

## 6 Operating conditions and measurement tools, requested accuracy

### 6.1 Operating conditions

ISO 21806-9:2020

<https://standards.iteh.ai/catalog/standards/sist/19624c0e-4e61-4888-90b2->

Temperature range for MOST components:  $T_A = -40\text{ °C}$  to  $+95\text{ °C}$  according to ISO 21806-8:2020, 11.4.

Voltage range for MOST components:  $V_{CC} = 3,135\text{ V}$  to  $3,465\text{ V}$  according to ISO 21806-8:2020, Clause 10.

NOTE There are functional requirements for the EOC within an extended voltage supply range according to ISO 21806-8.

### 6.2 Apparatus — Measurement tools, requested accuracy

The following list provides state-of-the-art tools.

#### 6.2.1 Oscilloscope

- digital sampling oscilloscope;
- sampling rate  $\geq 10$  gigasample/s;
- bandwidth  $\geq 1,5$  GHz;
- sampling memory  $\geq 10$  megasample;
- active probe (single-ended, differential).

#### 6.2.2 High-speed OEC

- bandwidth  $\geq 250$  MHz (DC-coupled) for  $b_0/b_1$  measurement to calculate extinction ratio  $r_{e2}$ ;
- bandwidth  $\geq 750$  MHz (DC- or AC-coupled) for all other measurements;

- performance recommendation:
  - response flatness: 1 dB (constant gain over bandwidth; linear transfer function over the optical input range);
  - low DC offset error (see 8.5).

### 6.2.3 High-speed EOC

- light source with a pulse shape representing a high-bandwidth emitter:
  - transition time  $t_r$  and  $t_f$  below 1 ns;
  - overshoot greater than 1,25 of normalized amplitude;
  - extinction ratio: 10 dB to 12 dB.
- light source with a pulse shape representing a low-bandwidth emitter:
  - transition time  $t_r$  and  $t_f$  between 1 ns and 0,5 UI;
  - overshoot: no overshoot;
  - extinction ratio: 10 dB to 12 dB.

### 6.2.4 Optical power meter

- accuracy: at least  $\pm 0,25$  dB;
- accuracy optical power meter and SP2 adaptor: at least  $\pm 0,5$  dB;
- wavelength: 650 nm;
- range: at least -60 dBm to 0 dBm;
- trigger input (for timing measurements).

ITeH STANDARD PREVIEW  
(standards.iteh.ai)

<https://standards.iteh.ai/catalog/standards/sist/19624c0e-4e61-4888-90b2-ac8145965041/iso-21806-9-2020>

### 6.2.5 Ampere meter

- accuracy  $\leq 2$   $\mu$ A;
- trigger input (for timing measurements).

### 6.2.6 Pattern generator for generating MOST150 oPHY stress pattern

- bandwidth 300 Mbit/s;
- trigger output (for timing measurements).

### 6.2.7 Optical attenuator

- attenuation up to 40 dB;
- preferably attenuation via grey filter, not via air gap.

### 6.2.8 Optical Y-coupler.

### 6.2.9 Optical spectrometer

- resolution  $\leq 1$  nm;

— spectral range at least 500 nm to 800 nm.

## 7 Electrical characteristics

### 7.1 Test according to LVDS

Testing of MOST devices or MOST components shall be performed according to the measurement methods and set-ups specified in TIA/EIA-644-A. Parameters and their respective limits are also derived from TIA/EIA-644-A, with the exception of common mode voltage ( $V_{CM}$ ) as specified in ISO 21806-8:2020, 12.1.

### 7.2 Test according to LVTTTL

Testing of MOST devices or MOST components shall be performed in accordance with JEDEC No. JESD8C.01.

## 8 Optical characteristics

### 8.1 Measurement of optical output power at SP2

Figure 3 shows the schematic of an optical power meter. This measurement adaptor allows the test of parameter  $P_{opt2}$  considering the power within a far field angle of  $30^\circ$  ( $NA = 0,5$ ) and a diameter of 1,0 mm.

The optical power at SP2 is transferred by a glass fibre with a numerical aperture of greater than 0,5, a core diameter of 1 000  $\mu\text{m}$ , and a typical length of 30 mm. An aperture between glass fibre and photo detector confines the transferred beam to the required numerical aperture of 0,5. The size of the aperture depends on the distance between glass fibre and the aperture (see Figure 4). The end face of the glass fibre shall be polished to avoid scattering and a conversion of the beam waist from SP2 to the end of the glass fibre. The glass fibre is mounted into a ferrule, which can be inserted into an SP2-contact of a MOST device for measuring the optical power at SP2 (MOST compatible ferrule, i.e. derived from connector drawing).

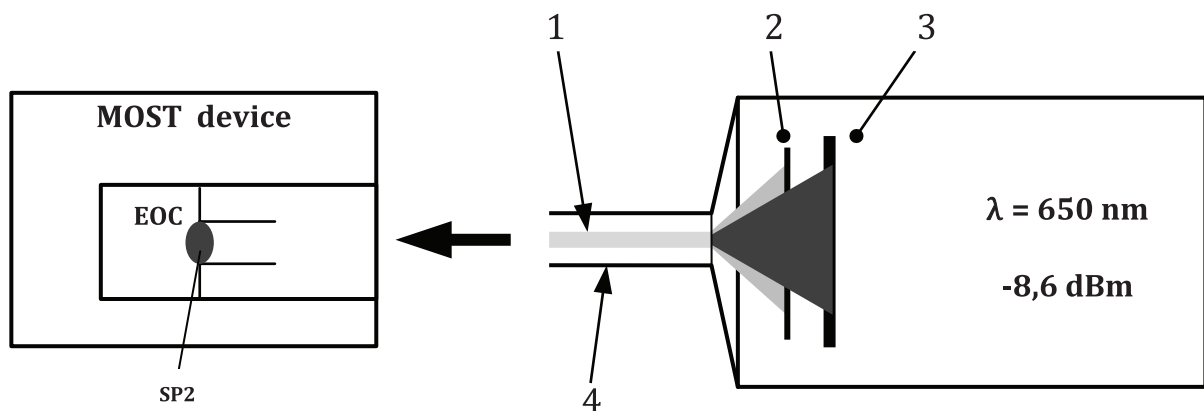

#### Key

- 1 glass fibre,  $D = 1 \text{ mm}$ ,  $NA \geq 0,5$
- 2  $NA = 0,5$
- 3 large area photo detector
- 4 MOST compatible ferrule

Figure 3 — Schematic of optical power meter

Figure 4 shows the calculation of aperture size  $d_B$ .

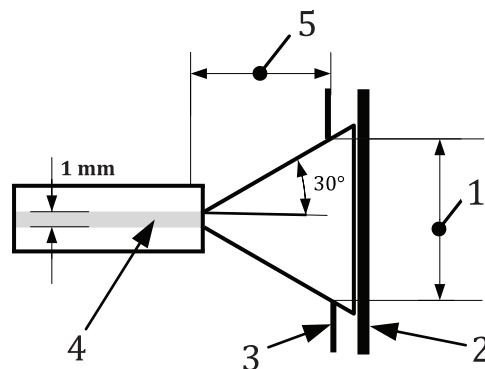

**Key**

- 1 aperture size  $d_B$ : see [Formula \(1\)](#)
- 2 photo detector
- 3 aperture
- 4 glass fibre
- 5 distance  $X$  between the glass fibre and the aperture

**Figure 4 — Calculation of aperture size  $d_B$**

**IMPORTANT — It should be ensured that the size of the photo detector is large enough to receive all the light after the aperture.**

$$d_B = c + 2 \times X \times \tan(30^\circ) \tag{1}$$

where

[ISO 21806-9:2020](https://standards.iteh.ai/catalog/standards/sist/19624c0e-4e61-4888-90b2-ac8145965041/iso-21806-9-2020)  
<https://standards.iteh.ai/catalog/standards/sist/19624c0e-4e61-4888-90b2-ac8145965041/iso-21806-9-2020>

- $d_B$  is the aperture size;
- $X$  is the distance between the glass fibre and the aperture;
- $c$  is the diameter: 1 mm.

**8.2 Measurement of optical input power at SP3**

The optical power measurement set-up is given in [Figure 5](#). This measurement allows the testing of the parameter  $P_{opt3}$  considering the power within a far field angle of  $30^\circ$  ( $NA = 0,5$ ) and a diameter of 1,0 mm.

[Figure 5](#) shows the optical power measurement set-up for SP3.

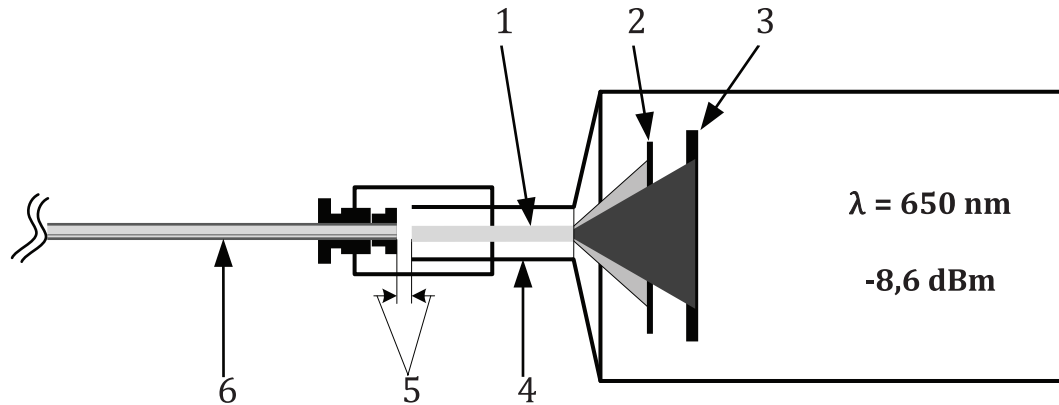

### Key

- 1 glass fibre,  $D = 1 \text{ mm}$ ,  $NA \geq 0,5$
- 2  $NA = 0,5$
- 3 large area photo detector
- 4 MOST ferrule
- 5  $50 \mu\text{m}$  to  $100 \mu\text{m}$ ; see connector interfaces in ISO 21806-8
- 6 1 mm POF cable harness

**Figure 5 — Optical power measurement set-up for SP3**

A glass fibre and an aperture transfer the measured optical power-on a large area photo detector. For description and the calculation base for the aperture see 8.1.

In ISO 21806-8,  $P_{\text{opt3}}$  is the value of the optical power, when the incoming signal passes the receiving contact end face.

Compared to the glass fibre used in the measurement set-up, the surface quality of a real SP3 contact might be worse. This might result in a lower input power than shown by the measurement. This small mismatch is covered by the specified connection loss. The axial offset shown in Figure 5 considers a requirement defined in the connector interface drawings (see ISO 21806-8).

## 8.3 Measurement of pigtail fibre attenuation

### 8.3.1 General

Attenuation of a pigtail fibre is measured using the insertion method, which shall be in accordance with IEC 61300-3-4. The measurement set-up consists of a light source, a mode mixer, which shall be in accordance with IEC 60793-1-40, and a launching fibre for generating the stimulus signal. For detection of optical power, a power meter is used. The connection between IUT and power meter is realized with a secondary launching fibre or an equivalent arrangement.

The measurement is performed in two steps. The first step consists of the measurement of the initial power level  $P_{\text{Initial}}$  (see Figure 6) while the second step provides the measurement of the power level with the connected pigtail fibre  $P_{\text{IUT}}$  (see Figure 7). Figure 6 shows the measurement of  $P_{\text{Initial}}$ .