



Designation: ~~D3796-90 (Reapproved 2004)~~ Designation: ~~D3796 - 09~~

## Standard Practice for Calibration of Type S Pitot Tubes<sup>1</sup>

This standard is issued under the fixed designation D3796; the number immediately following the designation indicates the year of original adoption or, in the case of revision, the year of last revision. A number in parentheses indicates the year of last reapproval. A superscript epsilon ( $\epsilon$ ) indicates an editorial change since the last revision or reapproval.

### 1. Scope

1.1 This practice covers the determination of Type S pitot tube coefficients in the gas velocity range from 305 to 1524 m/min or 5.08 to 25.4 m/s [~~1000(1000 to 5000 ft/min)~~ ft/min]. The method applies both to the calibration of isolated Type S pitot tubes (see 5.1), and pitobe assemblies.

1.2 This practice outlines procedures for obtaining Type S pitot tube coefficients by calibration at a single-velocity setting near the midpoint of the normal working range. Type S pitot coefficients obtained by this method will generally be valid to within  $\pm 3\%$  over the normal working range. If a more precise correlation between Type S pitot tube coefficient and velocity is desired, multivelocity calibration technique (Annex A1) ~~should be used~~.

~~1.3 This practice may be used for the calibration of thermal anemometers for gas velocities in excess of 3 m/s [10 ft/s].  
1.4) should be used. The calibration coefficients determined for the Type S pitot tube by this practice do not apply in field use when the flow is nonaxial to the face of the tube.~~

1.3 This practice may be used for the calibration of thermal anemometers for gas velocities in excess of 3 m/s (10 ft/s).

1.4 The values stated in SI units are to be regarded as standard.

1.5 This standard does not purport to address all of the safety concerns, if any, associated with its use. It is the responsibility of the user of this standard to establish appropriate safety and health practices and determine the applicability of regulatory limitations prior to use.

### 2. Referenced Document

2.1 *ASTM Standards*:<sup>2</sup>

D1356 *Terminology Relating to Sampling and Analysis of Atmospheres*

### 3. Terminology

3.1 For definitions of terms used in this test method, refer to Terminology D1356.

3.2 *Definitions*:

3.2.1 *isolated Type S pitot tube*—any Type S pitot tube that is calibrated or used alone (Fig. 1).

3.2.2 *normal working velocity range*—the range of gas velocities ordinarily encountered in industrial smokestacks and ducts: approximately 305 to 1524 m/min or 5.08 to 25.4 m/s [~~1000(1000 to 5000 ft/min)~~ ft/min].

3.2.3 *pitobe assembly*—any Type S pitot tube that is calibrated or used while attached to a conventional isokinetic source-sampling probe (designed in accordance with Martin (1)<sup>3</sup> or allowable modifications thereof; see also Fig. 7).

### 4. Summary of Practice

4.1 The coefficients of a given Type S pitot tube are determined from alternate differential pressure measurements, made first with a standard pitot tube, and then with the Type S pitot tube, at a predetermined point in a confined, flowing gas stream. The Type S pitot coefficient is equal to the product of the standard pitot tube coefficient,  $C_p$  (std), and the square root of the ratio of the differential pressures indicated by the standard and Type S pitot tubes.

### 5. Significance and Use

5.1 The Type S pitot tube (Fig. 1) is often used to measure the velocity of flowing gas streams in industrial smokestacks and ducts. Before a Type S pitot tube is used for this purpose, its coefficients must be determined by calibration against a standard pitot tube (2).

<sup>1</sup> This practice is under the jurisdiction of ASTM Committee D22 on Air Quality and is the direct responsibility of Subcommittee D22.01 on Quality Control. Current edition approved Oct. 1, 2004-2009. Published December 2004-October 2009. Originally approved in 1979. Last previous edition approved in 1998-2004 as D3796 - 90 (1998)-(2004). DOI: 10.1520/D3796-90R04.10.1520/D3796-09.

<sup>2</sup> For referenced ASTM standards, visit the ASTM website, www.astm.org, or contact ASTM Customer Service at service@astm.org. For *Annual Book of ASTM Standards* volume information, refer to the standard's Document Summary page on the ASTM website.

<sup>3</sup> The boldface numbers in parentheses refer to the list of references at the end of this practice.

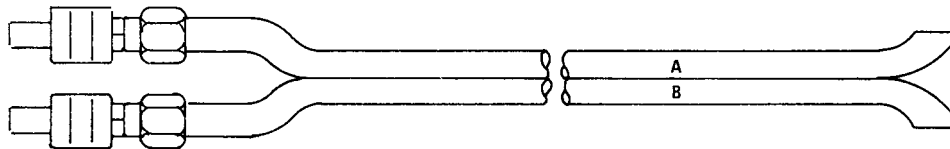

FIG. 1 Isolated Type-S Pitot Tube

## 6. Apparatus

6.1 *Flow System*—Calibration shall be done in a flow system designed in accordance with the criteria illustrated in Fig. 2 and described in 6.1.1 through 6.1.5.

6.1.1 The flowing gas stream shall be confined within a definite cross-sectional area; the cross section shall be preferably circular or rectangular (3). For circular cross sections, the minimum duct diameter shall be 305 mm {12 in.} (12 in.). For rectangular cross sections, the width shall be at least 254 mm {10 in.} (10 in.). Other regular cross-section geometries (for example, hexagonal or octagonal) are permissible, provided that they have cross-sectional areas of at least 645 cm<sup>2</sup> {100 in.<sup>2</sup>}.

6.1.2 It is recommended that the cross-sectional area of the flow-system duct be constant over a distance of 10 or more duct diameters. For rectangular cross sections, use an equivalent diameter, calculated as follows, to determine the number of duct diameters:

$$(1) \quad D_e = 2LW/(L + W)$$

where:

$D_e$  = equivalent diameter,

$L$  = length of cross section, and

$W$  = width of cross section.

For regular polygonal ducts, use an equivalent diameter, equal to the diameter of the inscribed circle, to determine the number of duct diameters.

6.1.3 To ensure the presence of stable, well-developed flow patterns at the calibration site (test section), it is recommended that the site be located at least 8 duct diameters (or equivalent diameters) downstream and 2 diameters upstream from the nearest flow disturbances. If the 8 and 2-diameter criteria cannot be met, the existence of stable, developed flow at the test site must be adequately demonstrated.

6.1.4 The flow-system fan shall have the capacity to generate a test-section velocity of about 909 m/min or 15.2 m/s {3000 ft/min} (3000 ft/min); this velocity should be constant with time. The fan can be located either upstream (Fig. 2) or downstream from the test-section.

6.1.5 Two entry ports, one each for the Type S and standard pitot tubes, shall be cut in the test section. The standard pitot tube entry port shall be located slightly downstream of the Type S port, so that the standard and Type S impact openings will lie in the same plane during calibration. To facilitate alignment of the pitot tubes during calibration, it is advisable that the test section be constructed of acrylic or similar transparent material.

6.2 *Standard Pitot Tube*, used to calibrate the Type S pitot tube. The standard pitot tube shall have a known coefficient, obtained preferably directly from the National Institute of Standards and Technology in Gaithersburg, MD. Alternatively, a modified ellipsoidal-nosed pitot static tube, designed as shown in Fig. 3 may be used (4). Note that the coefficient of the ellipsoidal-nosed tube is a function of the stem/static hole distance; therefore, Fig. 4 should be used as a guide for determining the precise coefficient value.

6.3 *Type S Pitot Tube*, (isolated pitot or pitobe assembly) either a commercially available model or constructed in accordance with Martin (1) or allowable modifications thereof.

6.4 *Differential Pressure Gage*—An inclined manometer, or equivalent device, shall be used to measure differential pressure.

The gage shall be capable of measuring  $\Delta P$  to within  $\pm 0.13$  mm water or 1.2 Pa [ $\pm 0.005$  ( $\pm 0.005$  in. water)–water].

6.5 *Pitot Lines*—Flexible lines, made of poly(vinyl chloride) (or similar material) shall be used to connect the standard and Type S pitot tubes to the differential-pressure gage.

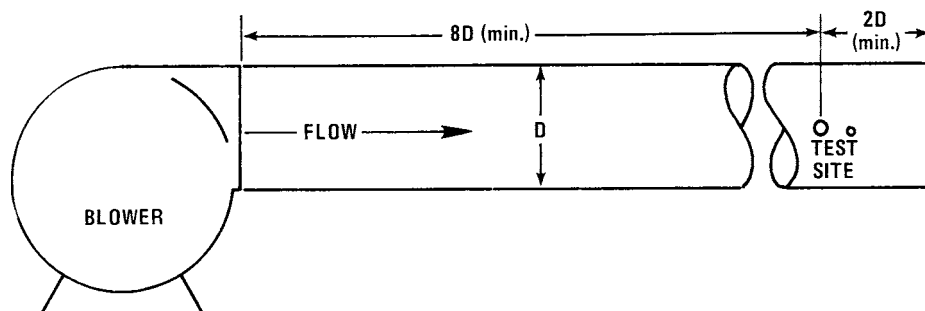

FIG. 2 Pitot Tube Calibration System

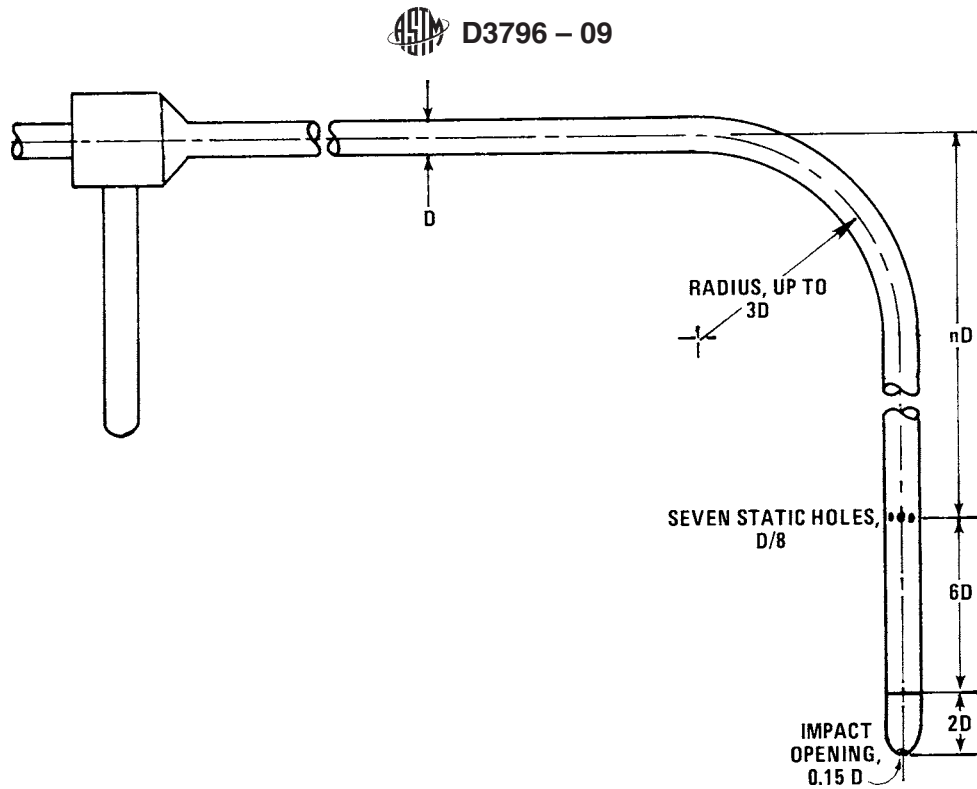

FIG. 3 Ellipsoidal Nosed Pitot-Static Tube

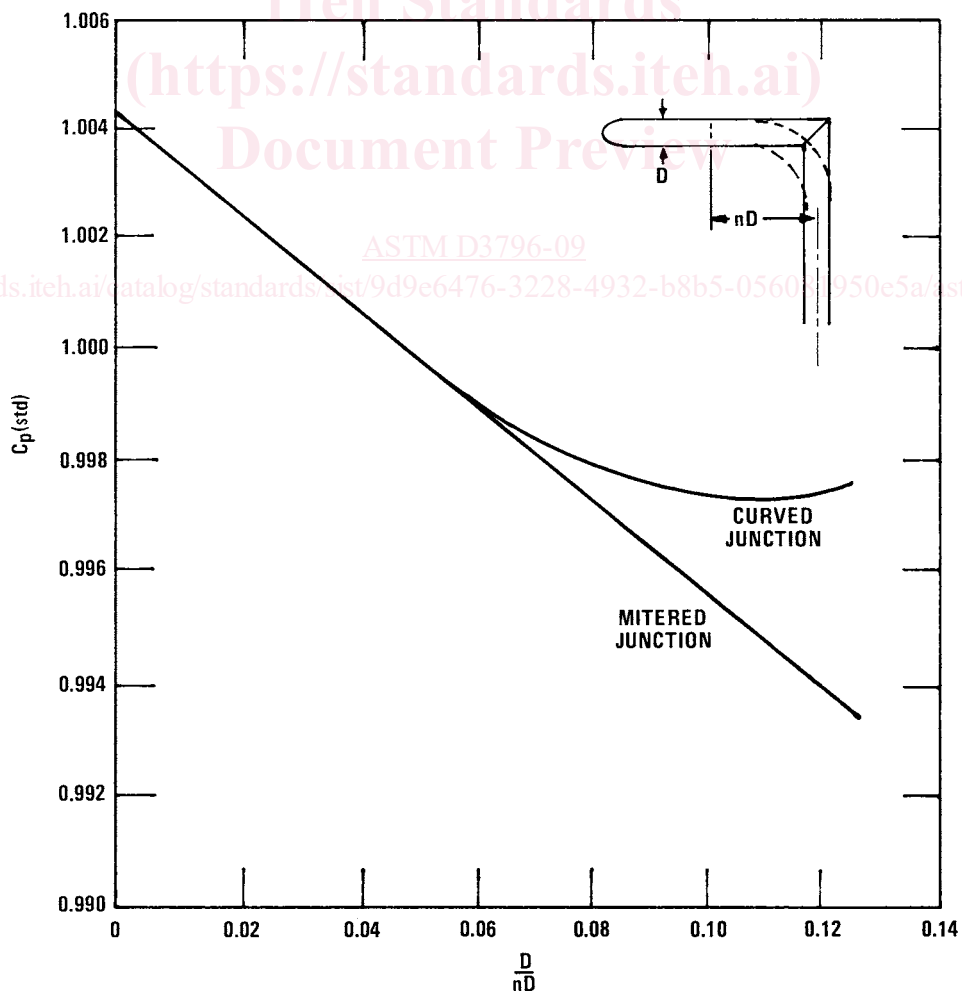

FIG. 4 Effect of Stem/Static Hole Distance on Basic Coefficient,  $C_p$  (std), of Standard Pitot-Static Tubes with Ellipsoidal Nose

**7. Procedure**

7.1 Assign a permanent identification number to the Type S pitot tube. Mark or engrave this number on the body of the tube. Mark one leg of the tube “A,” and the other, “B.”

7.2 Prepare the differential-pressure gage for use. If an inclined manometer is to be used, be sure that it is properly filled, and that the manometer fluid is free of contamination.

7.3 Level and zero the manometer (if used). Inspect all pitot lines and check for leaks; repair or replace lines if necessary.

7.4 Turn on the flow system fan and allow the flow to stabilize; the test section velocity should be about 909 m/min or 15.2 m/s ~~{3000 ft/min}~~-(3000 ft/min). Seal the Type S entry port.

7.5 Determine an appropriate calibration point. Use the following guidelines:

7.5.1 For isolated Type S pitot tubes (or pitot tube-thermocouple combinations), select a calibration point at or near the center of the duct.

7.5.2 For pitobe assemblies, choose a point for which probe blockage effects are minimal; the point should be as close to the center of the duct as possible. To determine whether a given point will be acceptable for use as a calibration point, make a projected-area model of the pitobe assembly (Fig. 5), with the impact openings of the Type S pitot tube centered at the point. For assemblies without external sheaths (Fig. 5(a)), the point will be acceptable if the theoretical probe blockage, calculated as shown in Fig. 5, is less than or equal to 2 %. For assemblies with external sheaths (Fig. 5(b)), the point will be acceptable if the theoretical probe blockage is 3 % or less **(5)**.

7.6 Connect the standard pitot tube to the differential-pressure gage. Position the standard tube at the calibration point; the tip of the tube should be pointed directly into the flow. Particular care should be taken in aligning the tube, to avoid yaw and pitch angle errors. Once the standard pitot tube is in position, seal the entry port surrounding the tube.

7.7 Take a differential-pressure reading with the standard pitot tube; record this value in a data table similar to the one shown in Fig. 6. Remove the standard pitot tube from the duct and disconnect it from the differential pressure gage. Seal the standard pitot entry port.

7.8 Connect the Type S pitot tube to the differential-pressure gage and open the Type S entry port. Insert and align the Type S pitot tube so that its “A” side impact opening is positioned at the calibration point, and is pointed directly into the flow. Seal the entry port surrounding the tube.

7.9 Take a differential-pressure reading with the Type S pitot tube; record this value in the data table. Remove the Type S pitot tube from the duct; disconnect the tube from the differential-pressure gage. Seal the Type S entry port.

7.10 Repeat procedures 7.6 through 7.9, until three pairs of differential-pressure readings have been obtained.

7.11 Repeat procedures 7.6 through 7.10 above for the “B” side of the Type S pitot tube.

7.12 For pitobe assemblies in which the free space between the pitot tube and nozzle (dimension *x*, Fig. 7) is less than 19.0 mm (¾ in.) with a 12.7-mm ~~{½-in.}~~-in.) inside diameter sampling nozzle in place, the value of the Type S pitot tube coefficient will be a function of the free space, which is, in turn, dependent upon nozzle size **(6)**; therefore, for these assemblies, a separate calibration should be done, in accordance with procedures 7.6 through 7.11, with each of the commonly used nozzle sizes in place. Single-velocity calibration at the midpoint of the normal working range is suitable for this purpose **(7)**, even though nozzles larger than 6.35-mm ~~{¼-in.}~~-in.) inside diameter are not ordinarily used for isokinetic sampling at velocities around 909 m/min or 15.2 m/s ~~{3000 ft/min}~~-(3000 ft/min).

**8. Calculation**

8.1 Calculate the value of the Type S pitot tube coefficient for each of the six pairs of differential-pressure readings (three from side A and three from side B), as follows:

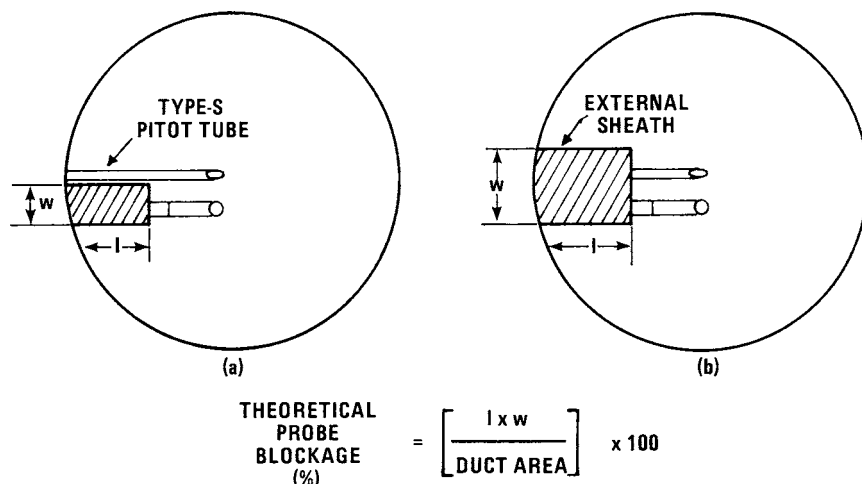

**FIG. 5 Projected-Area Models for Typical Pitobe Assemblies**

PITOT TUBE IDENTIFICATION NUMBER: \_\_\_\_\_ DATE: \_\_\_\_\_  
 CALIBRATED BY: \_\_\_\_\_

A SIDE CALIBRATION				
RUN NO.	$\Delta P_{std}$ in. H <sub>2</sub> O (mm H <sub>2</sub> O)	$\Delta P_{(s)}$ in. H <sub>2</sub> O (mm H <sub>2</sub> O)	$C_{p(s)}$	DEVIATION $C_{p(s)} - \bar{C}_p(A)$
1				
2				
3				
			$\bar{C}_p$ (SIDE A)	

B SIDE CALIBRATION				
RUN NO.	$\Delta P_{std}$ in. H <sub>2</sub> O (mm H <sub>2</sub> O)	$\Delta P_{(s)}$ in. H <sub>2</sub> O (mm H <sub>2</sub> O)	$C_{p(s)}$	DEVIATION $C_{p(s)} - \bar{C}_p(B)$
1				
2				
3				
			$\bar{C}_p$ (SIDE B)	

$$\text{AVERAGE DEVIATION} = \sigma (A \text{ OR } B) = \frac{\sum_{i=1}^3 |C_{p(s)} - \bar{C}_p(A \text{ OR } B)|}{3} \leftarrow \text{MUST BE } \leq 0.0$$

$$|\bar{C}_p(\text{SIDE A}) - \bar{C}_p(\text{SIDE B})| \leftarrow \text{MUST BE } \leq 0.01$$

NOTE—1 in. H<sub>2</sub>O = 0.249 kPa; 1 mm H<sub>2</sub>O = 0.0098 kPa.

FIG. 6 Calibration Data Table, Single-Velocity Calibration

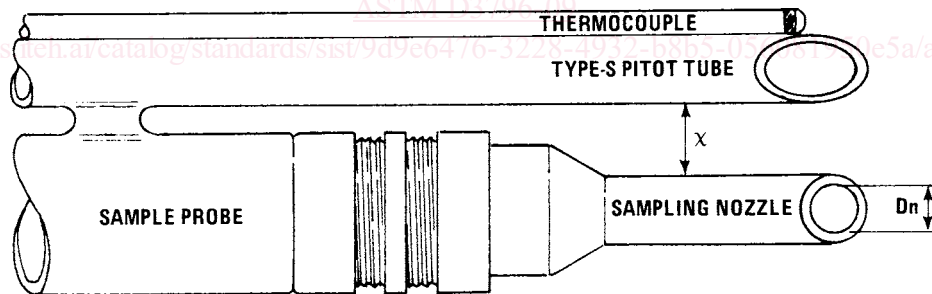

NOTE—This figure shows pitot tube-nozzle separation distance ( $x$ ); the Type S pitot tube coefficient is a function of  $x$ , if  $x < 3/4$  in. where  $D_n = 1/2$  in.

FIG. 7 Typical Pitot Assembly

mm in.

13	1/2
19	3/4
76	3

where:

$C_p(s)$  = Type S pitot tube coefficient,

$C_p(std)$  = coefficient of standard pitot tube,

$\Delta P_{std}$  = differential pressure measured by standard pitot tube, kPa (in. H<sub>2</sub>O or mm H<sub>2</sub>O), and

$\Delta P_s$  = differential pressure measured by Type S pitot tube, kPa (in. H<sub>2</sub>O or mm H<sub>2</sub>O).

8.2 Calculate the mean A and B side coefficients of the Type S pitot tube, as follows:

where:

$\bar{C}_p$  (side A or B) = mean A or B side coefficient, and

$C_p$  (s) = individual value of Type S pitot coefficient, A or B side.

8.3 Subtract the mean A side coefficient from the mean B side coefficient. Take the absolute value of this difference.

8.4 Calculate the deviation of each of the A and B side coefficient values from its mean value, as follows:

8.5 Calculate the average deviation from the mean, for both the A and B sides of the pitot tube, as follows:

where  $\sigma$ (side A or B) = average deviation of  $C_p$  (s) values from the mean, A or B side.

**9. Precision and Bias**

9.1 *Precision*—The results of the calibration should not be considered suspect unless the following criteria fail to be met:

9.1.1 The absolute value of the difference between the mean A and B side coefficients (see 8.3) is less than or equal to 0.01.

9.1.2 The A and B side values of average deviation are less than or equal to 0.01.

9.1.3 If criterion 9.1.1, or 9.1.2, or both, are not met, the Type S pitot tube may not be suitable for use. In such cases, repeat the calibration procedure two more times; do not use the Type S pitot tube unless both of these runs give satisfactory results.

9.2 *Bias*—In general, the mean A and B side coefficient values obtained by this method will be accurate to within  $\pm 3\%$  over the normal working range (7).

9.2.1 When a calibrated pitot assembly is used to measure velocity in ducts having diameters (or equivalent diameters) between 305 and 915 mm [ $\pm 12$  (12 and 36 in.)], the calibration coefficients may need to be adjusted slightly to compensate for probe blockage effects. A procedure for making these adjustments is outlined in Annex A2. Conventional pitot assemblies are not recommended for use in ducts smaller than 305 mm [ $\pm 12$  (12 in.)] in diameter.

9.2.2 A Type S pitot tube shall be calibrated before its initial use. Thereafter, if the tube has been significantly damaged by field use (for example, if the impact openings are noticeably bent out of shape, nicked, or misaligned), it should be repaired and recalibrated. The data collected should be evaluated in the light of this recalibration.

9.2.3 The coefficient of a calibrated isolated Type S pitot tube may change if the isolated tube is attached to a source sampling probe and used as a pitot assembly. The isolated and assembly coefficient values can only be considered equal when the intercomponent spacing requirements illustrated in Figs. 8-10 and are met.

**10. Keywords**

10.1 calibration; pitot tube; Type S pitot tube

ASTM D3796-09

<https://standards.iteh.ai/catalog/standards/sist/9d9e6476-3228-4932-b8b5-056081950e5a/astm-d3796-09>

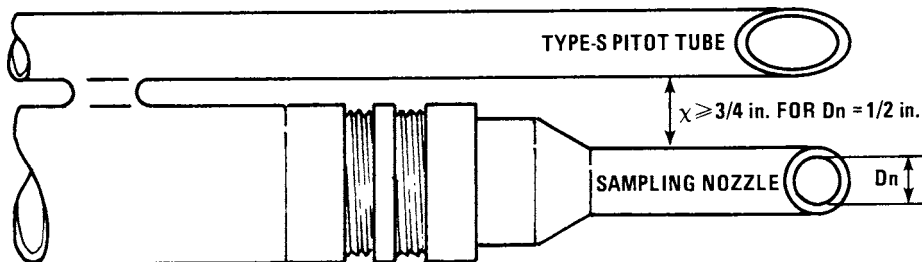

FIG. 8 Minimum Pitot-Nozzle Separation Needed to Prevent Aerodynamic Interference

mm	in.
13	1/2
19	3/4
76	3