

INTERNATIONAL STANDARD

ISO 2347

Fourth edition
1987-12-01



INTERNATIONAL ORGANIZATION FOR STANDARDIZATION
ORGANISATION INTERNATIONALE DE NORMALISATION
МЕЖДУНАРОДНАЯ ОРГАНИЗАЦИЯ ПО СТАНДАРТИЗАЦИИ

Road vehicles — M14 × 1,25 compact spark-plugs with conical seating and their cylinder head housing

Véhicules routiers — Bougies d'allumage M14 × 1,25 « compacte » à siège conique et leur logement dans la culasse

ITC STANDARD PREVIEW

(standards.iteh.ai)

ISO 2347:1987

<https://standards.iteh.ai/catalog/standards/sist/416c93ce-e03a-4f30-905f-c448537a81a8/iso-2347-1987>

Foreword

ISO (the International Organization for Standardization) is a worldwide federation of national standards bodies (ISO member bodies). The work of preparing International Standards is normally carried out through ISO technical committees. Each member body interested in a subject for which a technical committee has been established has the right to be represented on that committee. International organizations, governmental and non-governmental, in liaison with ISO, also take part in the work.

Draft International Standards adopted by the technical committees are circulated to the member bodies for approval before their acceptance as International Standards by the ISO Council. They are approved in accordance with ISO procedures requiring at least 75 % approval by the member bodies voting.

International Standard ISO 2347 was prepared by Technical Committee ISO/TC 22, *Road vehicles*.

iTeh STANDARD PREVIEW
(standards.iteh.ai)

This fourth edition cancels and replaces the third edition (ISO 2347:1981), of which it constitutes a technical revision. <https://standards.iteh.ai/catalog/standards/sist/416c93ce-e03a-4f30-905f-c448537a81a8/iso-2347-1987>

Users should note that all International Standards undergo revision from time to time and that any reference made herein to any other International Standard implies its latest edition, unless otherwise stated.

Road vehicles — M14 × 1,25 compact spark-plugs with conical seating and their cylinder head housing

1 Scope and field of application

This International Standard specifies the main characteristics of M14 × 1,25 compact spark-plugs with conical seating and their cylinder head housing, for use with spark-ignition engines.

2 References

ISO 68, *ISO general purpose screw threads — Basic profile.*

ISO 261, *ISO general purpose metric screw threads — General plan.*

ISO 965-1, *ISO general purpose metric screw threads — Tolerances — Part 1 : Principles and basic data.*

ISO 965-3, *ISO general purpose metric screw threads — Tolerances — Part 3 : Deviations for constructional threads.*

3 Requirements

3.1 Terminals

The spark-plug terminal may be either the solid post or the threaded type. If nuts are used they shall have the same external dimensions as those of the solid post terminal. See figures 1a) and 2b).

3.2 Dimensions and thread (see figures 1 and 2)

3.2.1 Length dimensions

The length dimensions are measured from a gauging plane defined by diameter $\boxed{14,8}$ on the seating.

3.2.2 Dimensions of spark-plug housing in the cylinder head

The length dimensions 7,9 min. and 2 max. in the cylinder head are measured from a gauging plane defined by diameter $\boxed{14,8}$ on the seating.

Dimension 7,9 min. shall ensure that no threaded portion of the plug reach may enter the combustion chamber when the spark-plug is tightened with the torque specified in 3.4.

3.2.3 Threads

3.2.3.1 Spark-plug and cylinder head

The threads of M14 × 1,25 spark-plugs and the corresponding tapped holes in the cylinder head shall conform to ISO 68, ISO 261, ISO 965-1 and ISO 965-3. Their limiting dimensions and their tolerance classes shall be as specified in 3.2.3.1.1 and 3.2.3.1.2 respectively.

3.2.3.1.1 Limiting dimensions

The limiting dimensions shall be as given in the table.

Table

Dimensions in millimetres

Dimension		Plug thread (on finished plug)	Tapped hole in cylinder head
Major diameter	max.	13,937	not specified
	min.	13,725	14
Pitch diameter	max.	13,125	13,368
	min.	12,993	13,188
Minor diameter	max.	12,404	12,912
	min.	12,181 ¹⁾	12,647

1) With a root radius $>0,125$ mm (0,1 P).

3.2.3.1.2 Tolerance classes

The tolerance classes of thread M14 × 1,25 of finished spark-plugs and of the corresponding tapped holes in the cylinder head shall be as follows :

- 6e for spark-plugs (see note 1);
- 6H for tapped holes in the cylinder head.

NOTES

1 In order that spark-plugs complying with this International Standard can be fitted in existing cylinder heads also in extreme cases, the value for the *maximum truncation* of the minor diameter of the spark-plug base has been slightly reduced with respect to the ISO value.

This maximum value of the minor diameter was calculated from a distance of $H/6$ for the *maximum truncation* instead of the value given by the formula in ISO 965-1 : 1980, clause 11, according to the formula given below :

$$\begin{aligned} \text{Minor diameter, maximum} &= d_1 - e_s - 2(H/4 - H/6) \\ &= 12,647 - 0,063 - 0,180 \\ &= 12,647 - 0,243 = 12,404 \end{aligned}$$

The value for the *basic profile* remains the same as for the ISO thread (12,647 - 0,063 = 12,584).

2 The initial clearance $e = 0,063$ mm between the pitch diameters of the thread and of the tapped hole is intended to prevent the possibility of seizure, as a result of combustion deposits on the bare threads, when removing the spark-plugs.

This clearance is also intended to enable spark-plugs with threads in accordance with this International Standard to be fitted in existing tapped holes.

3.2.3.2 Threaded terminal

For spark-plugs with a threaded-type terminal, the thread tolerance class of the terminal [see figure 1 b)] shall be 6e.

NOTE — Depending on manufacturing processes, class 7e is acceptable on the finished product.

Nuts for use with threaded terminals shall have internal threads to 6H tolerance prior to assembly on the threaded post.

3.3 Other dimensions of spark-plug and housing in the cylinder head

The other dimensions shall be as indicated in figures 1 and 2.

The contour of the insulator is optional; however, between the reference planes defined for spark-plugs with solid post terminal by the dimensions 20 and 24 mm and for spark-plugs with threaded terminal by the dimensions 17 and 21 mm, its largest diameter shall be $10,5 \pm 0,3$ mm.

Details not specified are left to the manufacturer's choice.

3.4 Installation tightening torque

The installation torque values apply to new spark-plugs without lubricant on the threads. If threads are lubricated, the torque value shall be reduced by approximately one-third to avoid overstressing.

The spark-plugs shall be tightened with a torque of 10 to 20 N·m in aluminium and cast iron cylinder heads.

NOTE — Engine manufacturers may specify a different torque for the first spark-plug installation.

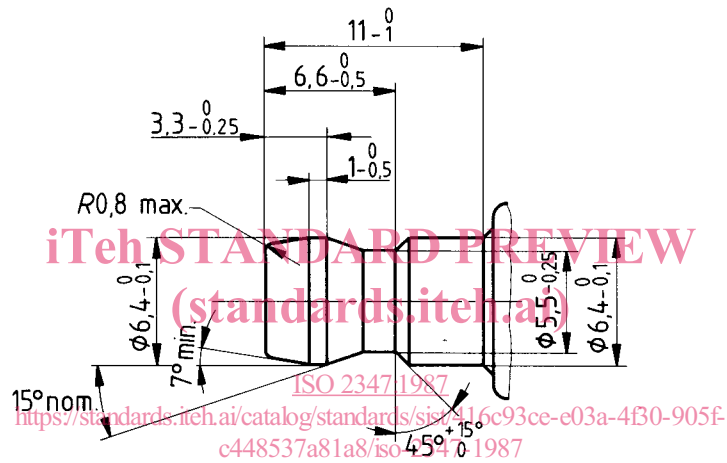
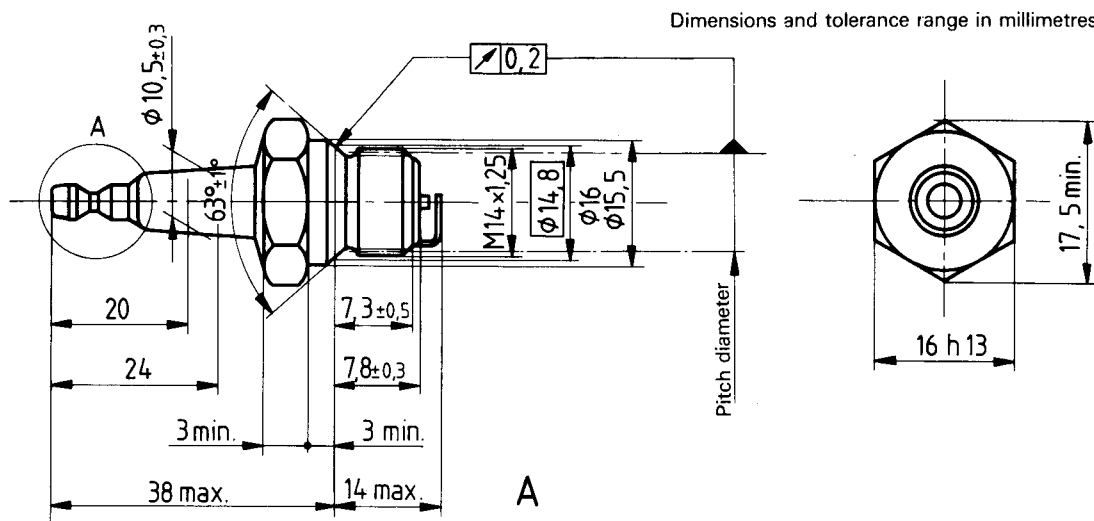

a) solid post terminal

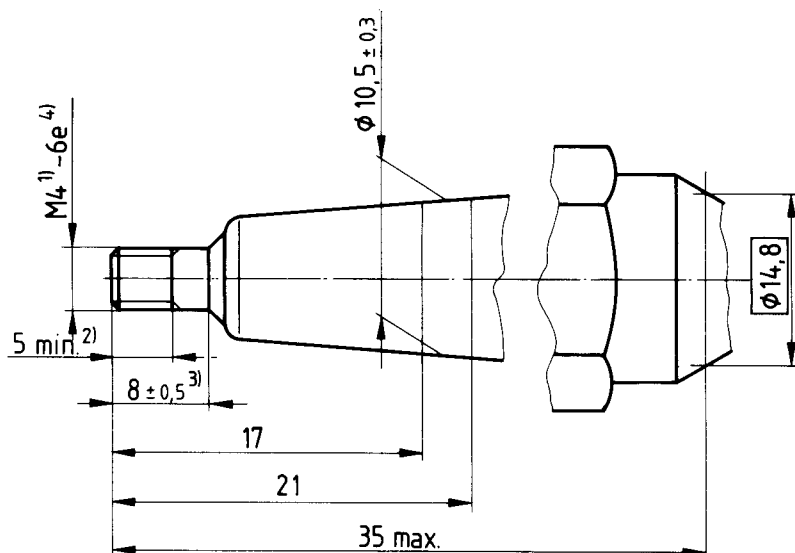

b) threaded terminal

Figure 1 – M14 × 1,25 compact spark-plugs with conical seating

- 1) 0,7 mm pitch complying with ISO 68 and with ISO 261.
- 2) Usable length of thread.
- 3) Cylindrical part.
- 4) Depending on manufacturing processes, class 7e is acceptable on the finished product.

Dimensions and tolerance range in millimetres

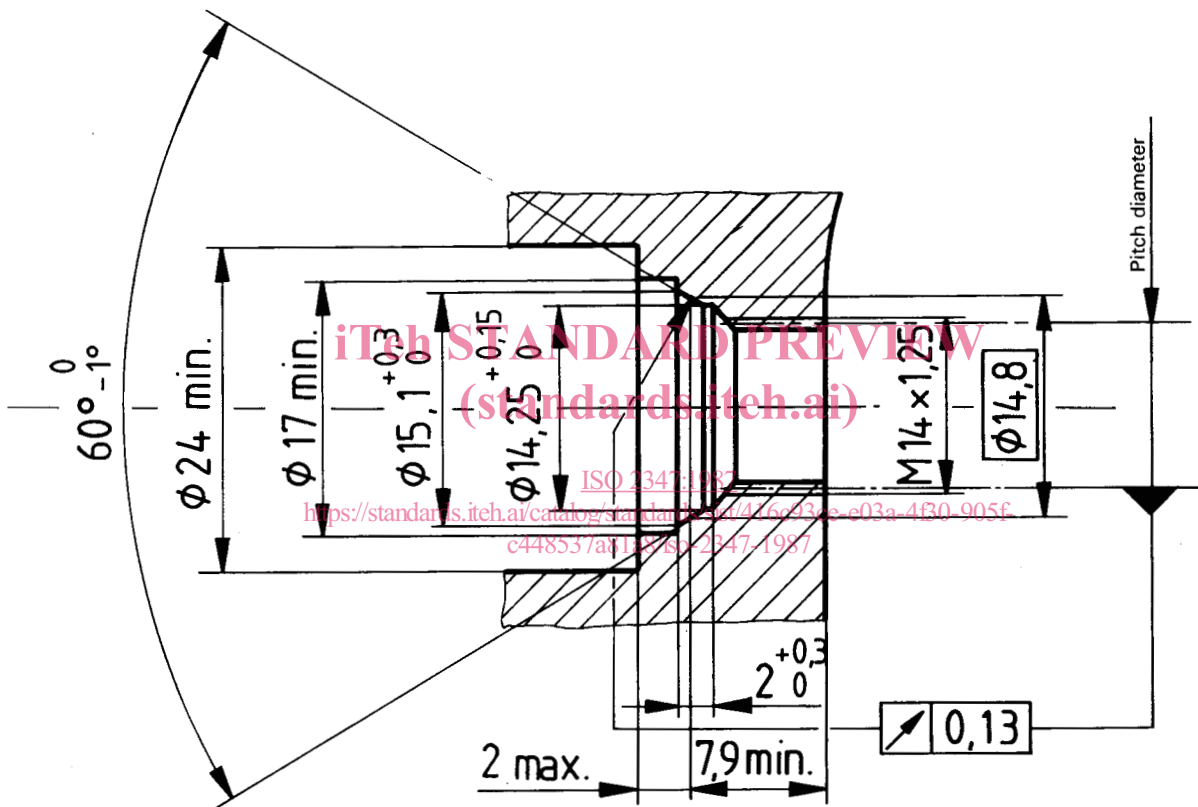

Figure 2 — Housing of the spark-plugs in the cylinder head

iTeh STANDARD PREVIEW
(standards.iteh.ai)

ISO 2347:1987

<https://standards.iteh.ai/catalog/standards/sist/416c93ce-e03a-4f30-905f-c448537a81a8/iso-2347-1987>

iTeh STANDARD PREVIEW
(standards.iteh.ai)

ISO 2347:1987

<https://standards.iteh.ai/catalog/standards/sist/416c93ce-e03a-4f30-905f-c448537a81a8/iso-2347-1987>

UDC 621.43.045

Descriptors : road vehicles, internal combustion engines, ignition systems, spark plugs, specifications, dimensions.

Price based on 4 pages
