



Designation: ~~D 1557-00~~ Designation: D1557 - 09

Standard Test Methods for Laboratory Compaction Characteristics of Soil Using Modified Effort (56,000 ft-lbf/ft³(2,700 kN-m/m³))¹

This standard is issued under the fixed designation D1557; the number immediately following the designation indicates the year of original adoption or, in the case of revision, the year of last revision. A number in parentheses indicates the year of last reapproval. A superscript epsilon (ϵ) indicates an editorial change since the last revision or reapproval.

This standard has been approved for use by agencies of the Department of Defense.

1. Scope*

1.1 These test methods cover laboratory compaction methods used to determine the relationship between molding water content and dry unit weight of soils (compaction curve) compacted in a 4- or 6-in. (101.6- or 152.4-mm) diameter mold with a 10,00-lbf. (44,548-N) rammer dropped from a height of 18.00 in. (457.2 mm) producing a compactive effort of 56,000~~56 000~~ ft-lbf/ft³ (2,700~~2700~~ kN-m/m³).

~~NOTE1—Soils and soil-aggregate mixtures should be regarded as natural occurring fine- or coarse-grained soils or composites or mixtures of natural soils, or mixtures of natural and processed soils or aggregates such as silt, gravel, or crushed rock.~~

~~NOTE2—The equipment and procedures are the same as proposed by the U.S. Corps of Engineers in 1945. The modified effort test (see 3.2.2.1—The equipment and procedures are the same as proposed by the U.S. Corps of Engineers in 1945. The modified effort test (see 3.1.2) is sometimes referred to as the Modified Proctor Compaction Test.~~

1.1.1 Soils and soil-aggregate mixtures are to be regarded as natural occurring fine- or coarse-grained soils, or composites or mixtures of natural soils, or mixtures of natural and processed soils or aggregates such as gravel or crushed rock. Hereafter referred to as either soil or material.

1.2 These test methods apply only to soils (materials) that have 30 % or less by mass of their particles retained on the $\frac{3}{4}$ -in. (19.0-mm) sieve.

~~NOTE3—For relationships between unit weights and water contents of soils with 30% or less by weight of material retained on the $\frac{3}{4}$ -in. (19.0-mm) sieve to unit weights and water contents of the fraction passing the $\frac{3}{4}$ -in. (19.0-mm) sieve, see Practice D 4718D 4718-in. (19.0-mm) sieve and have not been previously compacted in the laboratory; that is, do not reuse compacted soil.~~

1.2.1 For relationships between unit weights and molding water contents of soils with 30 % or less by weight of material retained on the $\frac{3}{4}$ -in. (19.0-mm) sieve to unit weights and molding water contents of the fraction passing the $\frac{3}{4}$ -in. (19.0-mm) sieve, see Practice D4718.

1.3 Three alternative methods are provided. The method used shall be as indicated in the specification for the material being tested. If no method is specified, the choice should be based on the material gradation.

1.3.1 Method A:

1.3.1.1 *Mold*—4-in. (101.6-mm) diameter.

1.3.1.2 *Material*—Passing No. 4 (4.75-mm) sieve.

1.3.1.3 *Layers*—Five.

1.3.1.4 *Blows per layer*—25.

1.3.1.5 *Use*—May be used if 20% or less by mass of the material is retained on the No. 4 (4.75-mm) sieve. *Usage*—May be used if 25 % or less by mass of the material is retained on the No. 4 (4.75-mm) sieve. However, if 5 to 25 % by mass of the material is retained on the No. 4 (4.75-mm) sieve, Method A can be used but oversize corrections will be required (See 1.4) and there are no advantages to using Method A in this case.

1.3.1.6 *Other Use*—If this method is not specified, materials that meet these gradation requirements may be tested using Methods B or C. —If this gradation requirement cannot be met, then Methods B or C may be used.

1.3.2 Method B:

1.3.2.1 *Mold*—4-in. (101.6-mm) diameter.

¹ This standard is under the jurisdiction of ASTM Committee

¹ These test methods are under the jurisdiction of ASTM Committee D18 on Soil and Rock and are the direct responsibility of Subcommittee D18.03 on Texture, Plasticity and Density Characteristics of Soils.

Current edition approved March 10, 2000. Published September 2000. Originally published as D 1557-58. Last previous edition D 1557-91 (1998).

Current edition approved Oct. 1, 2009. Published October 2009. Originally approved in 1958. Last previous edition approved in 2007 as D1557-07. DOI: 10.1520/D1557-09.

*A Summary of Changes section appears at the end of this standard.

1.3.2.2 *Material*—Passing $\frac{3}{8}$ -in. (9.5-mm) sieve.

1.3.2.3 *Layers*—Five.

1.3.2.4 *Blows per layer*—25.

1.3.2.5 *Use*—Shall be used if more than 20% by mass of the material is retained on the No. 4 (4.75-mm) sieve and 20% or less by mass of the material is retained on the $\frac{3}{8}$ -in. (9.5-mm) sieve. *Usage*—May be used if 25 % or less by mass of the material is retained on the $\frac{3}{8}$ -in. (9.5-mm) sieve. However, if 5 to 25 % of the material is retained on the $\frac{3}{8}$ -in. (9.5-mm) sieve, Method B can be used but oversize corrections will be required (See 1.4). In this case, the only advantages to using Method B rather than Method C are that a smaller amount of sample is needed and the smaller mold is easier to use.

1.3.2.6 *Other Use*—If this method is not specified, materials that meet these gradation requirements may be tested using Method C. *Other Usage*—If this gradation requirement cannot be met, then Method C may be used.

1.3.3 *Method C:*

1.3.3.1 *Mold*—6-in. (152.4-mm) diameter.

1.3.3.2 *Material*—Passing $\frac{3}{4}$ -in. (19.0-mm) sieve.

1.3.3.3 *Layers*—Five.

1.3.3.4 *Blows per layer*—56.

1.3.3.5 *Use*—Shall be used if more than 20% by mass of the material is retained on the $\frac{3}{8}$ -in. (9.53-mm) sieve and less than 30% by mass of the material is retained on the $\frac{3}{4}$ -in. (19.0-mm) sieve. *Usage*—May be used if 30 % or less (see 1.4) by mass of the material is retained on the $\frac{3}{4}$ -in. (19.0-mm) sieve.

1.3.4 The 6-in. (152.4-mm) diameter mold shall not be used with Method A or B.

NOTE4—Results have been found to vary slightly when a material is tested at the same compactive effort in different size molds.

1.4 If the test specimen contains more than 5% by mass of oversize fraction (coarse fraction) and the material will not be included in the test, corrections must be made to the unit weight and water content of the test specimen or to the appropriate field in-place density test specimen using Practice D 4718². Results have been found to vary slightly when a material is tested at the same compactive effort in different size molds, with the smaller mold size typically yielding larger values of unit weight and density (1).

1.5 This test method will generally produce well defined maximum dry unit weight for non-free draining soils. If this test method is used for free draining soils the maximum unit weight may not be well defined, and can be less than obtained using Test Methods D 4253².

1.4 If the test specimen contains more than 5 % by mass of oversize fraction (coarse fraction) and the material will not be included in the test, corrections must be made to the unit weight and molding water content of the test specimen or to the appropriate field in-place unit weight (or density) test specimen using Practice D4718.

1.6 The values in inch-pound units are to be regarded as the standard. The values stated in SI units are provided for information only.

1.6 In the engineering profession it is customary practice to use, interchangeably, units representing both mass and force, unless dynamic calculations ($F=Ma$) are involved. This implicitly combines two separate systems of units, that is, the absolute system and the gravimetric system. It is scientifically undesirable to combine the use of two separate systems within a single standard. This test method has been written using inch-pound units (gravimetric system) where the pound (lbf) represents a unit of force. The use of mass (lbm) is for convenience of units and is not intended to convey the use is scientifically correct. Conversions are given in the SI system in accordance with IEEE/ASTM SI 10². The use of balances or scales recording pounds of mass (lbm), or the recording of density in lbm/ft

1.5 This test method will generally produce a well-defined maximum dry unit weight for non-free draining soils. If this test method is used for free-draining soils the maximum unit weight may not be well defined, and can be less than obtained using Test Methods D4253.

1.6 All observed and calculated values shall conform to the guidelines for significant digits and rounding established in Practice D6026, unless superseded by these test methods.

1.6.1 For purposes of comparing measured or calculated value(s) with specified limits, the measured or calculated value(s) shall be rounded to the nearest decimal or significant digits in the specified limits.

1.6.2 The procedures used to specify how data are collected/recorded or calculated in this standard are regarded as the industry standard. In addition, they are representative of the significant digits that generally should be retained. The procedures used do not consider material variation, purpose for obtaining the data, special purpose studies, or any considerations for the user's objectives; it is common practice to increase or reduce significant digits of reported data to be commensurate with these considerations. It is beyond the scope of these test methods to consider significant digits used in analytical methods for engineering design.

1.7 The values in inch-pound units are to be regarded as the standard. The values stated in SI units are provided for information only, except for units of mass. The units for mass are given in SI units only, g or kg.

1.7.1 It is common practice in the engineering profession to concurrently use pounds to represent both a unit of mass (lbm) and

² Annual Book of ASTM Standards, Vol 04.02.

² The boldface numbers in parentheses refer to the list of references at the end of this standard.

a force (lbf). This implicitly combines two separate systems of units; that is, the absolute system and the gravitational system. It is scientifically undesirable to combine the use of two separate sets of inch-pound units within a single standard. These test methods have been written using the gravitational system of units when dealing with the inch-pound system. In this system, the pound (lbf) represents a unit of force (weight). However, the use of balances or scales recording pounds of mass (lbm) or the recording of density in lbm/ft^3 should not be regarded as a nonconformance with this standard.

1.7.1.8 *This standard does not purport to address all of the safety concerns, if any, associated with its use. It is the responsibility of the user of this standard to establish appropriate safety and health practices and determine the applicability of regulatory limitations prior to use.*

2. Referenced Documents

2.1 ASTM Standards:

- ~~C127~~ [Test Method for Specific Gravity and Absorption of Coarse Aggregate](#)³
- ~~C127~~ [Test Method for Density, Relative Density \(Specific Gravity\), and Absorption of Coarse Aggregate](#)
- ~~C136~~ [Test Method for Sieve Analysis of Fine and Coarse Aggregates](#)² [Test Method for Sieve Analysis of Fine and Coarse Aggregates](#)
- ~~C670~~ [Practice for Preparing Precision and Bias Statements for Test Methods for Construction Materials](#)
- ~~D422~~ [Test Method for Particle-Size Analysis of Soils](#) ~~653~~ [Terminology Relating to Soil, Rock, and Contained Fluids](#)
- ~~D653~~ [Terminology Relating to Soil, Rock, and Contained Fluids](#)³
- ~~D698~~ ~~698~~ [Test Methods for Laboratory Compaction Characteristics of Soil Using Standard Effort](#) ~~12,400~~ [\(12 400 ft-lbf/ft³\)](#) ~~(600~~ [kN-m/m³\)](#) ~~(600 kN-m/m³)³)³~~
- ~~D854~~ [Test Method for Specific Gravity of Soils](#)³
- [Test Methods for Specific Gravity of Soil Solids by Water Pycnometer](#)
- ~~D2168~~ [Test Methods-Practices for Calibration of Laboratory Mechanical-Rammer Soil Compactors](#)
- ~~D2216~~ [Test Methods for Laboratory Determination of Water \(Moisture\) Content of Soil and Rock by Mass](#)
- ~~D2487~~ [Practice for Classification of Soils for Engineering Purposes \(Unified Soil Classification System\)](#)
- ~~D2488~~ [Practice for Description and Identification of Soils \(Visual-Manual Procedure\)](#)³
- ~~D4220~~ [Practices for Preserving and Transporting Soil Samples](#)³ [Practice for Description and Identification of Soils \(Visual-Manual Procedure\)](#)
- ~~D3740~~ [Practice for Minimum Requirements for Agencies Engaged in Testing and/or Inspection of Soil and Rock as Used in Engineering Design and Construction](#)
- ~~D4220~~ [Practices for Preserving and Transporting Soil Samples](#)
- ~~D4253~~ [Test Methods for Maximum Index Density and Unit Weight of Soils Using a Vibratory Table](#)
- ~~D4718~~ [Practice for Correction of Unit Weight and Water Content for Soils Containing Oversize Particles](#)
- ~~D4753~~ [Specification for Evaluating, Selecting and Specifying Balances and Scales For Use in Soil, Rock, and Construction Materials Testing](#)³ [Guide for Evaluating, Selecting, and Specifying Balances and Standard Masses for Use in Soil, Rock, and Construction Materials Testing](#)
- ~~D4914~~ [Test Methods for Density and Unit Weight of Soil and Rock in Place by the Sand Replacement Method in a Test Pit](#)
- ~~D5030~~ [Test Method for Density of Soil and Rock in Place by the Water Replacement Method in a Test Pit](#)
- ~~E1~~ [Specification for ASTM Thermometers](#) ~~D6026~~ [Practice for Using Significant Digits in Geotechnical Data](#)
- ~~D6913~~ [Test Methods for Particle-Size Distribution \(Gradation\) of Soils Using Sieve Analysis](#)
- ~~E11~~ [Specification for Wire-Cloth Sieves for Testing Purposes](#)⁵
- ~~E319~~ [Practice for the Evaluation of Single-Pan Mechanical Balances](#)⁵ [Specification for Woven Wire Test Sieve Cloth and Test Sieves](#)
- ~~IEEE/ASTM SI 10~~ ~~E319~~ [Practice for the Evaluation of Single-Pan Mechanical Balances](#)
- ~~IEEE/ASTM SI 10~~ [Standard for Use of the International System of Units \(SI\): The Modern Metric System](#)

3. Terminology

3.1 *Definitions*—See Terminology ~~D 653~~ ~~D 653~~ [Definitions](#): See Terminology [D653](#) for general definitions.

3.2 *Definitions of Terms Specific to This Standard*:

3.2.1

3.1.1 *molding water content, n*—the water content of the soil (material) specimen in the mold after it has been reconstituted and compacted.

3.1.2 *modified effort*—the term for the ~~56000 ft-lbf/ft³~~ in compaction testing, the term for the ~~56 000 ft-lbf/ft³~~ (2700 kN-m/m³) compactive effort applied by the equipment and methods of this test.

³ For referenced ASTM standards, visit the ASTM website, www.astm.org, or contact ASTM Customer Service at service@astm.org. For *Annual Book of ASTM Standards*, Vol 04.08, volume information, refer to the standard's Document Summary page on the ASTM website.

3.2.23.1.3 modified maximum dry unit weight, $\gamma_{d,max}$ (lb/ft³ (kN/m³))—the maximum value defined by the compaction curve for a compaction test using modified effort.

3.2.3 modified optimum water content, w_o (%)—the water content at which the soil can be compacted to the maximum dry unit weight using modified compactive effort.

3.2.4—in compaction testing, the maximum value defined by the compaction curve for a compaction test using modified effort.

3.1.4 modified optimum water content, w_{opt} (%)—in compaction testing, the water content at which the soil can be compacted to the maximum dry unit weight using modified compactive effort.

3.2 Definitions of Terms Specific to This Standard:

3.2.1 oversize fraction (coarse fraction), P_c (%)—the portion of total sample not used in performing the compaction test; it may be the portion of total sample retained on the No. 4 (4.75-mm), $\frac{3}{8}$ -in. (9.5-mm), or $\frac{3}{4}$ -in. (19.0-mm) sieve.

3.2.5—the portion of total specimen not used in performing the compaction test; it may be the portion of total specimen retained on the No. 4 (4.75-mm) sieve in Method A, $\frac{3}{8}$ -in. (9.5-mm) sieve in Method B, or $\frac{3}{4}$ -in. (19.0-mm) sieve in Method C.

3.2.2 test fraction (finer fraction), P_f (%)—the portion of the total sample/specimen used in performing the compaction test; it may be fraction passing the No. 4 (4.75-mm) sieve in Method A, minus passing the $\frac{3}{8}$ -in. (9.5-mm) sieve in Method B, or minus passing the $\frac{3}{4}$ -in. (19.0-mm) sieve in Method C.

4. Summary of Test Method

4.1 A soil at a selected molding water content is placed in five layers into a mold of given dimensions, with each layer compacted by 25 or 56 blows of a 10.00-lbf (44.548-N) rammer dropped from a distance of ~~18-in. (457-mm)~~, 18.00 in. (457.2 mm), subjecting the soil to a total compactive effort of about 56 000 ft—lbf/ft³ (2700 kN·m/m³). The resulting dry unit weight is determined. The procedure is repeated for a sufficient number of molding water contents to establish a relationship between the dry unit weight and the molding water content for the soil. This data, when plotted, represent a curvilinear relationship known as the compaction curve. The values of optimum water content and modified maximum dry unit weight are determined from the compaction curve.

5. Significance and Use

5.1 Soil placed as engineering fill (embankments, foundation pads, road bases) is compacted to a dense state to obtain satisfactory engineering properties such as, shear strength, compressibility, or permeability. Also, foundation soils are often compacted to improve their engineering properties. Laboratory compaction tests provide the basis for determining the percent compaction and water content needed to achieve the required engineering properties, and for controlling construction to assure that the required compaction and water contents are achieved.

5.2 During design of an engineered fill, shear, consolidation, permeability, or other tests require preparation of test specimens by compacting at some water content to some unit weight. It is common practice to first determine the optimum water content (

5.1 Soil placed as engineering fill (embankments, foundation pads, road bases) is compacted to a dense state to obtain satisfactory engineering properties such as shear strength, compressibility, or permeability. In addition, foundation soils are often compacted to improve their engineering properties. Laboratory compaction tests provide the basis for determining the percent compaction and molding water content needed to achieve the required engineering properties, and for controlling construction to assure that the required compaction and water contents are achieved.

NOTE 3—The degree of soil compaction required to achieve the desired engineering properties is often specified as a percentage of the modified maximum dry unit weight as determined using this test method. If the required degree of compaction is substantially less than the modified maximum dry unit weight using this test method, it may be practicable for testing to be performed using Test Method D698 and to specify the degree of compaction as a percentage of the standard maximum dry unit weight. Since more energy is applied for compaction using this test method, the soil particles are more closely packed than when D698 is used. The general overall result is a higher maximum dry unit weight, lower optimum moisture content, greater shear strength, greater stiffness, lower compressibility, lower air voids, and decreased permeability. However, for highly compacted fine-grained soils, absorption of water may result in swelling, with reduced shear strength and increased compressibility, reducing the benefits of the increased effort used for compaction (2). Use of D698, on the other hand, allows compaction using less effort and generally at a higher optimum moisture content. The compacted soil may be less brittle, more flexible, more permeable, and less subject to effects of swelling and shrinking. In many applications, building or construction codes may direct which test method, D698 or this one, should be used when specifying the comparison of laboratory test results to the degree of compaction of the in-place soil in the field.

5.2 During design of an engineered fill, testing performed to determine shear, consolidation, permeability, or other properties requires test specimens to be prepared by compacting the soil at a prescribed molding water content to obtain a predetermined unit weight. It is common practice to first determine the optimum water content (w_{opt}) and maximum dry unit weight ($\gamma_{d,max}$) by means of a compaction test. Test specimens are compacted at a selected molding water content (w), either wet or dry of optimum (w_{opt}) or at optimum (w_{opt}), and at a selected dry unit weight related to a percentage of maximum dry unit weight ($\gamma_{d,max}$). The selection of molding water content (w), either wet or dry of optimum (w_{opt}) or at optimum (w_{opt}) and the dry unit weight ($\gamma_{d,max}$) may be based on past experience, or a range of values may be investigated to determine the necessary percent of compaction.

5.3 Experience 5.3 Experience indicates that the methods outlined in 5.2 or the construction control aspects discussed in 5.1 are extremely difficult to implement or yield erroneous results when dealing with some soils. The following subsections describe typical problem soils, the problems encountered when dealing with such soils and possible solutions for these problems.

5.3.1 Oversize Fraction—Soils containing more than 30 % oversize fraction (material retained on the $\frac{3}{4}$ -in. (19-mm) sieve) are

a problem. For such soils, there is no ASTM test method to control their compaction and very few laboratories are equipped to determine the laboratory maximum unit weight (density) of such soils (USDI Bureau of Reclamation, Denver, CO and U.S. Army Corps of Engineers, Vicksburg, MS). Although Test Methods D 4914 and D 5030 determine the “field” dry unit weight of such soils, they are difficult and expensive to perform.

5.3.1.1 One method to design and control the compaction of such soils is to use a test fill to determine the required degree of compaction and the method to obtain that compaction. Then use a method specification to control the compaction. Components of a method specification typically contain the type and size of compaction equipment to be used, the lift thickness, acceptable range of molding water content, and number of passes.

NOTE 54—Success in executing the compaction control of an earthwork project, especially when a method specification is used, is highly dependent upon the quality and experience of the contractor and inspector.

5.3.1.2 Another method is to apply the use of density correction factors developed by the USDI Bureau of Reclamation (13,24) and U.S. Corps of Engineers (35). These correction factors may be applied for soils containing up to about 50 to 70 % oversize fraction. Both agencies use a different term for these density correction factors. The USDI Bureau of Reclamation uses *D* ratio (or *D* – VALUE), while the U.S. Corps of Engineers uses Density Interference Coefficient (*I_c*).

5.3.1.3 The use of the replacement technique (Test Method D1557–78, Method D), in which the oversize fraction is replaced with a finer fraction, is inappropriate to determine the maximum dry unit weight, γ_{dmax} , of soils containing oversize fractions (35).

5.3.2 Degradation—Soils containing particles that degrade during compaction are a problem, especially when more degradation occurs during laboratory compaction than field compaction, the typical case. Degradation typically occurs during the compaction of a granular-residual soil or aggregate. When degradation occurs, the maximum dry-unit weight increases (41) so that the resulting laboratory maximum value is not representative of field conditions. Often, in these cases, the maximum dry unit weight is impossible to achieve in the field.

5.3.2.1 Again for soils subject to degradation, the use of test fills and method specifications may help. Use of replacement techniques is not correct.

5.3.3 Gap Graded—Gap-graded soils (soils containing many large particles with limited small particles) are a problem because the compacted soil will have larger voids than usual. To handle these large voids, standard test methods (laboratory or field) typically have to be modified using engineering judgement.

NOTE 5—The quality of the result produced by this standard is dependent on the competence of the personnel performing it, and the suitability of the equipment and facilities used. Agencies that meet the criteria of Practice D3740 are generally considered capable of competent and objective testing/sampling/inspection/etc. Users of this standard are cautioned that compliance with Practice D3740 does not in itself assure reliable results. Reliable results depend on many factors; Practice D3740 provides a means of evaluating some of those factors.

6. Apparatus

6.1 Mold Assembly—The molds shall be cylindrical in shape, made of rigid metal and be within the capacity and dimensions indicated in 6.1.1 or 6.1.2 and Fig. 1 and Fig. 2. See also Table 1. The walls of the mold may be solid, split, or tapered. The “split” type may consist of two half-round sections, or a section of pipe split along one element, which can be securely locked together to form a cylinder meeting the requirements of this section. The “tapered” type shall have an internal diameter taper that is uniform and not more than 0.200 in./ft (16.7 mm/m) of mold height. Each mold shall have a base plate and an extension collar assembly, both made of rigid metal and constructed so they can be securely attached and easily detached from the mold. The extension collar assembly shall have a height extending above the top of the mold of at least 2.0 in. (50.8(51 mm)) which may include an upper section that flares out to form a funnel, provided there is at least a 0.75-in. (19.0-mm)(19-mm) straight cylindrical section beneath it. The extension collar shall align with the inside of the mold. The bottom of the base plate and bottom of the centrally recessed area that accepts the cylindrical mold shall be planar within ± 0.005 in. (± 0.1 mm).

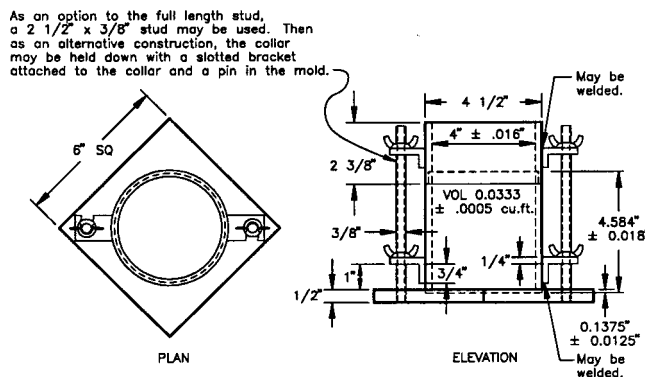

NOTE 1—See Table 1 for SI equivalents.

FIG. 1 Cylindrical Mold, 4.0-in.

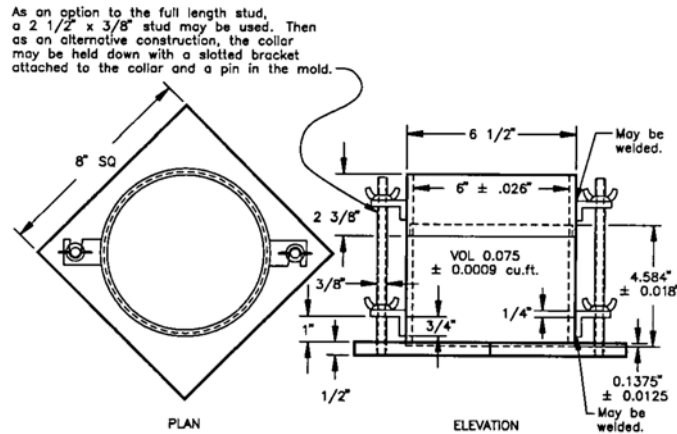

NOTE 1—See Table 1 for SI equivalents.

FIG. 2 Cylindrical Mold, 6.0-in.

TABLE-2 1 Metric/SI Equivalents for Figs. 1 and 2

in.	mm
0.016	0.41
0.026	0.66
0.032	0.81
0.028	0.71
1/2	12.70
23/6	60.33
2 1/2	63.50
2 5/8	66.70
4	101.60
4 1/2	114.30
4.584	116.43
4 3/4	120.60
6	152.40
6 1/2	165.10
6 5/8	168.30
6 3/4	171.40
8 1/4	208.60
ft ³	cm ³
1/30 (0.0333)	943
0.0005	14
1/13.333 (0.0750)	2,124
0.0011	31

6.1.1 *Mold, 4 in.*—A mold having a 4.000 ± 0.016 -in. (101.6 ± 0.4 -mm) average inside diameter, a height of 4.584 ± 0.018 in. (116.4 ± 0.5 mm) and a volume of 0.0333 ± 0.0005 ft³ (944 ± 14 cm³ (943.0 ± 14.0 cm³)). A mold assembly having the minimum required features is shown in Fig. 1.

6.1.2 *Mold, 6 in.*—A mold having a 6.000 ± 0.026 -in. (152.4 ± 0.7 -mm) average inside diameter, a height of 4.584 ± 0.018 in. (116.4 ± 0.5 mm), and a volume of 0.0750 ± 0.0009 ft³ (2124 ± 25 cm³). A mold assembly having the minimum required features is shown in Fig. 2.

6.2 *Rammer*—A rammer, either manually operated as described further in 6.2.1 or mechanically operated as described in 6.2.2. The rammer shall fall freely through a distance of 18.00 ± 0.05 in. (457.2 ± 1.3 mm) from the surface of the specimen. The massweight of the rammer shall be 10.00 ± 0.02 lbm (4.54 lbf (44.48 ± 0.01 N, or mass of 4.5364 ± 0.009 kg), except that the massweight of the mechanical rammers may be adjusted as described in Test Methods D 2168 (see Note 6). The striking face of the rammer shall be planar and circular, except as noted in 6.2.2.1, with a diameter when new of 2.000 ± 0.005 in. (50.80 ± 0.13 mm). The rammer shall be replaced if the striking face becomes worn or bellied to the extent that the diameter exceeds 2.000 ± 0.01 in. (50.80 ± 0.25 mm).

NOTE 6—It is a common and acceptable practice in the inch-pound system to assume that the mass of the rammer is equal to its mass determined using either a kilogram or pound balance and 1 lbf is equal to 1 lbm or 0.4536 kg or 1 N is equal to 0.2248 lbf or 0.1020 kg.

6.2.1 *Manual Rammer*—It is a common and acceptable practice to determine the weight of the rammer using either a kilogram or pound balance and assume 1 lbf is equivalent to 0.4536 kg, 1 lbf is equivalent to 1 lbm, or 1 N is equivalent to 0.2248 lbf or 0.1020 kg.

6.2.1 *Manual Rammer*—The rammer shall be equipped with a guide sleeve that has sufficient clearance that the free fall of the rammer shaft and head is not restricted. The guide sleeve shall have at least four vent holes at each end (eight holes total) located