

ISO/TC 22/SC 32

Secretariat: JISC

Voting begins on:
2020-04-17

Voting terminates on:
2020-06-12

Road vehicles — Connectors for the electrical connection of towing and towed vehicles — Connectors for electronically monitored charging systems with 12 V or 24 V nominal supply voltage

Véhicules routiers — Connecteurs pour liaisons électriques entre véhicules tracteurs et véhicules tractés — Raccords pour systèmes de charge contrôlés électroniquement à tension d'alimentation nominale de 12 V ou 24 V

RECIPIENTS OF THIS DRAFT ARE INVITED TO SUBMIT, WITH THEIR COMMENTS, NOTIFICATION OF ANY RELEVANT PATENT RIGHTS OF WHICH THEY ARE AWARE AND TO PROVIDE SUPPORTING DOCUMENTATION.

IN ADDITION TO THEIR EVALUATION AS BEING ACCEPTABLE FOR INDUSTRIAL, TECHNOLOGICAL, COMMERCIAL AND USER PURPOSES, DRAFT INTERNATIONAL STANDARDS MAY ON OCCASION HAVE TO BE CONSIDERED IN THE LIGHT OF THEIR POTENTIAL TO BECOME STANDARDS TO WHICH REFERENCE MAY BE MADE IN NATIONAL REGULATIONS.



Reference number
ISO/FDIS 25981:2020(E)

iTeh STANDARD PREVIEW
(standards.iteh.ai)
Full standard:
<https://standards.iteh.ai/catalog/standards/sist/6837ad1f-27c7-414e-bb70-7e8878e09b57/iso-fdis-25981>



COPYRIGHT PROTECTED DOCUMENT

© ISO 2020

All rights reserved. Unless otherwise specified, or required in the context of its implementation, no part of this publication may be reproduced or utilized otherwise in any form or by any means, electronic or mechanical, including photocopying, or posting on the internet or an intranet, without prior written permission. Permission can be requested from either ISO at the address below or ISO's member body in the country of the requester.

ISO copyright office
CP 401 • Ch. de Blandonnet 8
CH-1214 Vernier, Geneva
Phone: +41 22 749 01 11
Fax: +41 22 749 09 47
Email: copyright@iso.org
Website: www.iso.org

Published in Switzerland

Contents

Page

Foreword	iv
1 Scope	1
2 Normative references	1
3 Terms and definitions	1
4 Dimensional	2
4.1 General.....	2
4.2 Plug.....	2
4.3 Socket.....	2
4.4 Park socket.....	2
5 Application of the connector	6
5.1 General.....	6
5.2 Contact allocation.....	6
5.3 Contact designation.....	7
5.4 Terminals.....	7
5.5 Connecting cable.....	7
5.6 Colouring of plug and socket.....	7
6 Tests and specific requirements	7
6.1 General.....	7
6.2 Mismatching.....	7
6.2.1 Purpose.....	7
6.2.2 Test procedure.....	8
6.2.3 Requirement.....	8
6.3 Connection and disconnection.....	8
6.4 Endurance.....	8
6.5 Mechanical strength of mounting features.....	8
Annex A (normative) Minimum functionality of the monitoring device	9
Bibliography	10

Foreword

ISO (the International Organization for Standardization) is a worldwide federation of national standards bodies (ISO member bodies). The work of preparing International Standards is normally carried out through ISO technical committees. Each member body interested in a subject for which a technical committee has been established has the right to be represented on that committee. International organizations, governmental and non-governmental, in liaison with ISO, also take part in the work. ISO collaborates closely with the International Electrotechnical Commission (IEC) on all matters of electrotechnical standardization.

The procedures used to develop this document and those intended for its further maintenance are described in the ISO/IEC Directives, Part 1. In particular the different approval criteria needed for the different types of ISO documents should be noted. This document was drafted in accordance with the editorial rules of the ISO/IEC Directives, Part 2 (see www.iso.org/directives).

Attention is drawn to the possibility that some of the elements of this document may be the subject of patent rights. ISO shall not be held responsible for identifying any or all such patent rights. Details of any patent rights identified during the development of the document will be in the Introduction and/or on the ISO list of patent declarations received (see www.iso.org/patents).

Any trade name used in this document is information given for the convenience of users and does not constitute an endorsement.

For an explanation on the voluntary nature of standards, the meaning of ISO specific terms and expressions related to conformity assessment, as well as information about ISO's adherence to the World Trade Organization (WTO) principles in the Technical Barriers to Trade (TBT) see the following URL: www.iso.org/iso/foreword.html

This document was prepared by Technical Committee, ISO/TC 22 *Road vehicles*, Subcommittee SC 32, *Electrical and electronic components and general system aspects*.

This second edition cancels and replaces the first edition (ISO 25981:2004), which has been technically revised and includes the following changes:

- references to ISO 4009 removed;
- corrections to [Figure 2](#) Socket.

Any feedback or questions on this document should be directed to the user's national standards body. A complete listing of these bodies can be found at www.iso.org/members.html.

Road vehicles — Connectors for the electrical connection of towing and towed vehicles — Connectors for electronically monitored charging systems with 12 V or 24 V nominal supply voltage

1 Scope

This document specifies dimensional characteristics, contact allocation, tests and requirements of 7-pole connectors for electrical connections of electronically monitored charging systems of towing and towed vehicles. The electronic monitoring system is designed to detect 12 V and 24 V nominal supply voltage and to limit the current to 50 A, and this is a connector without any braking capacity.

This electrical connection is intended for use with separable truck-trailer combinations in order to connect an additional battery pack of the trailer with the generator of the truck using an electronically monitored charging system. Additional battery packs in trailers are basically used with tailgate lifts, electrical forklifts or other technical equipment with high current consumption.

This document further specifies a park socket used to receive and store the plug when it is disconnected.

2 Normative references

The following documents are referred to in the text in such a way that some or all of their content constitutes requirements of this document. For dated references, only the edition cited applies. For undated references, the latest edition of the referenced document (including any amendments) applies.

ISO 4141 (all parts), *Road vehicles — Multi-core connecting cables*

ISO 4091, *Road vehicles — Connectors for the electrical connection of towing and towed vehicles — Definitions, tests and requirements*

ISO 7638-1, *Road vehicles — Connectors for the electrical connection of towing and towed vehicles — Part 1: Connectors for braking systems and running gear of vehicles with 24 V nominal supply voltage*

ISO 7638-2, *Road vehicles — Connectors for the electrical connection of towing and towed vehicles — Part 2: Connectors for braking systems and running gear of vehicles with 12 V nominal supply voltage*

ISO 12098, *Road vehicles — Connectors for the electrical connection of towing and towed vehicles — 15-pole connector for vehicles with 24 V nominal supply voltage*

IEC 60512-13-5, *Connectors for electronic equipment — Tests and measurements — Part 13-5: Mechanical operation tests — Test 13e: Polarizing and keying method*

3 Terms and definitions

For the purposes of this document, the terms and definitions given in ISO 4091 apply.

ISO and IEC maintain terminological databases for use in standardization at the following addresses:

- ISO Online browsing platform: available at <https://www.iso.org/obp>
- IEC Electropedia: available at <http://www.electropedia.org/>

4 Dimensional

4.1 General

Details not specified are at the manufacturer's discretion.

The contacts shall be floating and shall align to the datum position when plug and socket are engaged.

4.2 Plug

Dimensions of the plug shall be in accordance with [Figure 1](#).

The locking lever design shall take into consideration the space required for screws used to fasten the socket (see section B-B in [Figure 2](#)).

4.3 Socket

Dimensions of the socket shall be in accordance with [Figure 2](#).

The cover is shown in the open position. It shall close automatically when the plug is disconnected.

4.4 Park socket

Dimensions of the park socket shall be in accordance with [Figure 3](#).

The cover is shown in the open position. It shall close automatically when the plug is disconnected.

ITEH STANDARD PREVIEW
(standard.iteh.ai)
Full standard available on
<https://standards.iteh.ai/catalog/standards/sist/6837ad1f-27c7-414e-bb70-7e8878e09b57/iso-fdis-25981>

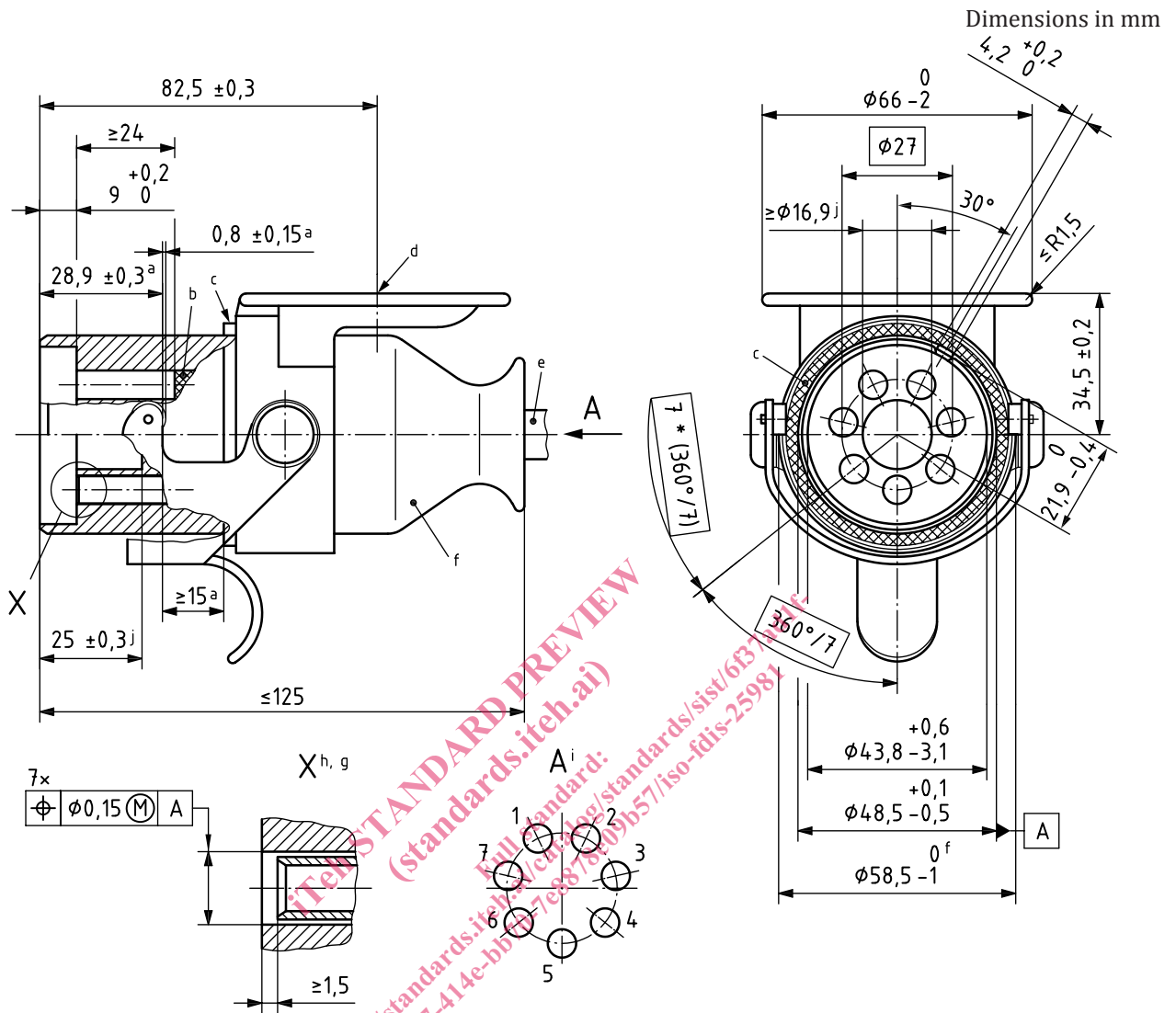

Key

- a Dimension refers to the locking lever in its locked position.
- b Plug housing with 7 bushings and coding.
- c The sealing ring shall be mounted such that it cannot become detached under normal use.
- d Centre of cover rest.
- e See ISO 4141-3 for correct sealing.
- f Other housing designs are permitted in compliance with the maximum distance of 58 mm for the locking lever.
- g Contact bushing with 6,0 mm² terminal for contacts 1 to 4 and 1,0 mm² terminal for contacts 5 to 7.
- h Spring tube.
- i Contact numbers.
- j Minimum space required for the ejection from the socket.

Figure 1 — Plug

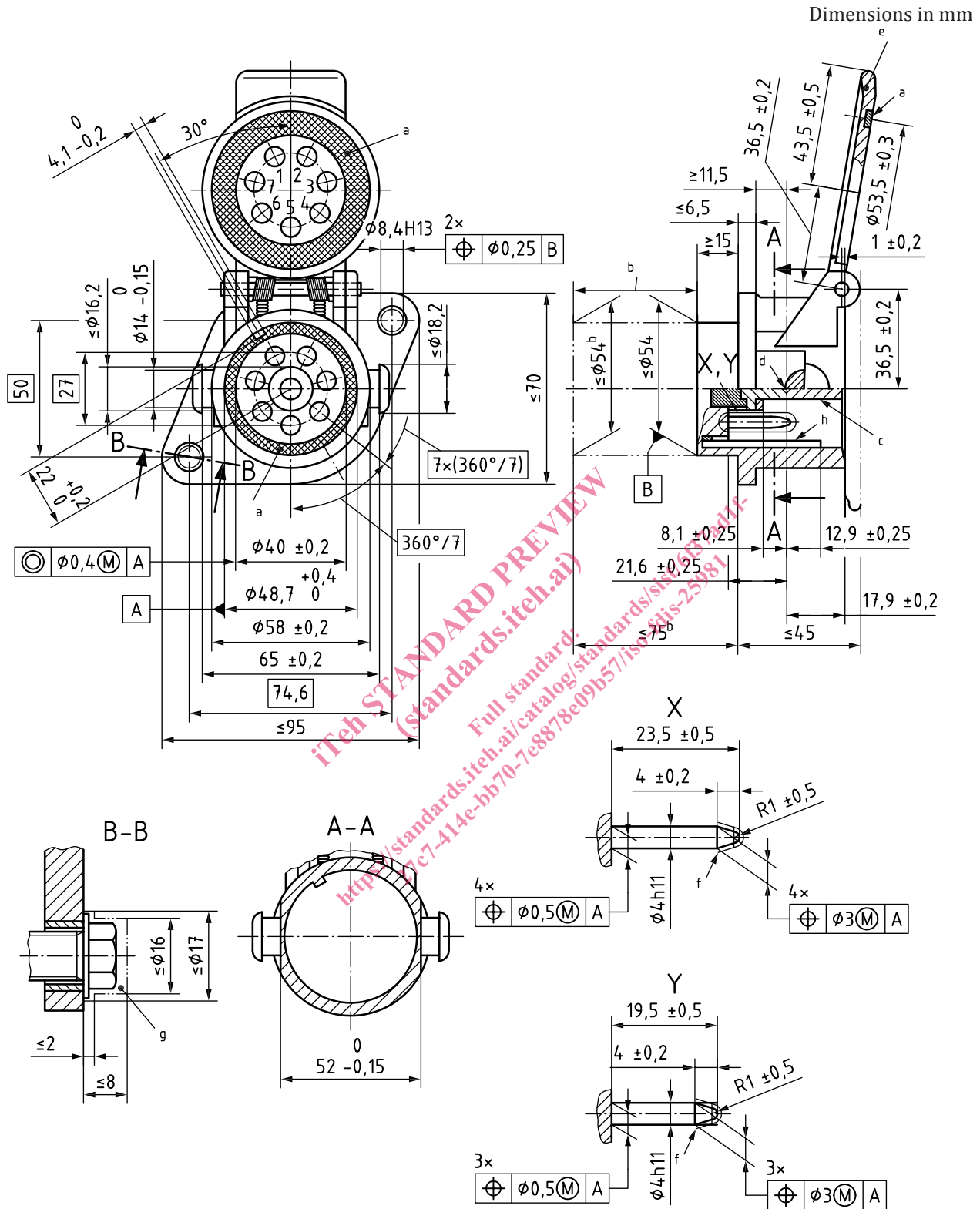

Key

- X contacts 1 to 4 with 6,0 mm² terminal and 23,5 mm length
- Y contacts 5 to 7 with 1,0 mm² terminal and 19,5 mm length
- a The sealing ring shall be mounted such that it cannot become detached under normal use.
- b For existing products for which the cable outlet is mounted from the rear, the outside diameter of the outlet may be larger with the vehicle manufacturer's agreement. However, to ensure socket exchangeability, it is recommended to allow for future applications that the maximum outside diameter be 54 mm over a maximum length of 75 mm. See ISO 4141-3 for correct sealing.

- c Spring loaded ejector optional.
- d Reference point for engaged locking lever.
- e Opening angle of cover 120° min.
- f This area shall be smooth and burr free.
- g Minimum space required for screws used to fasten the socket.
- h Coding is shown 150° rotated to indicate depth of coding.

Figure 2 — Socket

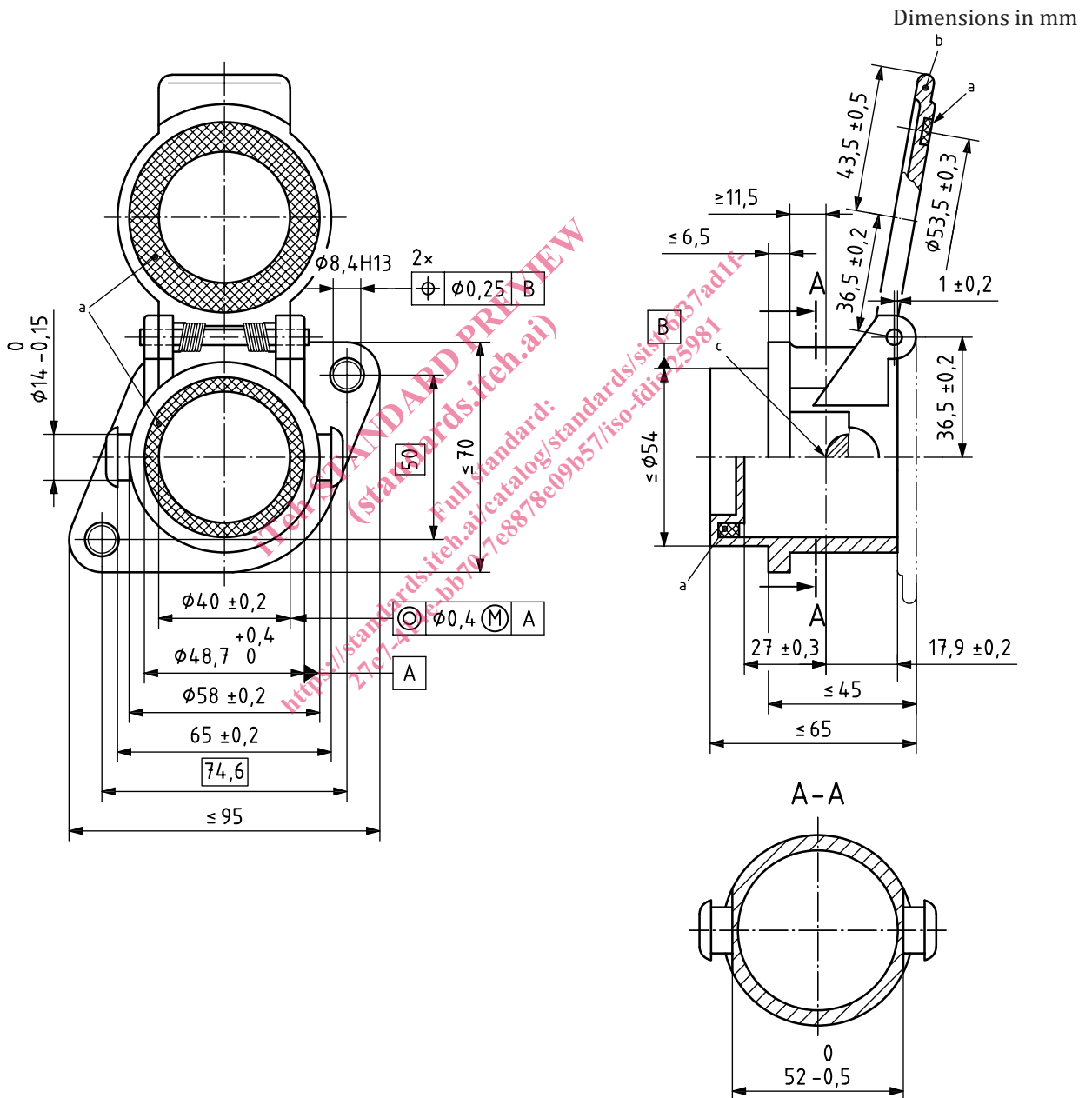

Figure 3 — Park socket