**Road vehicles — Ergonomic and
performance aspects of Camera
Monitor Systems — Requirements and
test procedures**

*Véhicules routiers — Aspects ergonomiques et de performance des
caméras embarquées — Exigences et procédures d'essai*

iTeh Standards

(<https://standards.iteh.ai>)

Document Preview

[ISO 16505:2019](https://standards.iteh.ai/catalog/standards/iso/fd6c00ff-d934-46a8-b135-bf15a145fe05/iso-16505-2019)

<https://standards.iteh.ai/catalog/standards/iso/fd6c00ff-d934-46a8-b135-bf15a145fe05/iso-16505-2019>



iTeh Standards
(<https://standards.iteh.ai>)
Document Preview

[ISO 16505:2019](https://standards.iteh.ai/catalog/standards/iso/fd6c00ff-d934-46a8-b135-bf15a145fe05/iso-16505-2019)

<https://standards.iteh.ai/catalog/standards/iso/fd6c00ff-d934-46a8-b135-bf15a145fe05/iso-16505-2019>



COPYRIGHT PROTECTED DOCUMENT

© ISO 2019

All rights reserved. Unless otherwise specified, or required in the context of its implementation, no part of this publication may be reproduced or utilized otherwise in any form or by any means, electronic or mechanical, including photocopying, or posting on the internet or an intranet, without prior written permission. Permission can be requested from either ISO at the address below or ISO's member body in the country of the requester.

ISO copyright office
CP 401 • Ch. de Blandonnet 8
CH-1214 Vernier, Geneva
Phone: +41 22 749 01 11
Fax: +41 22 749 09 47
Email: copyright@iso.org
Website: www.iso.org

Published in Switzerland

Contents

	Page
Foreword	v
Introduction	vi
1 Scope	1
2 Normative references	1
3 Terms and definitions	1
3.1 Vehicle related terms and definitions.....	1
3.2 Mirror related terms and definitions.....	2
3.3 Camera related terms and definitions.....	12
3.4 Monitor related terms and definitions.....	15
3.5 Camera Monitor System based terms and definitions.....	23
4 Symbols and abbreviated terms	33
5 General information and use case definitions	36
6 Requirements	40
6.1 System documentation.....	40
6.2 Intended use.....	41
6.2.1 Default view.....	41
6.2.2 Adjusted default view.....	41
6.2.3 Temporary modified view.....	41
6.2.4 Luminance and contrast adjustment.....	42
6.2.5 Overlays.....	42
6.3 Operating readiness (system availability).....	42
6.4 Field of view.....	43
6.5 Magnification and resolution.....	43
6.5.1 Average magnification factor.....	43
6.5.2 Minimum magnification factor.....	43
6.5.3 Resolution (MTF).....	44
6.6 Magnification aspect ratio.....	45
6.7 Monitor integration inside the vehicle.....	45
6.8 Image quality.....	46
6.8.1 Monitor isotropy.....	46
6.8.2 Luminance and contrast rendering.....	47
6.8.3 Colour rendering.....	47
6.8.4 Artefacts.....	48
6.8.5 Sharpness and depth of field.....	49
6.8.6 Geometric distortion.....	49
6.8.7 Further image quality requirements.....	50
6.9 Time behaviour.....	50
6.9.1 Frame rate.....	50
6.9.2 Image formation time.....	50
6.9.3 System latency.....	50
6.10 Failure behaviour.....	50
6.11 Quality and further ergonomic requirements.....	50
6.11.1 Needs of older persons.....	51
6.12 Influences from weather and environment.....	51
7 Test methods	51
7.1 System documentation.....	51
7.2 Intended use.....	51
7.2.1 Default view.....	51
7.2.2 Adjusted default view.....	51
7.2.3 Temporary modified view.....	52
7.2.4 Luminance and contrast adjustment.....	52
7.2.5 Overlays.....	52

7.3	Operating readiness (system availability).....	52
7.4	Field of view.....	54
7.5	Magnification and resolution.....	54
	7.5.1 Average magnification factor.....	54
	7.5.2 Minimum magnification factor.....	55
	7.5.3 Resolution (MTF).....	57
7.6	Magnification aspect ratio.....	60
7.7	Monitor integration inside the vehicle.....	60
7.8	Image quality.....	61
	7.8.1 Monitor isotropy.....	61
	7.8.2 Luminance and contrast rendering.....	63
	7.8.3 Colour rendering.....	71
	7.8.4 Artefacts.....	74
	7.8.5 Sharpness, resolution, and depth of field.....	75
	7.8.6 Geometric distortion.....	77
	7.8.7 Further Image quality requirements.....	77
7.9	Time behaviour.....	77
	7.9.1 Frame rate.....	77
	7.9.2 Image formation time.....	77
	7.9.3 System latency.....	77
7.10	Failure behaviour.....	78
7.11	Quality and further ergonomic requirements.....	79
	7.11.1 Needs of older persons.....	79
7.12	Influences from weather and environment.....	79
8	Functional safety.....	79
Annex A	(normative) Standard application on UN Regulation No. 46 class II and IV mirrors in commercial vehicles.....	80
Annex B	(informative) Formula applications, explanations, and guidelines.....	85
Annex C	(informative) Calculation of the dimensional magnification and of a correction factor to obtain the angular magnification.....	120
Annex D	(informative) Complementary information for resolution measurement.....	125
Annex E	(informative) Correlation between Resolution (MTF) and spatial frequency measured using SFR method for depth of field evaluation or sharpness evaluation.....	134
Annex F	(informative) Complementary charts and method for long distance measurements.....	139
Annex G	(informative) Distortion measurement.....	142
Bibliography	149

Foreword

ISO (the International Organization for Standardization) is a worldwide federation of national standards bodies (ISO member bodies). The work of preparing International Standards is normally carried out through ISO technical committees. Each member body interested in a subject for which a technical committee has been established has the right to be represented on that committee. International organizations, governmental and non-governmental, in liaison with ISO, also take part in the work. ISO collaborates closely with the International Electrotechnical Commission (IEC) on all matters of electrotechnical standardization.

The procedures used to develop this document and those intended for its further maintenance are described in the ISO/IEC Directives, Part 1. In particular, the different approval criteria needed for the different types of ISO documents should be noted. This document was drafted in accordance with the editorial rules of the ISO/IEC Directives, Part 2 (see www.iso.org/directives).

Attention is drawn to the possibility that some of the elements of this document may be the subject of patent rights. ISO shall not be held responsible for identifying any or all such patent rights. Details of any patent rights identified during the development of the document will be in the Introduction and/or on the ISO list of patent declarations received (see www.iso.org/patents).

Any trade name used in this document is information given for the convenience of users and does not constitute an endorsement.

For an explanation of the voluntary nature of standards, the meaning of ISO specific terms and expressions related to conformity assessment, as well as information about ISO's adherence to the World Trade Organization (WTO) principles in the Technical Barriers to Trade (TBT) see www.iso.org/iso/foreword.html.

This document was prepared by Technical Committee ISO/TC 22, *Road vehicles*, Subcommittee SC 35, *Lighting and visibility*.

Any feedback or questions on this document should be directed to the user's national standards body. A complete listing of these bodies can be found at www.iso.org/members.html.

This second edition cancels and replaces the first edition (ISO 16505:2015), of which it constitutes a minor revision.

The main changes compared to the previous edition are as follows:

- [6.1](#) has been added, and all subsequent subclauses in [Clause 6](#) have been renumbered, in order to align with the subclause structure in [Clause 7](#).

Any feedback or questions on this document should be directed to the user's national standards body. A complete listing of these bodies can be found at www.iso.org/members.html.

Introduction

The purpose of this document is to give minimum safety, ergonomic, and performance requirements and test methods for Camera Monitor Systems (CMS) to replace mandatory inside and outside rearview mirrors for road vehicles (e.g. classes I to IV as defined in UN Regulation No. 46). This document can follow updates of referred national regulations that influence the included contents.

Where possible, the requirements established for a CMS providing a specific legally prescribed field of view are based on the properties of conventional state of the art mirror systems providing that field of view.

The CMS is treated as a functional system in regard to requirement definitions and performance tests.

This document outlines general requirements and test methods regarding the basic aspects of CMS; e.g. intended use, operating readiness, field of view, magnification, etc.

Furthermore, this document outlines requirements and test methods regarding the necessary object size and resolution provided by the CMS. Besides the properties of the mirror system to be replaced, those requirements are also based on physical aspects of the human operator (e.g. visual acuity).

The given requirements follow the assumption, that the CMS provides an ideal mapping of the real-world scene. To correspond to reality, this document also provides requirements and test methods for all relevant parameters that worsen the ideal mapping (e.g. isotropy or artefacts).

Finally, this document gives requirements and test methods regarding the aspects of time behaviour and failure behaviour.

All requirements are established to be as generic as possible, i.e. that these are possible to apply to any of the covered rearview mirrors. If additional or specific information is required for certain mirrors, these are provided in separate annexes.

This document declares that CMS replacing legally prescribed mirrors have to be considered as safety-relevant systems and therefore, relevant safety standards (e.g. ISO 26262) have to be considered.

<https://standards.iteh.ai/catalog/standards/iso/fd6c00ff-d934-46a8-b135-bf15a145fe05/iso-16505-2019>

Road vehicles — Ergonomic and performance aspects of Camera Monitor Systems — Requirements and test procedures

1 Scope

This document gives minimum safety, ergonomic, and performance requirements for Camera Monitor Systems to replace mandatory inside and outside rearview mirrors for road vehicles (e.g. classes I to IV as defined in UN Regulation No. 46). It addresses Camera Monitor Systems (CMS) that will be used in road vehicles to present the required outside information of a specific field of view inside the vehicle. These specifications are intended to be independent of different camera and display technologies unless otherwise stated explicitly. Advanced driver assistance systems (ADAS), such as parking aids, are not part of this document.

NOTE 1 Mirror classes V and VI (as defined in UN Regulation No. 46) are not in scope of this document since the requirements are already defined in UN Regulation No. 46.

NOTE 2 The definitions and requirements in this document are formulated with regard to a system structure, where one camera captures one legally prescribed field of view and one monitor displays one legally prescribed field of view. Of course, also other system structures (e.g. with one monitor displaying two legally prescribed fields of view) are within the scope of this document. For those systems, either the system supplier or the vehicle manufacturer has to prove that the resulting system fulfils the requirements given in [Clause 6](#).

NOTE 3 Whenever the phrases “field of view” or “field of vision” are used, then both have the same meaning and are to be used in parallel.

2 Normative references

There are no normative references in this document.

3 Terms and definitions

For the purposes of this document, the following terms and definitions apply.

ISO and IEC maintain terminological databases for use in standardization at the following addresses:

- ISO Online browsing platform: available at <https://www.iso.org/obp>
- IEC Electropedia: available at <http://www.electropedia.org/>

3.1 Vehicle related terms and definitions

3.1.1 vehicle

vehicle with a combustion engine and/or electric driving motor, intended for use on the road, with or without external body components added, having a permissible maximum mass of at least 400 kg and a maximum design speed equal to or exceeding 50 km/h

Note 1 to entry: Vehicles of categories M1, M2, M3, N1, N2 and N3 (see UN Regulation No. 46).

[SOURCE: ISO 13043:2011, 3.1]

3.1.2
vehicle coordinate system

positive x-axis pointing into the opposite of the forward movement direction of the vehicle, the z-axis being orthogonal to the ground plane pointing upwards and the y-axis pointing to the right seen in forward movement direction thus forming a right-handed coordinate system

3.1.3
driver's ocular points

points that are uniquely defined for each vehicle

Note 1 to entry: See [Figure 1](#).

Note 2 to entry: These points are related to data given by the vehicle manufacturer following definitions of the responsible national body.

EXAMPLE "The driver's ocular points" means two points 65 mm apart and 635 mm vertically above point *R* of the driver's seat as defined in Annex B. The straight line joining these points runs perpendicular to the vertical longitudinal median plane of the vehicle. The centre of the segment joining the two ocular points is in a vertical longitudinal plane which has to pass through the centre of the driver's designated seating position, as specified by the vehicle manufacturer.

3.1.4
driver ocular reference point
ORP

middle point between the two ocular points of the driver

Note 1 to entry: See [Figure 1](#).

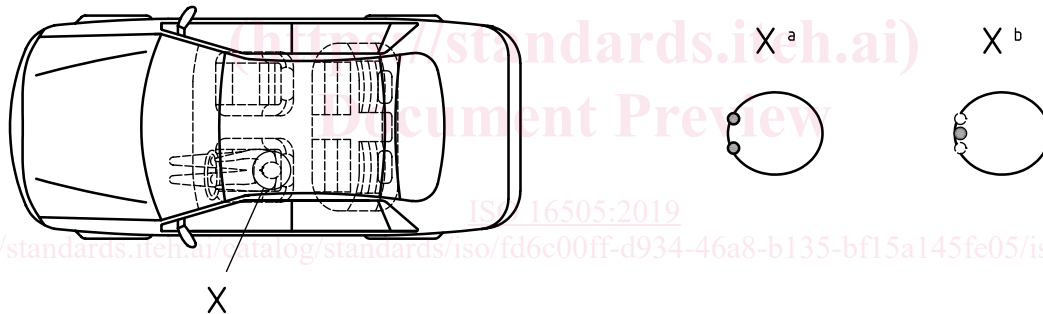

- a Ocular points.
- b Ocular reference point.

Figure 1 — Driver ocular reference point

EXAMPLE The two ocular points of the driver uses 635 mm vertically above point *R* as shown in the example given in *driver's ocular points* ([3.1.3](#)).

3.2 Mirror related terms and definitions

3.2.1
mirror

device with a reflective surface mounted to the bodywork of a vehicle

Note 1 to entry: It is used to see the required outside information of a specific field of view by indirect vision.

Note 2 to entry: The definitions from *mirror distance to driver ocular reference point* ([3.2.2](#)) to *mirror angular resolution* ([3.2.28](#)) assume an ideal mirror and do not deal with artefacts like low quality surface, dirt, etc.

3.2.2

mirror distance to driver ocular reference point

distance from the driver ocular reference point to the centre of the mirror

Note 1 to entry: See [Figure 2](#).

Note 2 to entry: It is denoted as a_{mirror} and is measured in metres.

Note 3 to entry: The mirror distance to driver ocular reference point influences the resolution and the magnification requirements for a CMS replacing a mirror. The designed resolution and magnification of a CMS should take into account that this distance is usually lower than the maximum values given in the following subclauses.

3.2.3

maximum mirror distance to driver ocular reference point

<driver side>maximum value for a_{mirror} as found in existing homologated vehicles for the given mirror class on the driver side

Note 1 to entry: It is denoted as $a_{mirror/driver/max}$ and is measured in metres:

- for UN Regulation No. 46 class I mirrors, this value is defined as $a_{mirror/driver/max} = 1,05$ m;
- for UN Regulation No. 46 class II mirrors, this value is defined as $a_{mirror/driver/max} = 1,7$ m;
- for UN Regulation No. 46 class III mirrors, this value is defined as $a_{mirror/driver/max} = 1,2$ m;
- for UN Regulation No. 46 class IV mirrors, this value is defined as $a_{mirror/driver/max} = 1,7$ m.

Note 2 to entry: The above values represent the maximum distances for mass produced vehicles of MY 2013 (based upon 2013 survey).

Note 3 to entry: See [B.6.2](#) for more information on the values for class II and class IV mirrors.

3.2.4

maximum mirror distance to driver ocular reference point

<passenger side>maximum value for a_{mirror} as found in existing homologated vehicles for the given mirror class on the passenger side

Note 1 to entry: It is denoted as $a_{mirror/passenger/max}$ and is measured in metres:

- for UN Regulation No. 46 class II mirrors, this value is defined as $a_{mirror/passenger/max} = 2,6$ m;
- for UN Regulation No. 46 class III mirrors, this value is defined as $a_{mirror/passenger/max} = 1,9$ m;
- for UN Regulation No. 46 class IV mirrors, this value is defined as $a_{mirror/passenger/max} = 2,6$ m;
- for main mirrors on cab-over-engine type trucks according to Article 44 of Japanese Safety Regulations for Road Vehicles, this value is defined as $a_{mirror/passenger/max} = 2,5$ m;
- for main mirrors on motor vehicles with a passenger capacity of 11 persons or more according to Article 44 of Japanese Safety Regulations for Road Vehicles, this value is defined as $a_{mirror/passenger/max} = 2,5$ m.
- for mirrors on the other vehicle category in Japan refer to Article 44 of Japanese Safety Regulations for Road Vehicles.

Note 2 to entry: The above values represent the maximum distances for mass produced vehicles of MY 2013 (based upon 2013 survey).

Note 3 to entry: See [B.6.3](#) for more information on the values for class II and class IV mirrors.

Note 4 to entry: According to Article 44 of Japanese Safety Regulations for Road Vehicles main mirror means "Those mirrors used mainly for observing obstacles showing up around the rear portion on the left side of the vehicle". See [Figures B.5](#), [B.6](#), and [B.7](#).

3.2.5

mirror viewing angle

total angle between the ray leaving the eye-point and reaching an object after being reflected from the mirror surface, i.e. two times the angle between the driver's line of sight and the surface normal of the mirror

Note 1 to entry: See [Figure 3](#).

Note 2 to entry: It is denoted as β_{mirror} and is measured in degrees.

3.2.6

minimum mirror viewing angle

<driver side>minimum value for β_{mirror} as found in existing homologated vehicles for the given mirror class on the driver side

Note 1 to entry: It is denoted as $\beta_{mirror/driver/min}$ and is measured in degrees:

- for UN Regulation No. 46 class I mirrors, this value is defined as $\beta_{mirror/driver/min} = 20^\circ$;
- for UN Regulation No. 46 class II mirrors, this value is defined as $\beta_{mirror/driver/min} = 55^\circ$;
- for UN Regulation No. 46 class III mirrors, this value is defined as $\beta_{mirror/driver/min} = 30^\circ$;
- for UN Regulation No. 46 class IV mirrors, this value is defined as $\beta_{mirror/driver/min} = 55^\circ$.

Note 2 to entry: The above values represent the minimum angles for mass produced vehicles of MY 2013 (based upon 2013 survey) regarding the required field of view.

3.2.7

maximum mirror viewing angle

<driver side>maximum value for β_{mirror} as found in existing homologated vehicles for the given mirror class on the driver side

Note 1 to entry: It is denoted as $\beta_{mirror/driver/max}$ and is measured in degrees:

- for UN Regulation No. 46 class I mirrors, this value is defined as $\beta_{mirror/driver/max} = 65^\circ$;
- for UN Regulation No. 46 class II mirrors, this value is defined as $\beta_{mirror/driver/max} = 75^\circ$;
- for UN Regulation No. 46 class III mirrors, this value is defined as $\beta_{mirror/driver/max} = 65^\circ$;
- for UN Regulation No. 46 class IV mirrors, this value is defined as $\beta_{mirror/driver/max} = 125^\circ$.

Note 2 to entry: The above values represent the maximum angles for mass produced vehicles of MY 2013 (based upon 2013 survey) regarding the required field of view.

3.2.8

minimum mirror viewing angle

<passenger side>minimum value for β_{mirror} as found in existing homologated vehicles for the given mirror class on the passenger side

Note 1 to entry: It is denoted as $\beta_{mirror/passenger/min}$ and is measured in degrees:

- for UN Regulation No. 46 class II mirrors, this value is defined as $\beta_{mirror/passenger/min} = 80^\circ$;
- for UN Regulation No. 46 class III mirrors, this value is defined as $\beta_{mirror/passenger/min} = 55^\circ$;
- for UN Regulation No. 46 class IV, this value is defined as $\beta_{mirror/passenger/min} = 80^\circ$;
- for main mirrors on cab-over-engine type trucks according to Article 44 of Japanese Safety Regulations for Road Vehicles, this value is defined as $\beta_{mirror/passenger/min} = 54^\circ$;
- for main mirrors on motor vehicles with a passenger capacity of 11 persons or more according to Article 44 of Japanese Safety Regulations for Road Vehicles, this value is defined as $\beta_{mirror/passenger/min} = 50,5^\circ$.

- for mirrors on the other vehicle category in Japan refer to Article 44 of Japanese Safety Regulations for Road Vehicles.

Note 2 to entry: The above values represent the minimum angles for mass produced vehicles of MY 2013 (based upon 2013 survey) regarding the required field of view.

Note 3 to entry: According to Article 44 of Japanese Safety Regulations for Road Vehicles, main mirror means “Those mirrors used mainly for observing obstacles showing up around the rear portion on the left side of the vehicle”. See [Figures B.5](#), [B.6](#), and [B.7](#).

3.2.9

maximum mirror viewing angle

<passenger side>maximum value for β_{mirror} as found in existing homologated vehicles for the given mirror class on the passenger side

Note 1 to entry: It is denoted as $\beta_{mirror/passenger/max}$ and is measured in degrees:

- for UN Regulation No. 46 class II mirrors, this value is defined as $\beta_{mirror/passenger/max} = 95^\circ$;
- for UN Regulation No. 46 class III mirrors, this value is defined as $\beta_{mirror/passenger/max} = 85^\circ$;
- for UN Regulation No. 46 class IV mirrors, this value is defined as $\beta_{mirror/passenger/max} = 150^\circ$;
- for main mirrors on cab-over-engine type trucks according to Article 44 of Japanese Safety Regulations for Road Vehicles, this value is defined as $\beta_{mirror/passenger/max} = 111^\circ$;
- for main mirrors on motor vehicles with a passenger capacity of 11 persons or more according to Article 44 of Japanese Safety Regulations for Road Vehicles, this value is defined as $\beta_{mirror/passenger/max} = 64^\circ$.
- for mirrors on the other vehicle category in Japan refer to Article 44 of Japanese Safety Regulations for Road Vehicles.

Note 2 to entry: The above values represent the maximum angles for mass produced vehicles of MY 2013 (based upon 2013 survey) regarding the required field of view.

Note 3 to entry: According to Article 44 of Japanese Safety Regulations for Road Vehicles main mirror means “Those mirrors used mainly for observing obstacles showing up around the rear portion on the left side of the vehicle”. See [Figures B.5](#), [B.6](#), and [B.7](#).

3.2.10

distance from mirror to object

distance from the mirror to an object being viewed by the driver

Note 1 to entry: See [Figure B.14](#).

Note 2 to entry: It is denoted as d_{object} and is measured in meters.

3.2.11

mirror radius of curvature

radius of the sphere that specifies the shape of a spherical mirror surface

Note 1 to entry: See [Figure 2](#).

Note 2 to entry: For convex spherical mirrors with the reflective layer on the convex surface, this value is positive.

Note 3 to entry: It is denoted as r_{mirror} and is measured in metres.

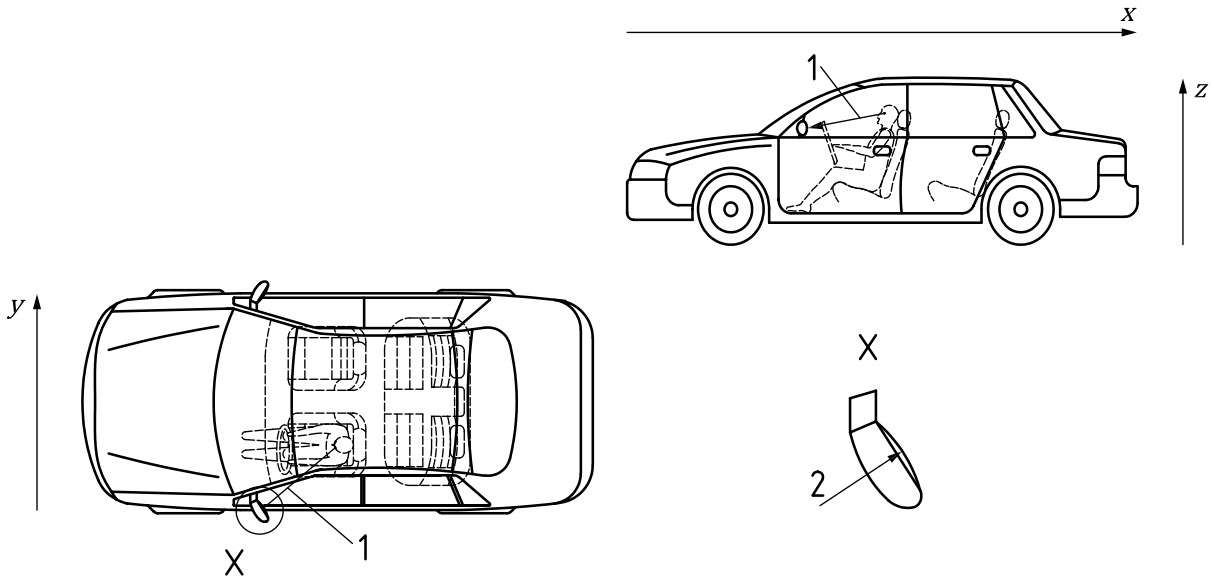

Key

- 1 a_{mirror}
- 2 r_{mirror}

Figure 2 — Mirror radius of curvature

3.2.12

mirror minimum allowed radius of curvature

minimum allowed value for r_{mirror} , as defined by the responsible national body

Note 1 to entry: It is denoted as $r_{mirror/min}$ and is measured in metres.

Note 2 to entry: The values given below are examples:

- for UN Regulation No. 46 class I spherical convex mirrors, this value is defined as $r_{mirror/min} = 1,2$ m;
- for UN Regulation No. 46 class II spherical convex mirrors, this value is defined as $r_{mirror/min} = 1,2$ m;
- for UN Regulation No. 46 class III spherical convex mirrors, this value is defined as $r_{mirror/min} = 1,2$ m;
- for UN Regulation No. 46 class IV spherical convex mirrors, this value is defined as $r_{mirror/min} = 0,3$ m;
- for main mirrors on cab-over-engine type trucks according to Article 44 of Japanese Safety Regulations for Road Vehicles, this value is defined as $r_{mirror/min} = 0,6$ m;
- for main mirrors on motor vehicles with a passenger capacity of 11 persons or more according to Article 44 of Japanese Safety Regulations for Road Vehicles, this value is defined as $r_{mirror/min} = 0,6$ m;
- for mirrors on the other vehicle category in Japan refer to Article 44 of Japanese Safety Regulations for Road Vehicles;
- FMVSS 111 only allows for plane mirrors where $r_{mirror/min}$ is infinite on the driver side; however, on the passenger side of the vehicle, FMVSS 111 defines a spherical convex mirror with a minimum radius of $r_{mirror/min} = 0,889$ m.

Note 3 to entry: According to Article 44 of Japanese Safety Regulations for Road Vehicles, main mirror means “Those mirrors used mainly for observing obstacles showing up around the rear portion on the left side of the vehicle”. See [Figures B.5](#), [B.6](#), and [B.7](#).

3.2.13
mirror angular size

angle under which the driver perceives the mirror

Note 1 to entry: See *mirror horizontal angular size* (3.2.14) and *mirror vertical angular size* (3.2.15) for details and differentiation between horizontal and vertical direction.

3.2.14
mirror horizontal angular size

angle between the lines from the ORP to the left and right edge (in y-direction) of the reflective mirror surface

Note 1 to entry: See [Figure 3](#).

Note 2 to entry: It is denoted as $\alpha'_{mirror/hor}$ and is measured in degrees.

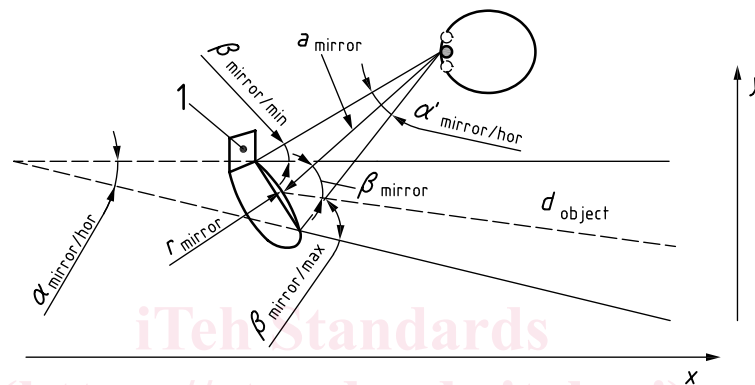

Key

1 mirror

Figure 3 — Mirror horizontal angular size (bird's eye view)

[ISO 16505:2019](https://standards.iteh.ai/ISO-16505:2019)

<https://standards.iteh.ai/catalog/standards/iso/fd6c00ff-d934-46a8-b135-bf15a145fe05/iso-16505-2019>

3.2.15
mirror vertical angular size

angle between the lines from the ORP to the top and bottom edge in (z-direction) of the reflective mirror surface

Note 1 to entry: See [Figure 4](#).

Note 2 to entry: It is denoted as $\alpha'_{mirror/ver}$ and is measured in degrees.

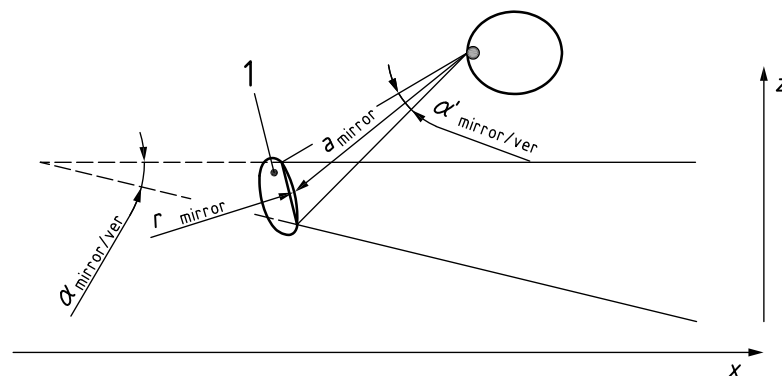

Key

1 mirror

Figure 4 — Mirror vertical angular size (side view)

3.2.16

field of view

space defined by all rays of light (lines from object points to the reflective mirror surface) that are still reflected into the driver's imaginary monocular eye point at the ORP

Note 1 to entry: This space can be approximated by a pyramid with its base lying in the y-z-plane.

3.2.17

horizontal field of view

angle between the leftmost and the rightmost ray of the field of view projected to the x-y-plane

Note 1 to entry: It is denoted as $\alpha_{mirror/hor}$ and is measured in degrees.

3.2.18

minimum horizontal field of view

minimum allowed value for $\alpha_{mirror/hor}$ as defined by the responsible national body

Note 1 to entry: It is denoted as $\alpha_{mirror/hor/min}$ and is measured in degrees.

Note 2 to entry: Information on $\alpha_{mirror/hor/min}$ for different mirror classes is given in [B.2.1](#).

3.2.19

vertical field of view

angle between the topmost and the bottommost ray of the field of view projected to the x-z-plane

Note 1 to entry: It is denoted as $\alpha_{mirror/ver}$ and is measured in degrees.

3.2.20

minimum vertical field of view

minimum allowed value for $\alpha_{mirror/ver}$ as defined by the responsible national body

Note 1 to entry: It is denoted as $\alpha_{mirror/ver/min}$ and is measured in degrees.

Note 2 to entry: Information on $\alpha_{mirror/ver/min}$ for different mirror classes is given in [B.2.2](#).

3.2.21

mirror magnification factor

relationship between the correct size of an object and its perceived size when seen through the mirror

Note 1 to entry: It is dependent on the distance from the ORP to the mirror a_{mirror} (see [3.2.2](#)), the radius of the mirror r_{mirror} (see [3.2.11](#)), the distance to the object d_{object} (see [3.2.10](#)), and the mirror viewing angle β_{mirror} (see [3.2.5](#)). It is denoted as M_{mirror} .

Note 2 to entry: For convex spherical rearview mirrors, the magnification factor is below 1, i.e. objects in a rearview mirror appear smaller than they really are. For plane mirrors with unit magnification, the magnification factor is equal to 1, i.e. there is no magnification.

Note 3 to entry: For a formula describing the magnification factor variation over the mirror, refer to [B.3](#).

3.2.22

mirror average magnification factor

average value for the magnification based on a mirror with minimum radius $r_{mirror/min}$ and maximum distance to the ORP $a_{mirror/max}$

Note 1 to entry: It is denoted as $M_{mirror/avg}$.

Note 2 to entry: It is derived as the average over the relevant range of viewing angles β_{mirror} at the horizontal centre line of the mirror and distances d_{object} .

Note 3 to entry: See *mirror average magnification factor (driver side)* ([3.2.23](#)) and *mirror average magnification factor (passenger side)* ([3.2.24](#)) for details and differentiation between driver and passenger side.