**Geotechnical investigation and
testing — Laboratory testing of soil —
Part 12:
Determination of liquid and plastic
limits**

iTeh STANDARD PREVIEW
*Reconnaissance et essais géotechniques — Essais de laboratoire sur
les sols —
(standards.iteh.ai)
Partie 12: Détermination des limites de liquidité et de plasticité*

[ISO 17892-12:2018](https://standards.iteh.ai/catalog/standards/sist/ca146182-6c1a-44ae-8289-2b2117c186e2/iso-17892-12-2018)

<https://standards.iteh.ai/catalog/standards/sist/ca146182-6c1a-44ae-8289-2b2117c186e2/iso-17892-12-2018>



iTeh STANDARD PREVIEW
(standards.iteh.ai)

ISO 17892-12:2018

<https://standards.iteh.ai/catalog/standards/sist/ca146182-6c1a-44ae-8289-2b2117c186e2/iso-17892-12-2018>



COPYRIGHT PROTECTED DOCUMENT

© ISO 2018

All rights reserved. Unless otherwise specified, or required in the context of its implementation, no part of this publication may be reproduced or utilized otherwise in any form or by any means, electronic or mechanical, including photocopying, or posting on the internet or an intranet, without prior written permission. Permission can be requested from either ISO at the address below or ISO's member body in the country of the requester.

ISO copyright office
CP 401 • Ch. de Blandonnet 8
CH-1214 Vernier, Geneva
Phone: +41 22 749 01 11
Fax: +41 22 749 09 47
Email: copyright@iso.org
Website: www.iso.org

Published in Switzerland

Contents

	Page
Foreword	iv
Introduction	v
1 Scope	1
2 Normative references	1
3 Terms and definitions	1
4 Apparatus	2
4.1 General.....	2
4.2 Fall cone method.....	3
4.3 Casagrande method.....	5
4.4 Plastic limit equipment.....	6
5 Test procedure	7
5.1 Choice of liquid limit method.....	7
5.2 Specimen preparation.....	7
5.3 Determination of liquid limit by the fall cone method.....	8
5.4 Determination of liquid limit by the Casagrande method.....	10
5.5 Determination of plastic limit.....	12
6 Test results	13
6.1 Proportion of sample smaller than 0,4 mm.....	13
6.2 Liquid limit by the fall cone method.....	13
6.3 Liquid limit by the Casagrande method.....	15
6.4 Plastic limit.....	15
6.5 Plasticity index.....	16
7 Test report	16
7.1 Mandatory reporting.....	16
7.2 Optional reporting.....	16
Annex A (normative) Calibration, maintenance and checks	18
Annex B (normative) Additional parameters	25
Bibliography	27

Foreword

ISO (the International Organization for Standardization) is a worldwide federation of national standards bodies (ISO member bodies). The work of preparing International Standards is normally carried out through ISO technical committees. Each member body interested in a subject for which a technical committee has been established has the right to be represented on that committee. International organizations, governmental and non-governmental, in liaison with ISO, also take part in the work. ISO collaborates closely with the International Electrotechnical Commission (IEC) on all matters of electrotechnical standardization.

The procedures used to develop this document and those intended for its further maintenance are described in the ISO/IEC Directives, Part 1. In particular the different approval criteria needed for the different types of ISO documents should be noted. This document was drafted in accordance with the editorial rules of the ISO/IEC Directives, Part 2 (see www.iso.org/directives).

Attention is drawn to the possibility that some of the elements of this document may be the subject of patent rights. ISO shall not be held responsible for identifying any or all such patent rights. Details of any patent rights identified during the development of the document will be in the Introduction and/or on the ISO list of patent declarations received (see www.iso.org/patents).

Any trade name used in this document is information given for the convenience of users and does not constitute an endorsement.

For an explanation on the voluntary nature of standards, the meaning of ISO specific terms and expressions related to conformity assessment, as well as information about ISO's adherence to the World Trade Organization (WTO) principles in the Technical Barriers to Trade (TBT) see the following URL: www.iso.org/iso/foreword.html. (standards.iteh.ai)

This document was prepared by the European Committee for Standardization (CEN) Technical Committee CEN/TC 341 *Geotechnical investigation and testing*, in collaboration with ISO Technical Committee TC 182, *Geotechnics*, in accordance with the Agreement on technical cooperation between ISO and CEN (Vienna Agreement). ISO 17892-12:2018
https://standards.iteh.ai/catalog/standards/sist/ca146182-6c1a-44ae-8389-2b2117c186e2/iso-17892-12-2018

This first edition of ISO 17892-12 cancels and replaces ISO/TS 17892-12:2004, which has been technically revised. It also incorporates ISO/TS 17892-12:2004/Cor.1:2006.

A list of all the parts in the ISO 17892 series can be found on the ISO website.

Introduction

This document covers areas in the international field of geotechnical engineering never previously standardised internationally. It is intended that this document presents broad good practice and significant differences with national documents is not anticipated. It is based on international practice (see Reference [1]).

iTeh STANDARD PREVIEW (standards.iteh.ai)

[ISO 17892-12:2018](https://standards.iteh.ai/catalog/standards/sist/ca146182-6c1a-44ae-8289-2b2117c186e2/iso-17892-12-2018)

<https://standards.iteh.ai/catalog/standards/sist/ca146182-6c1a-44ae-8289-2b2117c186e2/iso-17892-12-2018>

iTeh STANDARD PREVIEW
(standards.iteh.ai)

ISO 17892-12:2018

<https://standards.iteh.ai/catalog/standards/sist/ca146182-6c1a-44ae-8289-2b2117c186e2/iso-17892-12-2018>

Geotechnical investigation and testing — Laboratory testing of soil —

Part 12: Determination of liquid and plastic limits

1 Scope

This document specifies methods for the determination of the liquid and plastic limits of a soil. These comprise two of the Atterberg limits for soils.

The liquid limit is the water content at which a soil changes from the liquid to the plastic state.

This document describes the determination of the liquid limit of a specimen of natural soil, or of a specimen of soil from which material larger than about 0,4 mm has been removed. This document describes two methods: the fall cone method and the Casagrande method.

NOTE The fall cone method in this document should not be confused with that of ISO 17892-6.

The plastic limit of a soil is the water content at which a soil ceases to be plastic when dried further.

The determination of the plastic limit is normally made in conjunction with the determination of the liquid limit. It is recognized that the results of the test are subject to the judgement of the operator, and that some variability in results will occur.

ISO 17892-12:2018

[https://standards.iteh.ai/catalog/standards/sist/ca146182-6c1a-44ae-8289-](https://standards.iteh.ai/catalog/standards/sist/ca146182-6c1a-44ae-8289-2b2117c186e2/iso-17892-12-2018)

[2b2117c186e2/iso-17892-12-2018](https://standards.iteh.ai/catalog/standards/sist/ca146182-6c1a-44ae-8289-2b2117c186e2/iso-17892-12-2018)

2 Normative references

The following documents are referred to in the text in such a way that some or all of their content constitutes requirements of this document. For dated references, only the edition cited applies. For undated references, the latest edition of the referenced document (including any amendments) applies.

ISO 3310-1, *Test sieves — Technical requirements and testing — Part 1: Test sieves of metal wire cloth*

ISO 14688-1, *Geotechnical investigation and testing — Identification and classification of soil — Part 1: Identification and description*

ISO 17892-1, *Geotechnical investigation and testing — Laboratory testing of soil — Part 1: Determination of water content*

3 Terms and definitions

For the purposes of this document, the following terms and definitions apply. ISO and IEC maintain terminological databases for use in standardization at the following addresses:

— IEC Electropedia: available at <https://www.electropedia.org/>

— ISO Online browsing platform: available at <https://www.iso.org/obp>

3.1

liquid limit

w_L

water content at which a soil passes from the liquid to the plastic state, as determined by the liquid limit test

**3.2
plastic limit**

w_p
water content at which a specimen ceases to be plastic when dried further, as determined by the plastic limit test

**3.3
plasticity index**

I_p
numerical difference between the liquid limit and the plastic limit of a soil

**3.4
non plastic soil**
soil which has a plasticity index of zero or one for which the plastic limit cannot be determined

4 Apparatus

4.1 General

See also [Annex A](#) for more manufacturing tolerances (where appropriate), calibration, maintenance and checks on the equipment.

4.1.1 Balance.

The balance shall have an accuracy of 0,01 g or 0,1 % of the weighed mass whichever value is the greater.

4.1.2 Test specimen containers.

Test specimen containers shall be made of a material that does not change mass as a result of repeated drying cycles. Glass, porcelain and corrosion-resistant metals have been found to be suitable. Containers shall have a capacity large enough to hold the mass of sample to be dried without spillage, but should not be so large that the mass of the empty container is significantly in excess of that of the specimen. Containers used for plastic limit determinations shall have close fitting lids.

4.1.3 Water.

Water should be distilled, de-ionized or demineralized. Where distilled is referred to in this document, the terms are interchangeable.

4.1.4 Ancillary apparatus.

4.1.4.1 Spatulas.

4.1.4.2 Spray bottle (preferably of plastic).

4.1.4.3 Evaporating dishes.

4.1.4.4 Sieves complying with ISO 3310-1.

4.1.4.5 Flat mixing plate, for example glass.

4.1.4.6 Metal straightedge about 100 mm long.

4.2 Fall cone method

4.2.1 Fall cone apparatus.

4.2.1.1 The fall cone apparatus is shown schematically in [Figure 1](#). It shall permit the cone to be held firmly initially and to be released instantaneously to fall freely in a vertical direction into the soil specimen.

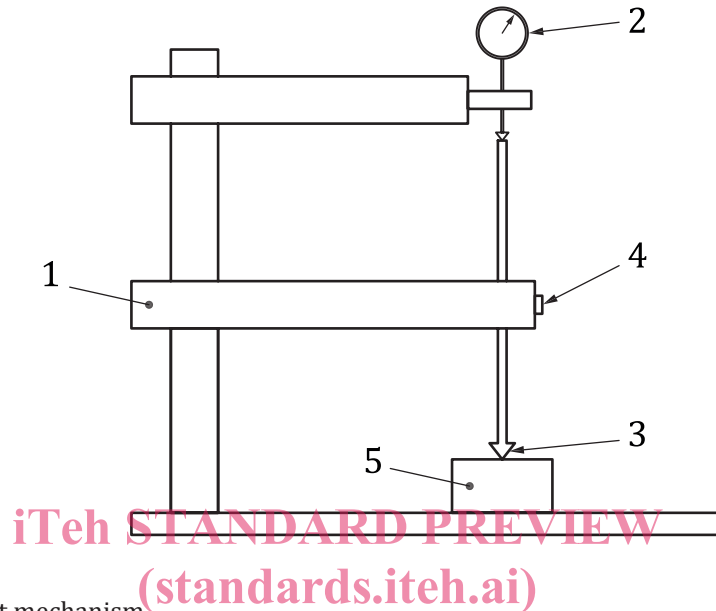

Key

- 1 vertical adjustment mechanism
 - 2 penetration measurement device
 - 3 fall cone
 - 4 lock/release button
 - 5 specimen cup
- <https://standards.iteh.ai/catalog/standards/sist/ca146182-6c1a-44ae-8289-2b2117c186e2/iso-17892-12-2018>

Figure 1 — Schematic of a fall cone apparatus

4.2.1.2 The fall cone apparatus shall have a vertical adjustment mechanism which allows the cone to be raised or lowered and adjusted so that the tip of the cone just touches the surface of the specimen before the cone is released.

4.2.1.3 The fall cone apparatus shall be equipped with a method of measuring the penetration of the cone into the specimen after release to a resolution of 0,1 mm (or better), within the range 5 mm to 20 mm if the 60 g/60° cone is used, or within the range 10 mm to 30 mm if the 80 g/30° cone is used.

4.2.2 Cones.

4.2.2.1 A typical cone is shown schematically in Figure 2.

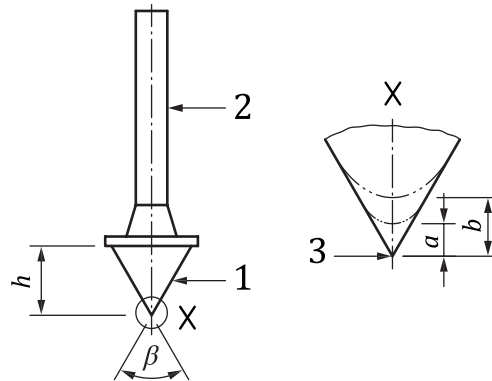

Key

- 1 cone
- 2 shaft
- 3 cone tip
- a deviation from the geometrical tip at manufacturing
- b maximum tip wear
- h height of the conical tip
- β tip angle

iTeh STANDARD PREVIEW
(standards.iteh.ai)

Figure 2 — Example of liquid limit fall cone penetrometer (60° cone)

ISO 17892-12:2018

<https://standards.iteh.ai/catalog/standards/sist/ca146182-6c1a-44ae-8289-7d186266d182/iso-17892-12:2018>

4.2.2.2 Either a 60 g/60° cone or a 80 g/30° cone complying with the requirements of Table 1 may be used as it has been shown that both cones give essentially the same value for the liquid limit. Other cone devices may be adopted provided they can be shown to give comparable results to those obtained from the tests described herein.

Table 1 — Set of fall cones — Typical manufacturing specifications for masses and dimensions

Mass of cone plus shaft	g	60 ± 0,06	80 ± 0,08
Tip angle β	°	60 ± 0,2	30 ± 0,2
Height of the cone tip h	mm	≥20	≥30
The deviation a from the geometrical tip at manufacturing	mm	<0,1	<0,1

4.2.2.3 The cone shall be manufactured of or coated with a corrosion resistant material such as stainless steel or chromium, and should have smooth polished surfaces with an average roughness Ra of less than 0,8 μm as a manufacturing specification. The cone surface has to remain smooth with use, and should be replaced if the smooth surface is noticeably damaged.

4.2.2.4 The maximum wear b shall be less than 0,3 mm (see Figure 2).

4.2.3 Sample cup.

The sample cup shall be made of non-corrodible and rigid material, spherical or cylindrical in shape. If cylindrical, it shall have a base parallel to the rim with a diameter of at least 50 mm and a depth of at least 25 mm if the 60 g/60° cone is used and a depth of at least 40 mm if the 80 g/30° cone is used.

4.2.4 Timing device.

A clock or stop-watch, or similar, capable of being read to the nearest 1 s.

4.3 Casagrande method

4.3.1 Casagrande apparatus.

The Casagrande apparatus is shown schematically in [Figure 3](#). The apparatus consists of a specimen cup which is raised by a cam and then dropped a specified distance onto a base. The device may be operated by either a hand crank or electric motor. Dimensions, manufacturing specifications and tolerances are included in [Annex A](#). A Casagrande apparatus and grooving tool in accordance with other specifications may be adopted provided it can be shown to give comparable results.

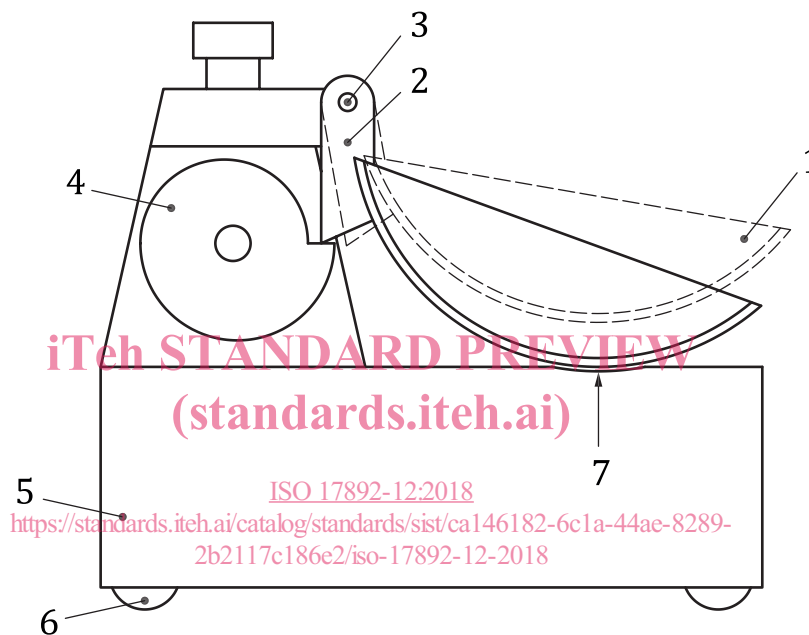

Key

- 1 specimen cup (= bowl)
- 2 hanger
- 3 carriage with pin
- 4 cam (turned by handle or motor)
- 5 base
- 6 rubber feet
- 7 point of contact

Figure 3 — Schematic of the Casagrande apparatus

4.3.2 Base and rubber feet.

The base and feet shall be made of rubber complying with the requirements of [Table 2](#). The feet supporting the base, are designed to provide isolation of the base from the work surface.

Table 2 — Base and feet — Rubber requirements

Hardness of the feet	Hardness of the base	Resilience of the base
Shore A value between 62 and 65	Shore D value of at least 80	Resilience (rebound value) between $S = 0,80$ and $S = 0,90$

Measurement of hardness (Shore A and Shore D) and resilience S is defined in [A.3.7.5](#).

4.3.3 Specimen Cup.

The specimen cup should be made of brass or stainless steel. The shape of the cup shall be a segment of a sphere. Dimensions, manufacturing specifications and tolerances are included in [Annex A](#).

The cup should not be polished. The surface has to remain smooth with use, and should be replaced if the smooth surface is noticeably damaged.

4.3.4 Cam.

The cam shall raise the cup smoothly and continuously to its maximum height, by increasing the radius of the cam over at least 180° of cam rotation. The final portion of the cam shall be shaped so that the cup does not develop an upward or downward velocity when the cam follower leaves the cam. A logarithmic spiral design has been found to be satisfactory.

4.3.5 Carriage.

The carriage is constructed in a way that allows convenient but secure adjustment of the 10 mm height-of-drop of the cup.

4.3.6 Motor drive (optional).

The apparatus may be equipped with a motor to turn the cam and if used shall operate at $2 \pm 0,25$ revolutions per second. The motor shall be isolated from the rest of the device by rubber mounts or in some other way that prevents vibration from the motor being transmitted to the rest of the apparatus.

4.3.7 Grooving tool.

ISO 17892-12:2018

<https://standards.iteh.ai/catalog/standards/sist/ca146182-6c1a-44ae-8289-2b217c16cc53/iso-17892-12-2018>

A flat or curved tool made of plastic or non-corroding metal. The grooving tool shall have a bevelled tip (see [Annex A](#)). The design of the tool may vary as long as the essential dimensions are maintained. The tool may, but need not incorporate the gauge for adjusting the height-of-drop of the liquid limit device.

4.4 Plastic limit equipment

4.4.1 Mixing plate.

The mixing plate shall be flat, clean and smooth, and should be free from significant scratches which affect the behaviour during rolling of the threads. A glass plate of about 10 mm thick and 300 mm square has been found to be convenient.

4.4.2 Rod or gauge.

Either a rod with a diameter between 3 mm and 3,5 mm, or a gauge with an opening of the same size, shall be used.