



Designation: C1698 – 09

Standard Test Method for Autogenous Strain of Cement Paste and Mortar¹

This standard is issued under the fixed designation C1698; the number immediately following the designation indicates the year of original adoption or, in the case of revision, the year of last revision. A number in parentheses indicates the year of last reapproval. A superscript epsilon (ϵ) indicates an editorial change since the last revision or reapproval.

1. Scope

1.1 This test method measures the bulk strain of a sealed cement paste or mortar specimen, including those containing admixtures, various supplementary cementitious materials (SCM), and other fine materials, at constant temperature and not subjected to external forces, from the time of final setting until a specified age. This strain is known as *autogenous strain*. Autogenous strain is most significant in concrete with low water-cementitious materials ratio (w/cm) (See [Note 1](#)).

NOTE 1—A low water-cementitious materials ratio (w/cm) can be considered to be a water to cement ratio of 0.40 or lower for this test.

1.2 The values stated in SI units are to be regarded as standard. No other units of measurement are included in this standard.

1.3 *This standard does not purport to address all of the safety concerns, if any, associated with its use. It is the responsibility of the user of this standard to establish appropriate safety and health practices and determine the applicability of regulatory limitations prior to use. (Warning—Fresh hydraulic cementitious mixtures are caustic and may cause chemical burns to skin and tissue upon prolonged exposure.²)*

2. Referenced Documents

2.1 *ASTM Standards*:³

[C125 Terminology Relating to Concrete and Concrete Aggregates](#)

[C157/C157M Test Method for Length Change of Hardened Hydraulic-Cement Mortar and Concrete](#)

[C191 Test Methods for Time of Setting of Hydraulic Cement by Vicat Needle](#)

[C192/C192M Practice for Making and Curing Concrete Test Specimens in the Laboratory](#)

[C219 Terminology Relating to Hydraulic Cement](#)

[C305 Practice for Mechanical Mixing of Hydraulic Cement Pastes and Mortars of Plastic Consistency](#)

[C403/C403M Test Method for Time of Setting of Concrete Mixtures by Penetration Resistance](#)

[C1005 Specification for Reference Masses and Devices for Determining Mass and Volume for Use in the Physical Testing of Hydraulic Cements](#)

2.2 *API Specification*⁴

[RP 10B-2/ISO 10426-2 Recommended Practice for Testing Well Cements](#)

3. Terminology

3.1 *Definitions*:

3.1.1 For definitions of terms used in this test method, refer to Terminologies [C125](#) and [C219](#).

3.2 *Definitions of Terms Specific to This Standard*:

3.2.1 *autogenous strain, n*—the bulk strain of a sealed specimen of a cementitious mixture, not subjected to external forces and under constant temperature, measured from the time of final setting until a specified age; negative strain corresponds to shrinkage and positive strain corresponds to expansion.

4. Summary of Test Method

4.1 A specimen of freshly mixed paste or mortar is prepared using a corrugated mold that offers little resistance to length change of the specimen. The mold is sealed to prevent moisture loss and the specimen is stored at constant temperature. Starting at the time of final setting, the length of the specimen is measured using a dilatometer. The change in length is recorded at regular time intervals until the designated age. The change in length and original length of the specimen are used to compute the autogenous strain.

5. Significance and Use

5.1 Autogenous strain is the self-created bulk strain of cement paste, mortar, or concrete during hardening at constant temperature. In conventional concrete, autogenous shrinkage strain is generally negligible, but in concrete with low water-cementitious materials ratio (w/cm) or with silica fume it may

¹ This test method is under the jurisdiction of ASTM Committee C09 on Concrete and Concrete Aggregates and is the direct responsibility of Subcommittee C09.68 on Volume Change.

Current edition approved Oct. 1, 2009. Published November 2009. DOI: 10.1520/C1698-09.

² Section on Safety Precautions, Manual of Aggregate and Concrete Testing, *Annual Book of ASTM Standards*, Vol 04.02.

³ For referenced ASTM standards, visit the ASTM website, www.astm.org, or contact ASTM Customer Service at service@astm.org. For *Annual Book of ASTM Standards* volume information, refer to the standard's Document Summary page on the ASTM website.

⁴ Available from American Petroleum Institute (API), 1220 L. St., NW, Washington, DC 20005-4070, <http://www.api.org>.

be considerable (1).⁵ Restraint of the autogenous strain by aggregates or adjoining structural members may result in formation of micro and macro cracks that impair strength, durability and aesthetics. Cracks may also be a problem with regard to hygienic cleaning of surfaces.

5.2 An accurate measurement of the autogenous strain of cementitious mixtures with low w/cm is important for evaluating the risk of early-age cracking of concrete structures. Measurements of autogenous strain have been carried out using either volumetric or linear methods. Both methods may show evidence of significant artifacts (1); therefore, results of the two methods may disagree considerably if not carried out properly.

5.3 A sealed, flexible corrugated mold system (2) combines the advantages of linear and volumetric measurement of autogenous strain, while avoiding most of their disadvantages. The mold effectively prevents moisture loss and minimizes restraint to volume change during hardening. Moreover, results obtained with the corrugated mold system agree with those from the volumetric method, once some artifacts, in particular water absorption through the membrane used to contain the test specimen, have been eliminated in the latter (3,4). The corrugated mold system is easier to use and shows better repeatability than the volumetric technique (3,4). Measurements with the corrugated mold system are in good agreement with unrestrained length change measurements obtained using Test Method C157/C157M with sealed specimens (5); however, Test Method C157/C157M does not allow measurement of the shrinkage occurring before 24 h (5).

5.4 This test method can be used to evaluate the effects of cementitious materials, admixtures, and mixture proportions on autogenous shrinkage strain of paste or mortar specimens.

⁵ The boldface numbers in parentheses refer to a list of references at the end of this standard.

5.5 The autogenous shrinkage strain of mortar specimens will be less than that of paste specimens for the same w/cm . The autogenous shrinkage strain of concrete will be less than that of mortar for the same w/cm . The nominal maximum aggregate size for mortar used in this test method is 4.75 mm.

6. Apparatus

6.1 The apparatus to measure autogenous strain is composed of a corrugated mold with two end plugs, a dilatometer bench, a length measuring gauge, and a reference bar (see Fig. 1).

6.2 *Molds*—The molds consist of corrugated plastic tubes, having a length of 420 ± 5 mm and an outer diameter of 29 ± 0.5 mm (see Note 2). The plastic tubes are made of 0.5 ± 0.2-mm thick low-density polyethylene (PE) and have triangular-shaped corrugations in order to minimize restraint in the longitudinal direction (see Fig. 2). The distance between corrugations is 5.8 ± 0.2 mm. The mold is tightly closed with two tapered end plugs having a length of 19 ± 0.5 mm. The diameter of the plastic end plugs tapers from 21 ± 0.1 mm to 22.4 ± 0.1 mm (see Fig. 3).

NOTE 2—The small diameter of the molds limits the temperature differences that may arise during hydration of the cementitious materials. Typical maximum temperature increase in the center of the test specimen, due to heat of hydration of cement paste or mortar has been determined to be 2 °C. The maximum longitudinal restraint stress exerted by the molds has been determined to be 0.001 MPa (6).

6.3 *Dilatometer Bench*—The dilatometer bench consists of three stainless steel rods with a diameter of 20 ± 1.0 mm and two stainless steel end plates. Technical drawings of a suitable dilatometer bench are shown in Fig. 4. During measurement, the test specimen is positioned horizontally and is supported longitudinally by the two upper rods.

6.4 *Length Measuring Gauge*—A gauge measures length changes at one end of the specimen. The measuring range of the gauge shall be at least 10 mm and the resolution shall be at

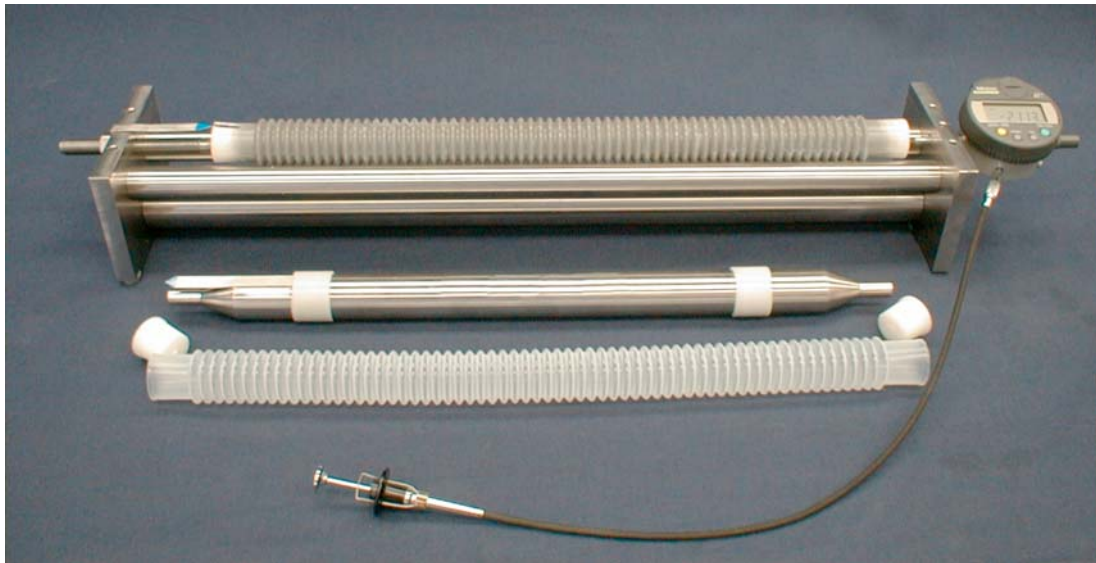

NOTE 1—In the foreground a corrugated PE-mold with two specially shaped end plugs and a 425 mm reference bar. In the background the dilatometer bench with a test specimen placed for length measurement. To the right a digital length gauge with remote control.

FIG. 1 A Suitable Dilatometer Bench with Accessories



FIG. 2 Corrugated Polyethylene Mold

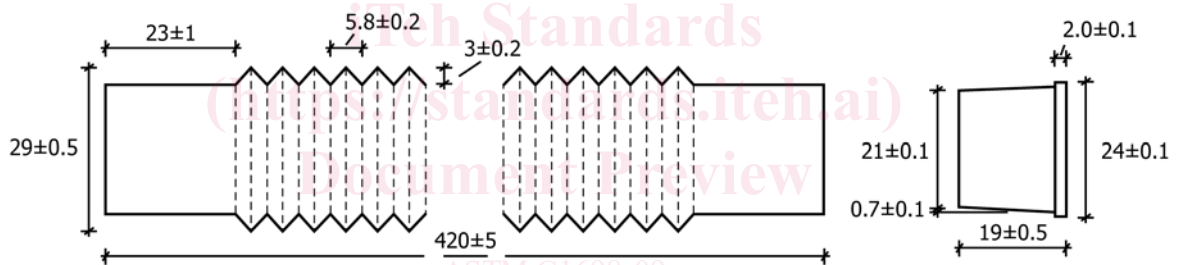

NOTE 1—Plastic Tube Wall Thickness 0.5 ± 0.2 mm.

FIG. 3 Outer Dimensions (mm) of Corrugated Low-Density Polyethylene Mold and End Plug

least 0.0025 mm, corresponding to a resolution of about 6 $\mu\text{m}/\text{m}$ for the calculated strain.

6.5 *Reference Bar*—Measurements in the dilatometer are performed relative to the length of the reference bar. The bar is made of Invar with a length of 425 ± 0.5 mm and a diameter of 20 ± 1.0 , tapering to 10 ± 1.0 mm at both ends as shown in Fig. 5. The actual length of the reference bar shall be marked permanently on the bar to the nearest 0.01 mm. Two plastic rings with an external diameter 30 ± 0.5 mm are mounted on the reference bar, as shown in Fig. 1.

6.6 *Reference Masses and Devices for Determining Mass and Volume* shall conform to the requirements of Specification C1005.

6.7 *Support Tube* used to support the corrugated mold during specimen fabrication. The support tube has a length of 400 ± 5 mm and an inside diameter of 32 ± 1 mm (see Fig. 6). The tube is attached to a base that can be fixed to a vibrating table.

6.8 *Vibrating Table* as described in Practice C192/C192M.

6.9 *Tamping Rod* for consolidation of the paste or mortar. It shall be made of a rigid, non-absorptive material that does not react with the cementitious mixture. The length of the rod shall be at least 500 mm and the diameter shall be 6 ± 1 mm. The ends may be flat or hemispherical.

7. Procedure

7.1 *Number of Specimens*—Three replicate specimens shall be tested for each cement paste or mortar (see Note 3).

7.1.1 *Mixing*—Mix cement pastes and mortars according to Practice C305. Record the time when the cementitious materials are added to the water.

7.1.2 *Mixing Apparatus*

7.1.2.1 *Mortar Preparation*—The mixer shall comply with the sequence in Practice C305.

7.1.2.2 *Paste Preparation*—A high shear blender,⁶ or similar variable speed blender capable of maintaining a no-load speed of at least 15 000 r/min, with optional cooling device. A

⁶ Mixing devices described in API Specification RP 10B-2/ISO 10426-2.

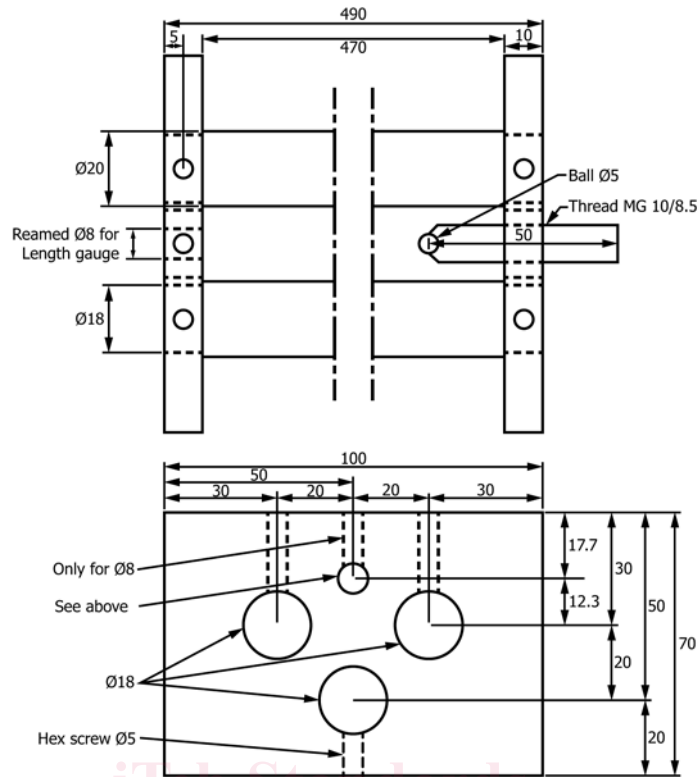

NOTE 1—All dimensions are in mm (tolerance $\pm 0.5\%$).

FIG. 4 Technical Drawing of the Dilatometer Bench Shown in Fig. 1
Top: Plan View. Bottom: Elevation View of End Plate

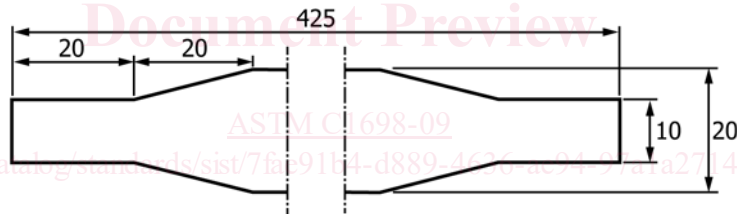

NOTE 1—All dimensions are in mm and tolerances given in the text.

FIG. 5 Technical Drawing of the Reference Bar Shown in Fig. 1

hand-held household mixer capable of mixing paste at not less than 400 r/min or other mixers for paste or mortar preparation are also permitted.

NOTE 3—About 185 mL of cement paste or mortar are needed to fill each corrugated mold. For a paste with a water-cement ratio of 0.4, this corresponds to approximately 360 g of paste.

7.2 Filling and Closing of Molds—Clamp the mounting base of the support tube to a vibrating table. Measure the lengths of the plugs to be used for each specimen. Place a plug into one end of the mold, and position the mold, with the closed end down, inside the support tube. If the cementitious mixture is pourable, slowly pour the mixture into the corrugated mold with the vibrating table turned on (see Fig. 7). For a semi-fluid mixture, fill the mold in four equal layers and compact each layer 5 times with the tamping rod before each subsequent layer is cast. The rod shall just penetrate the underlying layer. For a stiff mixture, hand prepare rolled sections of the

cementitious mixture, drop them into the mold, and consolidate with the tamping rod. To ensure that the cast specimens have approximately the same length, do not stretch or compress the corrugated mold during filling. For fluid mixtures, the corrugated mold shall be held only by the support tube during casting. For semi-fluid and stiff mixtures, manually maintain the initial length of the mold during compaction. Fill the mold to approximately 15 mm below the top end of the mold to allow room for the top end plug. Before mounting the top end plug, gently compress the corrugated mold to bring the cement paste or mortar in contact with the end plug. Mount the end plug during relief of the compression of the corrugated mold. Use a screwing motion of the end plug to ease the mounting operation. Immediately after casting, carefully wipe the surface of the corrugated mold with a dry cloth to remove any cement paste, mortar, or water.