



Designation: G202 – 09

Standard Test Method for Using Atmospheric Pressure Rotating Cage¹

This standard is issued under the fixed designation G202; the number immediately following the designation indicates the year of original adoption or, in the case of revision, the year of last revision. A number in parentheses indicates the year of last reappraisal. A superscript epsilon (ϵ) indicates an editorial change since the last revision or reappraisal.

1. Scope

1.1 This test method covers a generally accepted procedure to conduct the rotating cage (RC) experiment under atmospheric pressure.

1.2 The values stated in SI units are to be regarded as the standard. The values given in parentheses are for information only.

1.3 *This standard does not purport to address all of the safety concerns, if any, associated with its use. It is the responsibility of the user of this standard to establish appropriate safety and health practices and determine the applicability of regulatory limitations prior to use.*

2. Referenced Documents

2.1 *ASTM Standards:*²

D1141 Practice for the Preparation of Substitute Ocean Water

D1193 Specification for Reagent Water

D1293 Test Methods for pH of Water

G1 Practice for Preparing, Cleaning, and Evaluating Corrosion Test Specimens

G16 Guide for Applying Statistics to Analysis of Corrosion Data

G31 Practice for Laboratory Immersion Corrosion Testing of Metals

G46 Guide for Examination and Evaluation of Pitting Corrosion

G170 Guide for Evaluating and Qualifying Oilfield and Refinery Corrosion Inhibitors in the Laboratory

G184 Practice for Evaluating and Qualifying Oil Field and Refinery Corrosion Inhibitors Using Rotating Cage

3. Significance and Use

3.1 The rotating cage (RC) test system is relatively inexpensive system that uses flat specimens to assess the effect of

¹ This test method is under the jurisdiction of ASTM Committee G01 on Corrosion of Metals and is the direct responsibility of Subcommittee G01.05 on Laboratory Corrosion Tests.

Current edition approved Oct. 1, 2009. Published November 2009. DOI: 10.1520/G0202-09.

² For referenced ASTM standards, visit the ASTM website, www.astm.org, or contact ASTM Customer Service at service@astm.org. For *Annual Book of ASTM Standards* volume information, refer to the standard's Document Summary page on the ASTM website.

flow across a specimen on the corrosion that occurs on the specimen. This system does not produce an easily characterized flow system but it is adjustable over a wide range of flow rates and uses readily available specimens. (1-11).³

3.2 The RC method can be used to evaluate either corrosion inhibitors or materials or both. Guide G184 describes the procedure to use rotating cage to evaluate corrosion inhibitors.

3.3 In this test method, a general procedure is presented to obtain reproducible results using atmospheric pressure RC described in Guide G184 to simulate the effects of different types of coupon materials, inhibitor concentrations, oil, gas and solution compositions, and flow. Oil field fluids may often contain sand; however, this test method does not cover erosive effects that occur when sand is present.

4. Apparatus

4.1 Fig. 1 shows the schematic diagram of the atmospheric pressure RC system. The vessel is manufactured from acrylic. At the bottom of the container, a polytetrafluoroethylene (PTFE) base is snugly fitted. Vessel made from other materials may be used provided it is first ascertained that they are compatible with the solutions and gases to be used in the test. At the center of the base, a hole is drilled, into which the lower end of the rotating shaft is placed. This arrangement stabilizes the rotating shaft and the coupons. The length of the rotating shaft between the top and bottom covers is 40 cm (15.7 in.). The rotating cage is attached to the shaft in such a way that the top of the cage is 30 cm (11.8 in.) from the bottom cover.

4.2 Eight identical coupons machined from the same material (each of length 75 mm, width 19 mm, thickness 3 mm, and surface area 34.14 cm²) are supported between two PTFE disks (of 80-mm diameter) mounted 75 mm apart on the stirring rod (Fig. 2). Holes (diameter 10 mm) about 15 mm away from the center are drilled in the top and bottom PTFE plates of the cage to increase the turbulence on the inside surface of the coupon (Fig. 3). This experimental setup can be used at rotation speeds up to 1000 r/min.

4.3 The rotation speed is selected based on field operating conditions. To determine the rotation speed the wall shear

³ The boldface numbers in parentheses refer to a list of references at the end of this standard.

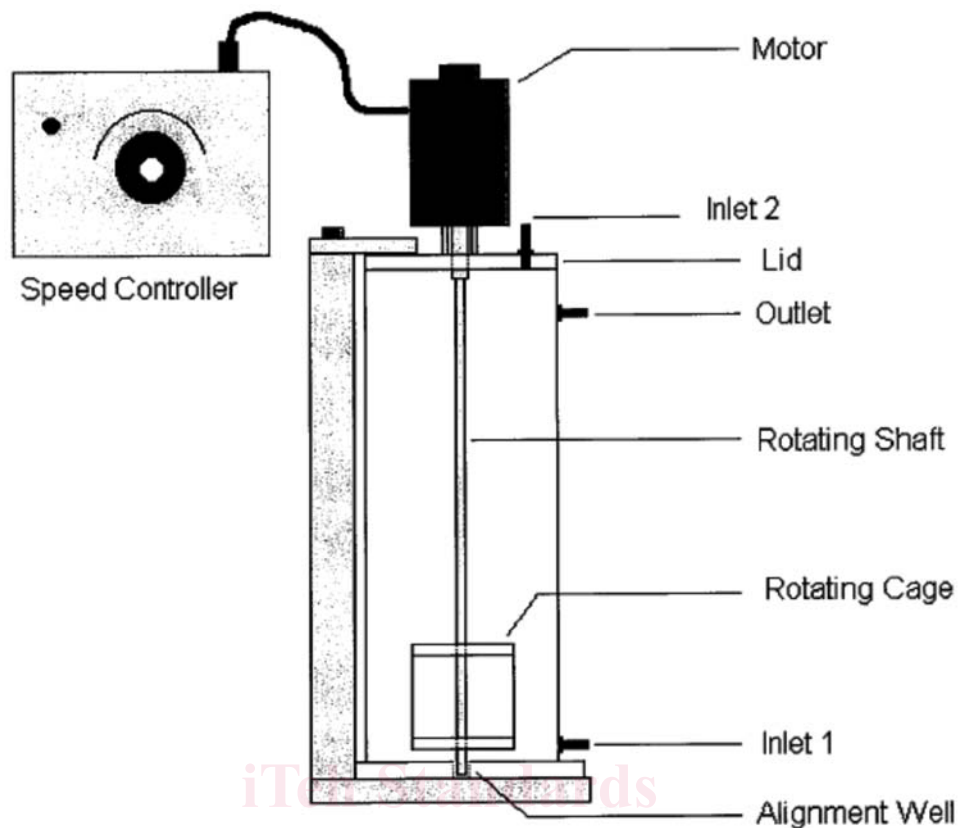

FIG. 1 Schematic Diagram of Rotating Cage



FIG. 2 Photo of Rotating Cage Containing Coupons—Gaps (Typically 0.85 ± 0.01 cm) between the Coupons Introduce Localized Turbulence

stress of the field is first determined. Based on the wall shear stress the rotation speed is calculated. The relationship between rotation speed and wall shear stress is described in Guide

G170. If the field operating conditions are unknown the rotation speed shall be 500 r/min.

4.4 Flow patterns inside the RC depend on the rotation speed, the volume of the container, volume of the solution, and the nature of the solution used. The flow patterns are described in Guide G170.

4.5 Volume of solution to the surface area of the specimen has some effect on the corrosion rate. The minimum solution volume (cm^3) to metal surface area (cm^2) is not less than $14 \text{ cm}^3/\text{cm}^2$ (10).

5. Reagents

5.1 *Purity of Reagents*—Reagent-grade chemicals shall be used in all tests. Unless otherwise indicated, it is intended that all reagents conform to the specifications of the Committee on Analytical Reagents of the American Chemical Society where such specifications are available.⁴ Other grades may be used, provided it is first ascertained that the reagent is of sufficiently high purity to permit its use without lessening the accuracy of the experiment.

5.2 The composition of the solution shall be determined and reported. Alternatively, standard brine (such as in Practice

⁴ *Reagent Chemicals, American Chemical Society Specifications*, American Chemical Society, Washington, DC. For Suggestions on the testing of reagents not listed by the American Chemical Society, see *Annual Standards for Laboratory Chemicals*, BDH Ltd., Poole, Dorset, U.K., and the *United States Pharmacopeia and National Formulary*, U.S. Pharmacopeial Convention, Inc. (USPC), Rockville, MD.

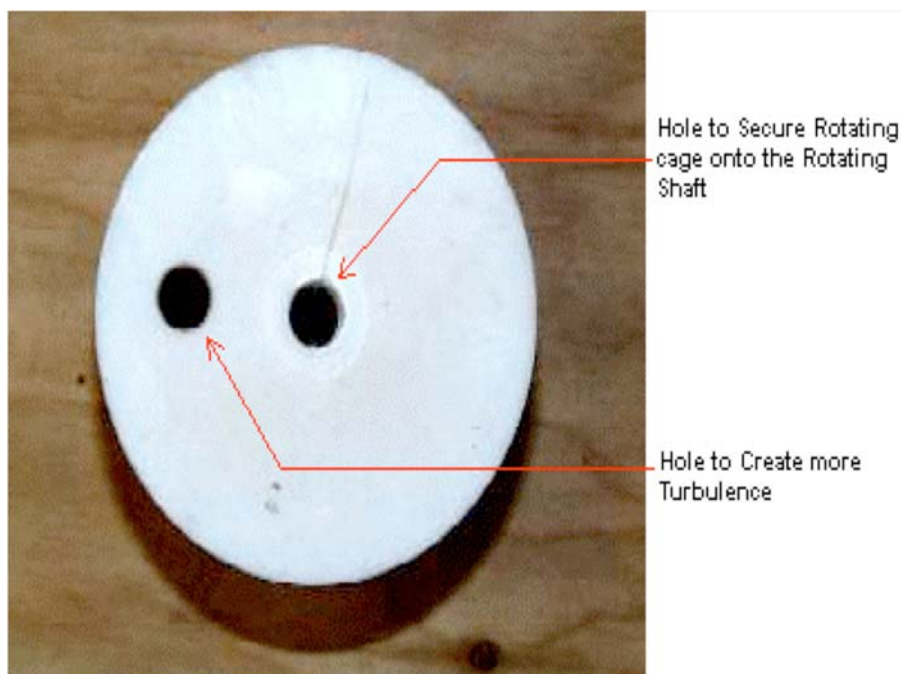

FIG. 3 Photo of Rotating Cage (Top View)—Holes (Typically 1.0 cm Diameter, about 1.5 cm from the Center) Introduce Localized Turbulence

D1141) shall be used. The solutions shall be prepared using reagents (in accordance with 5.1) and deionized water (in accordance with Specification D1193).

5.3 The solution shall be deoxygenated by passing nitrogen or any other inert gas to reduce the oxygen content. The solution shall be kept under deoxygenated conditions. The oxygen concentration in solution depends on the quality of gases used to purge the solution. The oxygen content of nitrogen or the inert gas shall be less than 10 ppm by volume. Any leaks through the vessel, tubing, and joints shall be avoided.

5.4 **Warning**—Hydrogen sulphide (H₂S) and carbon dioxide (CO₂) are corrosive gases. H₂S is poisonous and shall not be released to the atmosphere. The appropriate composition of gas can be obtained by mixing H₂S and CO₂ streams from the standard laboratory gas supply. Nitrogen or any other inert gas can be used as a diluent to obtain the required composition of corrosive gases. The oxygen content of these gases shall not exceed 10 ppm by volume.

5.5 To ensure proper deoxygenation and presaturation of the solution at least 1.5 L of purge gas/L of test solution shall be bubbled through the test solution at a rate no less than 25 mL/min.

NOTE 1—Bubbling gas using a tube of internal diameter (0.635 cm or ¼ in.) at a rate of 4 bubbles/s for 1 h corresponds to passing 1.447 L of gas, assuming that the bubbles are spherical in shape with a diameter of ¼ inch (0.635 cm) and a volume of 0.1005 cm³.

5.6 The solution pH before and after testing shall be measured, recorded, and reported (in accordance with Test Methods D1293).

6. Test Specimen

6.1 Methods for preparing specimens for tests and removing specimens after the test are described in Practice G1. Standard laboratory glassware shall be used for weighing and measuring reagent volumes.

6.2 The coupon shall have the same metallographic structure as that used in the service components. The coupons shall be ground to a surface finish of 150 grit. The grinding shall produce a reproducible surface finish with no rust deposits, pits, or deep scratches. All sharp edges on the coupon shall be ground. All loose dirt particles shall be removed.

6.3 The coupons are rinsed with distilled water, degreased by immersing in acetone (or any suitable alcohol), ultrasonically cleaned for 1 min, and dried. The surface of the specimens shall not be touched with bare hands. The specimens are weighed to the nearest 0.1 mg, the dimensions are measured to the nearest 0.1 mm, and the surface areas are calculated.

6.4 Freshly prepared specimens are installed in the rotating cage holder. If the test is not commenced within 4 h, the prepared coupons shall be stored in a desiccator to avoid pre-rusting.