INTERNATIONAL STANDARD



2372

INTERNATIONAL ORGANIZATION FOR STANDARDIZATION • МЕЖДУНАРОДНАЯ ОРГАНИЗАЦИЯ ПО СТАНДАРТИЗАЦИИ • ORGANISATION INTERNATIONALE DE NORMALISATION

Mechanical vibration of machines with operating speeds from 10 to 200 rev/s — Basis for specifying evaluation standards

Vibrations mécaniques des machines ayant une vitesse de fonctionnement comprise entre 10 et 200 tr/s — Base pour l'élaboration des normes d'évaluation

First edition — 1974-11-01

ITeH STANDARD PREVIEW
(standards.iteh.ai)

[ISO 2372:1974](https://standards.iteh.ai/catalog/standards/sist/7ca26d67-cfe9-4fbc-afe4-c1d4bcab2209/iso-2372-1974)

<https://standards.iteh.ai/catalog/standards/sist/7ca26d67-cfe9-4fbc-afe4-c1d4bcab2209/iso-2372-1974>



UDC 621.8.034

Ref. No. ISO 2372-1974 (E)

Descriptors : machinery, vibration, evaluation.

Price based on 9 pages

FOREWORD

ISO (the International Organization for Standardization) is a worldwide federation of national standards institutes (ISO Member Bodies). The work of developing International Standards is carried out through ISO Technical Committees. Every Member Body interested in a subject for which a Technical Committee has been set up has the right to be represented on that Committee. International organizations, governmental and non-governmental, in liaison with ISO, also take part in the work.

Draft International Standards adopted by the Technical Committees are circulated to the Member Bodies for approval before their acceptance as International Standards by the ISO Council.

International Standard ISO 2372 was drawn up by Technical Committee ISO/TC 108, *Mechanical vibration and shock*, and circulated to the Member Bodies in June 1971.

It has been approved by the Member Bodies of the following countries :

Austria	Ireland	Sweden
Belgium	Japan	Switzerland
Egypt, Arab Rep. of	Netherlands	United Kingdom
France	New Zealand	U.S.A.
Germany	South Africa, Rep. of	U.S.S.R.

No Member Body expressed disapproval of the document.

Mechanical vibration of machines with operating speeds from 10 to 200 rev/s – Basis for specifying evaluation standards

0 INTRODUCTION

The problems of noise and vibration control have been brought to the forefront of mechanical and electromechanical engineering technology with the increasing power and continually increasing speed of present-day rotating machinery. As a consequence, more restrictive demands have been placed on the operating quality of the machines.

This International Standard is concerned only with the severity of the mechanical vibration of individual machines and not with the sound energy radiated from individual vibrating parts. The only vibrations considered are those occurring on the surfaces of the machines, on the bearings, or at the mounting points in the frequency range from 10 to 1 000 Hz. The evaluation takes account of the effect of the following general considerations :

- the characteristics of the machine;
- the stresses due to vibration in the machine (for example bearings, coupled machine parts, baseplates, floor);
- the necessity of maintaining the trouble-free operation of a machine which might be jeopardized by malfunction or degradation of components, for instance, excessive rotor deflections which occur when it passes through a resonance or the loosening of frictional joints as a result of shaking forces, and so on;
- the characteristics of the measuring instruments;
- the physical and mental strain on man;
- the effects of the machine vibration on its environment such as adjacently mounted instruments, machines, etc.

It is clear that vibrations measurable at a surface may provide only an indication of the state of the vibratory stresses or motions within a machine. They do not necessarily give evidence of the actual vibratory stresses or motions of critical parts; neither do they ensure that excessive local vibratory stresses may not occur in the machine itself (for example due to internal resonance). In

particular, the torsional vibration of rotating parts may not always be accurately indicated by vibrations measurable on a surface.

Although in some cases the above-mentioned factors may be treated theoretically, evaluation specifications arising therefrom are usually unnecessarily complicated and unsuitable for practical application. It is advantageous and may be decisive for the usefulness of a test that a single value be used to define the vibratory state of the machine under test. For industrial applications, therefore, it is preferable to choose a unit of measure that can be used as a figure of merit and can be displayed on a simple scale. The measured units and the chosen scale should ensure a credible evaluation appropriate to the majority of cases that occur in practice, i.e. the indicated evaluation should not contradict experience already obtained.

In this International Standard, the term "vibration severity"¹⁾, defined as a comprehensive and simple characteristic unit for describing the vibratory state of a machine, is used as the basis of classification and, on the basis of theoretical considerations and practical experience, the root-mean-square value of vibration velocity²⁾ has been chosen as the unit of measurement for indicating vibration severity.

In critical cases and under special conditions, evaluation of the behaviour of a machine based on vibration severity should not be used in lieu of more precisely measured significant parameters, for example, stresses measured at bearings and joints. In general, the use of vibration severity as a criterion provides a relatively reliable evaluation requiring only simple prescribed measurements.

1 SCOPE AND FIELD OF APPLICATION

This International Standard defines the basis for specifying the rules to be employed in evaluating the mechanical vibration of machines in the operating range 10 to 200 rev/s in such a way that comparison is possible with similar measurements obtained from other like machines.

1) "Vibration severity" is a generic term which designates a value such as a maximum, average, or other significant arithmetical value descriptive of a vibration. The vibration severity of a machine is defined as the maximum root-mean-square value of the vibration velocity measured at significant points of a machine, such as a bearing, a mounting point, etc.

2) Unless otherwise stated, the measured vibration values are taken normal to the machine surface.

The purpose of the rules is to evaluate the vibration of "normal" machines with respect to reliability, safety and human perception. It is not intended to apply to the evaluation of vibration of machines with respect to noise control, or in general, to unusual or special purpose machines which are not normally produced in significant quantities, or to machines requiring the study or analysis of vibration characteristics. These latter cases will generally require specific diagnostic treatment, and include a broader frequency range and more specialized instrumentation than considered necessary for the purpose of these general recommendations.

The validity of the rules is restricted to vibrations measured at machine surfaces, such as bearing caps, and within the frequency range 10 to 1 000 Hz and the speed range 10 to 200 rev/s. Where the aim is to evaluate specific machines, range classification levels may be specified in accordance with the rules established in this International Standard.

This International Standard includes an explanation of terms, guidance on measuring conditions and a table of preferred vibration severity ranges. Examples of a recommended method of classification are given in annex A and the rules for converting rms-velocity values to peak-displacement amplitudes are given in annex B.

2 REFERENCE

ISO 2954, *Mechanical vibration of rotating and reciprocating machinery – Requirements for instruments for measuring vibration severity.*¹⁾

3 EXPLANATION OF TERMS

As stated in the Introduction, vibration velocity has been selected as the significant parameter for characterizing the severity of machine vibration. For harmonic vibrations with an instantaneous velocity of $v_i = \hat{v}_i \cos \omega_i t$ (where \hat{v}_i refers to peak value) and vibrations which consist of a number of superposed harmonic vibrations of different frequencies, by definition, the root-mean-square value of the oscillating velocity is used to measure vibration severity. It may be measured and displayed directly by electrical instruments with quadratic characteristic.

From measured vibration velocity versus time records, the rms value of the oscillating velocity may be calculated as follows :

$$v_{rms} = \sqrt{\frac{1}{T} \int_0^T v^2(t) dt} \quad \dots (1)$$

Acceleration, velocity and/or displacement magnitudes (a_j , v_j , s_j respectively; $j = 1, 2, \dots, n$) are determined as functions of the angular velocity ($\omega_1, \omega_2, \dots, \omega_n$) from analyses of recorded spectra. The displacement amplitudes of the vibrations s_1, s_2, \dots, s_n or the oscillating velocity amplitudes v_1, v_2, \dots, v_n or the acceleration

amplitudes a_1, a_2, \dots, a_n are known. The associated rms-velocities characterizing the motion are given by

$$v_{rms} = \sqrt{\left(\frac{1}{2}\right) \left[\left(\frac{\hat{a}_1}{\omega_1}\right)^2 + \left(\frac{\hat{a}_2}{\omega_2}\right)^2 + \dots + \left(\frac{\hat{a}_n}{\omega_n}\right)^2 \right]}$$

$$= \sqrt{\left(\frac{1}{2}\right) (\hat{s}_1^2 \omega_1^2 + \hat{s}_2^2 \omega_2^2 + \dots + \hat{s}_n^2 \omega_n^2)}$$

... (2)

$$= \sqrt{\left(\frac{1}{2}\right) (\hat{v}_1^2 + \hat{v}_2^2 + \dots + \hat{v}_n^2)}$$

In the case where the vibration consists of only two significant frequency components giving beats of rms value v_{min} and v_{max} , v_{rms} may be determined approximately from the relationship

$$v_{rms} = \sqrt{\frac{1}{2} (v_{max}^2 + v_{min}^2)} \quad \dots (3)$$

(standards.iteh.ai)

There is at least one and, perhaps, several key locations on a machine where, in a functional sense, it is important to know whether significant vibration is present. Locations of potential importance include the machine footings (that is, a point of attachment to a foundation) or the bearings. The horizontal and/or vertical components of vibration at these locations may give a direct measure of an undesirable dynamic condition in the machine, for example a large unbalance. The vibration severity of the machine is the maximum rms vibration level measured or calculated, using the appropriate equation (1) to (3), at the selected locations and under a specified set of operational and environmental conditions.

4 GENERAL GUIDE FOR TAKING THE MEASUREMENTS FROM WHICH VIBRATION SEVERITY IS OBTAINED

In this general guide, only the most important conditions are considered. In specific cases, it may be advisable to include other special conditions.

4.1 Measuring equipment²⁾

The vibration of the machines to be tested shall be indicated and recorded by means of mechanical and electrical instruments which comply, where possible, with existing international standards. Applicable standards which give rules or guidelines for making the vibration measurements and reducing the recorded data shall be taken into account.

1) At present at the stage of draft.
2) See ISO 2954.

Before making the vibration measurements, care shall be taken to ensure that the measuring instruments operate accurately over the frequency and velocity range in question, and under the prevailing environmental conditions such as temperature, magnetic fields, surface finish, etc. The response and accuracy of the instruments over the entire range of measurements shall be known.

It is advisable to use instrument types whose properties have been verified by a recognized calibration authority. The measurements system shall be calibrated before use. Care shall also be taken to ensure that the vibration pick-up is properly mounted and that its presence does not significantly affect the vibration characteristics of the machine.

4.2 Support for machine under test

The machine support may significantly affect the vibration levels measured on the machine. The support to be used in the evaluation of particular machines shall be specified in the relevant document, along with their range classification levels. Three possible support conditions are given in 4.2.1 to 4.2.3.

4.2.1 Soft-mounting of machine

Comparable vibration levels of machines under test are most readily achieved when the machines are soft-mounted. A machine shall be supported by a resilient system so that the lowest natural frequency of the machine on its test mounting is less than one-fourth of the frequency of the lowest excitation frequency. In machines with rotating mass components, the natural frequency shall be less than one-fourth of the lowest excitation frequency of the unit. In addition, the effective mass of the resilient system shall not exceed one-tenth of the mass of the machine to be tested (see figure 1).

4.2.2 Mounting of machine on soft-mounted baseplate

The vibration levels of a machine designed to be attached to a rigid baseplate may only be achieved when the machine is tested on such a baseplate. Two categories of baseplates may be used.

- 1) Baseplates which are lighter than the machine and which are intended only to stiffen the machine. In this case, the mass of the test baseplate shall be less than one-fourth that of the machine.
- 2) Baseplates which are heavier than the machine, such as a rigid floor, and which are intended to fix the feet of the machine in space. In this case, the mass of the test baseplate shall be at least twice that of the machine.

In either case, no major structural resonances of the test bed shall occur in the operating range of the machine under test. The baseplate with the machine rigidly attached shall be soft-mounted so that all the rigid-body natural frequencies of the baseplate-machine combination are less than one-fourth of the lowest important excitation frequency of the machine.

4.2.3 Mounting of machine on structural foundation

When the machine to be tested is of such a type and size that it cannot readily be soft-mounted, it is generally mounted on a given structural foundation. It must be noted, however, that in such cases, a valid comparison of the vibration severity levels for machines of the same type can only be made if the foundations concerned, including soils, have similar dynamic characteristics.

If this condition is not met, the vibration severity level shall be defined for each particular case.

NOTE — Very large machines can only be tested *in situ*; the general principles of these recommendations still apply to such machines but must be supplemented by requirements to suit each case.

4.3 Points of measurement

Points of measurement should preferably be chosen where the vibration energy is transmitted to the resilient mountings or to other parts of the system. For machines which include rotating masses, the bearings and mounting points of the machine are preferred points of measurement. In individual cases it may be advisable to choose other points of measurement, for example at the marked points in figure 2. Measurements may be made in the directions of the three mutually perpendicular axes.

4.4 Operational conditions during testing

Operating conditions such as temperature, load, speed, etc., shall be specified prior to the test and actual conditions recorded. For variable-speed machines, the measurements shall be made at many speeds in order to locate the resonance frequencies which occur and evaluate their effects on the measured vibration characteristics.

5 SCALE FOR THE EVALUATION OF VIBRATION INTENSITY

5.1 Based on experience, vibrations with the same rms velocity anywhere in the frequency band 10 to 1 000 Hz are generally considered to be of equal severity. Succeeding ranges of the evaluation classification should have a ratio of 1 : 1,6, giving a step of 4 dB between severity levels. A difference of 4 dB yields a velocity increase (or decrease) which represents a significant change in the vibratory response in most machines.

This permits the construction of a general scale similar to that of table 1 which is independent of and not restricted to a particular group of machines. From this it will be seen that the term "vibration severity" may be used in such a way that it does not depend on individual judgement factors; it is, in effect, an independent parameter which may be used to construct any required evaluation classification.

Possible differences concerning the evaluation by users and manufacturers can usually be avoided if prior agreement is reached on the required accuracy of measurement.

5.2 Criteria for the evaluation of specific types of machines

The vibration severity value associated with a particular range classification depends on the size and mass of the vibrating body, the characteristics of the mounting system,

the output and the use of the machine. It is therefore necessary to take account of the various purposes and circumstances concerned when specifying different ranges from table 1 for different types of machines. For example, the severity range corresponding to "dangerous" or "acceptable" might be expected to differ according to whether gyroscopes or boiler fans were concerned.

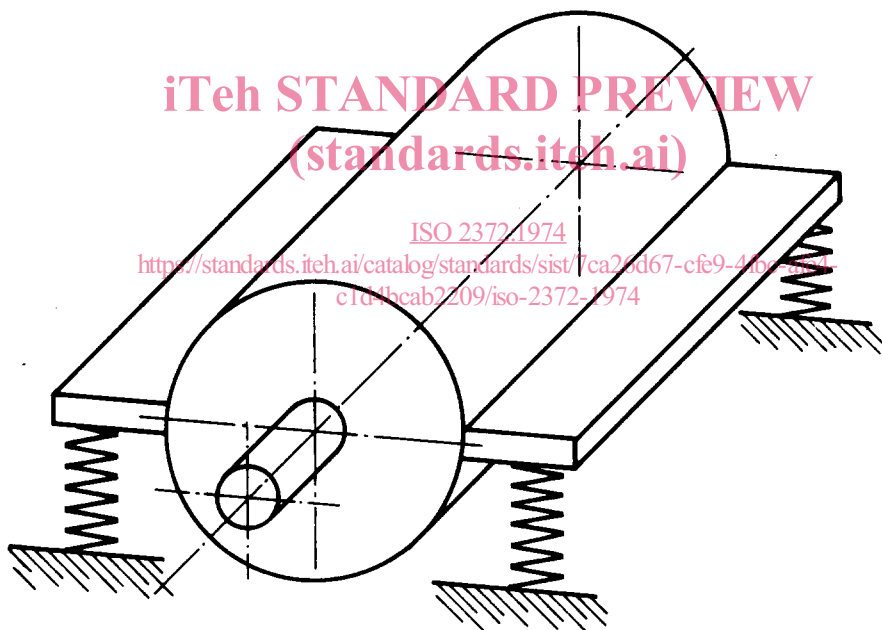
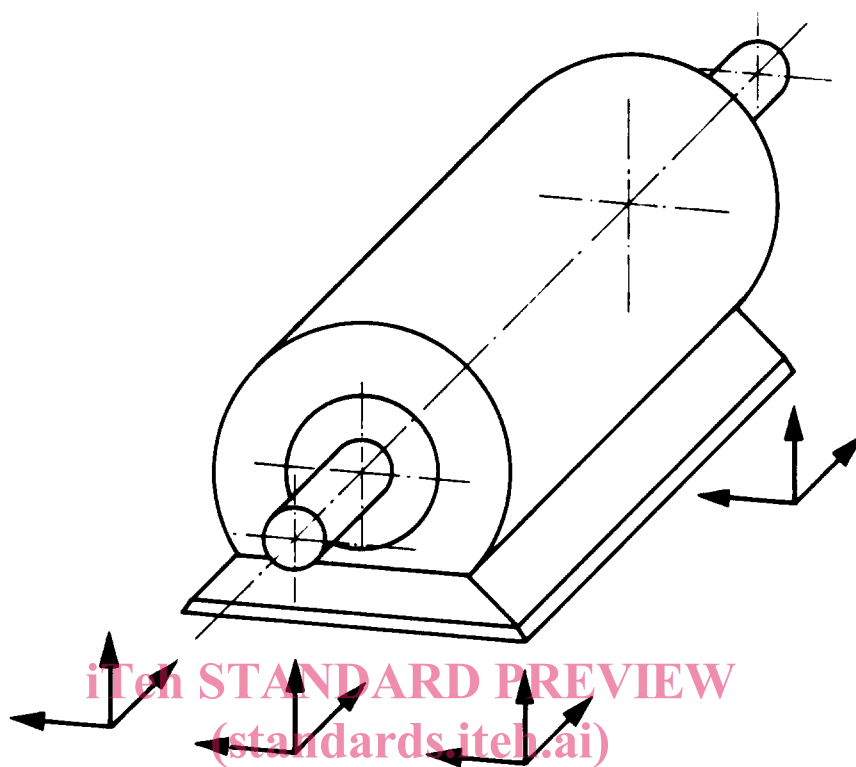

FIGURE 1 – Schematic arrangement of a machine soft suspension test mount



ISO 2372:1974
 FIGURE 2 – Possible measuring points on a small machine (Measuring directions on bearings, supports and flanges)

TABLE 1 – Vibration severity ranges (10 to 1 000 Hz)

Range classification	Velocity range (rms) (effective value of the vibratory velocity)			
	mm/s		in/s	
	over	up to	over	up to
0,11	0,071	0,112	0.002 8	0.004 4
0,18	0,112	0,18	0.004 4	0.007 1
0,28	0,18	0,28	0.007 1	0.011 0
0,45	0,28	0,45	0.011 0	0.017 7
0,71	0,45	0,71	0.017 7	0.028 0
1,12	0,71	1,12	0.028 0	0.044 1
1,8	1,12	1,8	0.044 1	0.070 9
2,8	1,8	2,8	0.070 9	0.110 2
4,5	2,8	4,5	0.110 2	0.177 2
7,1	4,5	7,1	0.177 2	0.279 5
11,2	7,1	11,2	0.279 5	0.440 9
18	11,2	18	0.440 9	0.708 7
28	18	28	0.708 7	1.102 4
45	28	45	1.102 4	1.771 6
71	45	71	1.771 6	2.795 3

ANNEX A

EXAMPLES

(For guidance purposes only)

In order to show how the recommended method of classification may be applied, examples of specific classes of machines are given below. It should be emphasized, however, that they are simply examples and it is recognized that other classifications are possible and may be substituted in accordance with the circumstances concerned. As and when circumstances permit, recommendations for acceptable levels of vibration severity for particular types of machines will be prepared. At present, experience suggests that the following classes are appropriate for most applications.

- Class I :** Individual parts of engines and machines, integrally connected with the complete machine in its normal operating condition. (Production electrical motors of up to 15 kW are typical examples of machines in this category.)
- Class II :** Medium-sized machines, (typically electrical motors with 15 to 75 kW output) without special foundations, rigidly mounted engines or machines (up to 300 kW) on special foundations.
- Class III :** Large prime movers and other large machines with rotating masses mounted on rigid and heavy foundations which are relatively stiff in the direction of vibration measurement.
- Class IV :** Large prime movers and other large machines with rotating masses mounted on foundations which are relatively soft in the direction of vibration measurement (for example turbo-generator sets, especially those with light-weight substructures).
- Class V :** Machines and mechanical drive systems with unbalanceable inertia efforts (due to reciprocating parts), mounted on foundations which are relatively stiff in the direction of vibration measurement.
- Class VI :** Machines and mechanical drive systems with unbalanceable inertia effects (due to reciprocating parts), mounted on foundations which are relatively soft in the direction of vibration measurements; machines with rotating slack-coupled masses such as beater shafts in grinding mills; machines, like centrifugal machines, with varying unbalances capable of operating as self-contained units without connecting components; vibrating screens, dynamic fatigue-testing machines and vibration exciters used in processing plants.

The examples in the first four classes have been selected because there is a substantial body of experience on which to base their evaluation.

A suggested order of quality judgment: A up to and including D, with double-step severity ranges is given in table 2. A motor or a machine may be qualified according to the values in table 2, when the maximum measured values at important operating points (particularly the bearings) occur in the appropriate range of table 2.

Following Rathbone, it has been common practice to discriminate between vibration levels measured in the horizontal and vertical directions on machines of Class III. In most cases, the Rathbone tolerance for horizontal vibration is double that for vertical vibrations. Since machines with relatively soft foundations are treated in a separate category, the less exacting judgement for horizontal vibrations called for in Classes III and IV does not seem to be justified today. For axial vibrations, on the other hand, a less exacting requirement may be permissible.

The machines in Classes V and VI, especially reciprocating engines, vary widely in their construction and the relative influence of inertia forces; therefore, they vary considerably in their vibration characteristics. For this reason it is difficult to classify them in the same manner as the machines in the first four classes. In Class V the relatively high natural frequencies associated with their stiff mounting systems are easily excited by the multiple frequencies generated in the machine.

For these machines, rms vibration velocities of 20 to 30 mm/s and higher may occur without causing trouble. In addition, if couples are acting, large displacements may be caused at points which are at some distance from the centre of gravity.

The resiliently mounted machines in Class VI permit a greater tolerance in this respect. There is an isolation effect and the forces transmitted by the mounting into the surroundings are small. Under these circumstances vibration levels measured on the machine side of the mounting system are greater than those measured when the machine is fastened to a large relatively rigid support. Rms velocities of 50 mm/s or higher may be measured on motors with high rotational speed. Attached parts may have still greater vibration velocities because they are frequently subject to resonance effects. While passing through resonance, rms velocities of the order of 500 mm/s may occur for short intervals.

In this case, factors other than those associated with electrical motors are decisive in making an evaluation of the machine's performance. In general, the vibrational motion should not cause such damage as loosening of parts or the breaking of electrical, hydraulic or pneumatic connections.

TABLE 2 – Vibration severity ranges and examples of their application to small machines (Class I), medium size machines (Class II), large machines (Class III) and turbo machines (Class IV)

Ranges of vibration severity		Examples of quality judgement for separate classes of machines			
Range	rms-velocity v (in mm/s) at the range limits	Class I	Class II	Class III	Class IV
0,28	0,28	A	A	A	A
0,45	0,45				
0,71	0,71				
1,12	1,12	B	B	B	B
1,8	1,8	C	C	C	C
2,8	2,8				
4,5	4,5				
7,1	7,1	D	D	D	D
11,2	11,2				
18	18				
28	28				
45	45				
71	71				

iteh STANDARD PREVIEW
(standards.iteh.ai)

ISO 2372:1974

<https://standards.iteh.ai/catalog/standards/sist/7ca26d67-cfe9-4fbc-afe4-c1d4bcab2209/iso-2372-1974>