



Standard Test Method for Behavior of Materials in a Vertical Tube Furnace at 750°C¹

This standard is issued under the fixed designation E136; the number immediately following the designation indicates the year of original adoption or, in the case of revision, the year of last revision. A number in parentheses indicates the year of last reapproval. A superscript epsilon (ϵ) indicates an editorial change since the last revision or reapproval.

This standard has been approved for use by agencies of the Department of Defense.

1. Scope

1.1 This fire-test-response test method covers the determination under specified laboratory conditions of combustion characteristics of building materials. It is not intended to apply to laminated or coated materials.

1.2 This test method references notes and footnotes that provide explanatory information. These notes and footnotes, excluding those in tables and figures, shall not be considered as requirements of this test method.

1.3 The values stated in SI units are to be regarded as standard. The values given in parentheses are for information only.

1.4 Limitations of the test method are discussed in 1.1 and Annex A1.

1.5 *This standard is used to measure and describe the response of materials, products, or assemblies to heat and flame under controlled conditions, but does not by itself incorporate all factors required for fire-hazard or fire-risk assessment of the materials, products, or assemblies under actual fire conditions.*

1.6 *This standard does not purport to address all of the safety concerns, if any, associated with its use. It is the responsibility of the user of this standard to establish appropriate safety and health practices and determine the applicability of regulatory limitations prior to use.*

1.7 *Fire testing is inherently hazardous. Adequate safeguards for personnel and property shall be employed in conducting these tests.*

2. Referenced Documents

2.1 ASTM Standards:²

D1929 Test Method for Determining Ignition Temperature of Plastics

D3174 Test Method for Ash in the Analysis Sample of Coal and Coke from Coal

E84 Test Method for Surface Burning Characteristics of Building Materials

E176 Terminology of Fire Standards

2.2 ISO Standard:³

ISO 1182 Noncombustibility Test for Building Materials

ISO 13943 Fire Safety-Vocabulary

2.3 Other Standard:

BS 476 Combustibility Test of Materials³

3. Terminology

3.1 Definitions—For definitions of terms found in this test method, refer to Terminology E176 and ISO 13943. In case of conflict, the definitions given in Terminology E176 shall prevail.

4. Summary of Test Method

4.1 This test method uses a furnace consisting of a ceramic tube containing an electric heating coil to expose building materials to a temperature of 750°C (1382°F) until failure occurs or for at least 30 min.

4.2 The furnace consists of two concentric vertical refractory tubes.

4.3 Thermocouples are used to assess the temperature increases resulting from combustion of the building material.

4.4 Visual observation is used to assess the occurrence of flaming.

¹ This test method is under the jurisdiction of ASTM Committee E05 on Fire Standards and is the direct responsibility of Subcommittee E05.23 on Combustibility. Current edition approved Feb. 1, Oct. 15, 2009. Published March/November 2009. Originally approved in 1958. Last previous edition approved in 2004/2009 as E136 – 04 ϵ . DOI: 10.1520/E0136-09A.

² For referenced ASTM standards, visit the ASTM website, www.astm.org, or contact ASTM Customer Service at service@astm.org. For Annual Book of ASTM Standards volume information, refer to the standard's Document Summary page on the ASTM website.

³ Available from American National Standards Institute (ANSI), 25 W. 43rd St., 4th Floor, New York, NY 10036, http://www.ansi.org.

5. Significance and Use

5.1 While actual building fire exposure conditions are not duplicated, this test method will assist in indicating those materials which do not act to aid combustion or add appreciable heat to an ambient fire.

5.2 Materials passing the test are permitted limited flaming and other indications of combustion.

6. Apparatus

6.1 The test apparatus, as shown in Fig. 1, shall consist primarily of the following:

6.1.1 *Refractory Tubes*—Two concentric, refractory tubes, 76 and 102 mm (3 and 4 in.) in inside diameter and 210 to 250 mm (8½ to 10 in.) in length, with axes vertical, and with heat applied by electric heating coils outside of the larger tube. A controlled flow of air is admitted tangentially near the top of the annular space between the tubes and passes to the bottom of the inner tube. The outer tube rests on a refractory bottom and the inner tube rests on three spacer blocks so as to afford a total opening under the inner tube equal to or greater than that of the annular space. The refractory bottom plate has a removable plug for cleaning.

6.1.2 *Transparent Cover*—A transparent cover of heat-resistant glass or other transparent material shall be provided over the top of the inner tubes. The cover shall have a circular opening 28.7 ± 0.8 mm ($1\frac{1}{8} \pm \frac{1}{32}$ in.) centered over the axis of the tubes. This opening has an area of 645 mm^2 (1.0 in.²). The cover shall be in two equally-sized, movable parts.

6.1.3 *Thermocouples* and an automatically recording device shall be provided. The thermocouples shall be located as follows:

6.1.3.1 Thermocouple T_1 is located in the center of the air space between the two concentric, refractory tubes; approximately 204 mm (8 in.) down from the top of the 102-mm (4-in.) diameter tube (Note 1).

6.1.3.2 Thermocouple T_3 is located at the approximate geometric center of the specimen.

6.1.3.3 Thermocouple T_4 is located on the surface, in contact with the test specimen; in the same horizontal plane as T_3 .

6.1.3.4 Thermocouples T_1 , T_3 and T_4 shall have a time constant (time to reach 63.2 % of the furnace air temperature of 750°C (1382°F)) of 5 to 10 s (Note 2).

NOTE 1—Thermocouple T_1 is used for better regulation of the temperature of the air in the furnace space.

NOTE 2—Ungrounded, metallic-sheathed thermocouples of 1-mm diameter have been found to meet the time constant requirements.

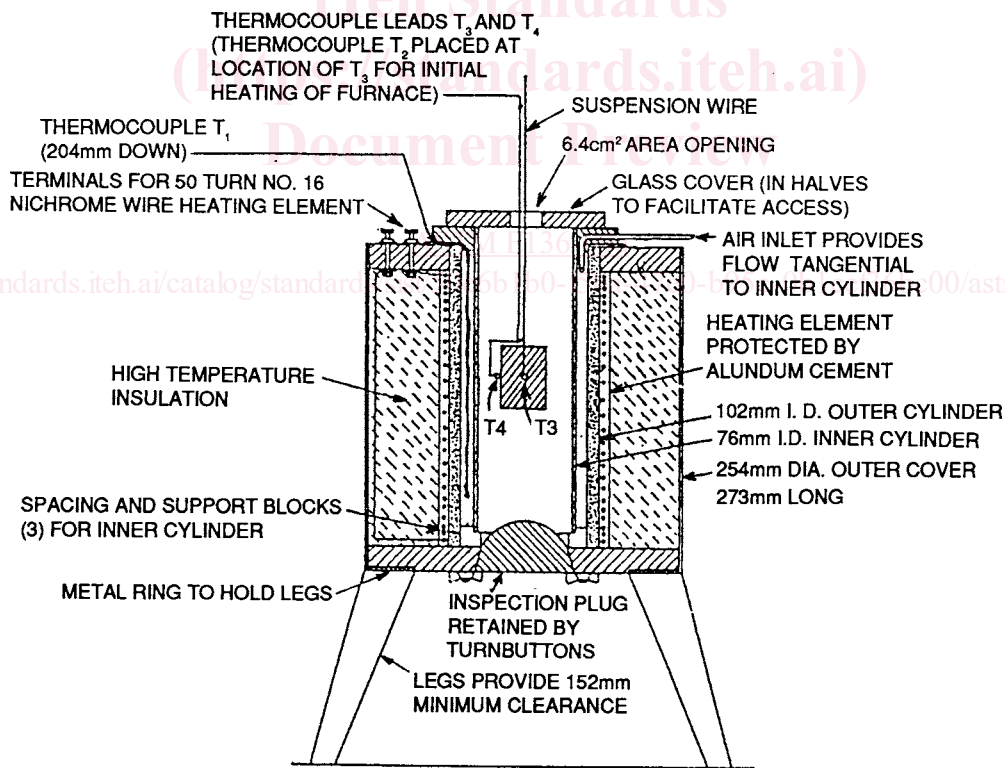

NOTE—Inch-Pound Equivalents

in.	3	4	6	10	10¾	1 in. ²	No. 16 Awg
mm	76	102	152	254	273	6.4 cm ²	1.29

FIG. 1 Cross Section of Furnace Assembly

6.2 *Specimen Holder*—The specimen holder for solid test specimens shall be as shown in Fig. 2.

6.2.1 Test specimens in granular or powder form shall be contained in thin-wall, open-top vessels of inert materials whose outside dimensions conform to the test specimen shape and maximum size specified in 7.1. These vessels shall have walls of either solid or mesh construction.

6.3 *Test Specimen Location*—During the test, the geometric center of the test specimen shall be located at the geometric center ± 3 mm ($\pm 1/8$ in.) of the 76-mm (3-in.) diameter tube.

7. Test Specimens

- 7.1 All test specimens shall be 38 by 38 by 51 ± 2.5 mm (1.5 by 1.5 by 2.0 ± 0.1 in.).
- 7.2 The test specimens shall be dried at $60 \pm 3^\circ\text{C}$ ($140 \pm 5^\circ\text{F}$) for not less than 24 h but no more than 48 h.
- 7.3 Test specimens shall then be placed in a desiccator to cool at least 1 h before testing.
- 7.4 Not less than four identical specimens shall be tested.

8. Procedure

8.1 *Test Room Setup*:

8.1.1 Conduct the test at room conditions of $21 \pm 3^\circ\text{C}$ ($70 \pm 5^\circ\text{F}$).

8.1.2 The test apparatus shall not be exposed to drafts or any other form of direct sunlight or artificial illumination which would adversely affect the observation of flaming inside the furnace.

8.1.3 The room temperature shall not change by more than 3°C (5°F) during a test.

8.2 *Air Flow*—Provide an external air source to supply clean air through a metal tube located near the top of the test apparatus, tangentially between the annular spaced ceramic tubes. The air shall be supplied at a steady and controllable rate of $0.0027 \text{ m}^3/\text{min}$ ($0.10 \text{ ft}^3/\text{min}$) $\pm 20\%$, which will give an air flow of 3 m (10 ft)/min past a loaded test specimen in the furnace at 750°C (1382°F). Measure the air at room temperature, as specified in 8.1.1 and meter by a rotameter or other metering device in line with the metal tube.

8.3 *Stabilized Furnace Temperature*—Prior to the initial heating period insert a thermocouple, T_2 , into the furnace from the top and place it where the geometric center of the test specimen will be during the test. Use this thermocouple to establish the stabilized furnace temperature.

8.4 *Test Furnace Setup*—Prepare the furnace by bringing the temperature of thermocouple T_2 , located in the furnace at the position to be occupied by the geometric center of the specimen, to a temperature of $750 \pm 5.5^\circ\text{C}$ ($1382 \pm 10^\circ\text{F}$). Maintain the temperature in the unloaded furnace for at least 15 min to ensure stability.

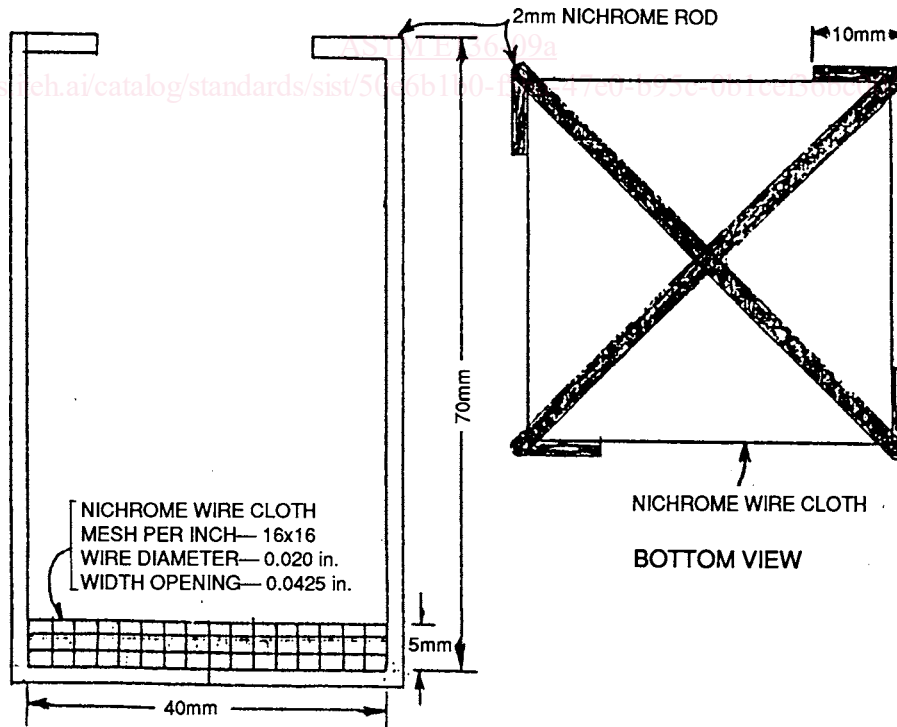

SIDE VIEW

FIG. 2 Specimen Holder for Solid Specimens

8.5 Once the operating temperature has been established by thermocouple, T_2 , note the temperature on thermocouple T_1 and control the test chamber during the test to the observed T_1 temperature reading. It is acceptable to use T_3 as T_2 .

8.6 *Test Procedure*—As rapidly as possible, insert the test specimen into the furnace with thermocouple T_3 inserted from the top of the test specimen to its geometric center and thermocouple T_4 attached to the side surface of the test specimen.

8.6.1 Close the top cover to the 6.4-cm²(1-in. ²) opening immediately after insertion of the test specimen. Readings for thermocouples T_3 and T_4 shall be made at intervals (Note 3) not to exceed 10 s during the first 5 min, and as often as necessary afterwards to produce a smooth curve. Do not change the regulation of the current through the heating coils and the air flow during the test.

NOTE 3—A continuous read-out recording is preferred since it is possible for the maximum temperature to occur between the 10-s intervals.

8.6.2 Continue the test until the temperatures at thermocouples T_3 and T_4 have reached maxima, or until it is evident that the specimen does not pass this test.

8.6.3 After 30 min of testing have elapsed, or at any time subsequent to that, testing shall be discontinued if, over the previous 10 minutes, the temperature measured at the center thermocouple T_3 has risen by no more than 1°C in any one minute. The final temperature reading shall be recorded as the maximum temperature.

8.7 Throughout the test make and record visual observations on the test specimens, noting quality, quantity, or intensity and duration of flaming or smoking, or both, and change of state.

8.8 Note and record the time of occurrence of any flaming and the duration of such flaming in seconds.

NOTE 4—Flaming is sometimes difficult to identify. Some specimens exhibit only flame as a steady blue-colored luminous gas zone. Do not ignore this and note it under “observations during test” in the test report.

8.9 Weigh each test specimen before and after testing and record the weight, in g, before and after the test for each test specimen.

8.10 Record the temperatures (initial, maximum and final), in °C, as measured by the appropriate thermocouples.

9. Calculation

9.1 Calculate and record the weight loss for each of the test specimens, expressed as a percentage of the initial weight of the test specimen, to the nearest 1 %.

9.2 Calculate and record the temperature rise, in °C, for each of the test specimens.

9.2.1 Calculate the temperature rise as the difference between the maximum temperature and the initial temperature, as measured by thermocouple, T_3 .

10. Report

10.1 Report the material as passing the test if at least three of the four test specimens tested meet the individual test specimen criteria detailed in 10.2 or 10.3. The three test specimens do not need to meet the same individual test specimen criteria.

10.2 If the weight loss of the test specimen is 50 % or less, the material passes the test when the criteria in 10.2.1 and in 10.2.2 are met:

10.2.1 The recorded temperatures of the surface and interior thermocouples do not at anytime during the test rise more than 30°C (54°F) above the stabilized furnace temperature measured at T_2 prior to the test.

10.2.2 There is no flaming from the test specimen after the first 30 s.

10.3 If the weight loss of the specimen exceeds 50 %, the material passes the test when the criteria in 10.3.1 and in 10.3.2 are met:

10.3.1 The recorded temperature of the surface and interior thermocouples do not, at any time during the test, rise above the stabilized furnace temperature measured at T_2 prior to the test.

10.3.2 No flaming from the test specimen is observed at any time during the test.

11. Precision and Bias

11.1 No information is presented about the precision and bias of this test method for measuring combustion characteristics since the test results are nonquantitative and are reported as pass or fail. (See X1.6.)

11.2 There have been attempts to determine precision and bias for some of the numerical results for this test method but the results have not been made public.

12. Keywords

12.1 building materials; combustion; heated tube; limited combustion; Setchkin furnace; tube furnace; vertical tube furnace

A1. TEST LIMITATIONS

A1.1 At present, there are a number of limitations in the test method and its application that must be recognized. Materials are not necessarily tested in the nature and form used in building applications. The test specimen consists of a small, specified volume that is either (1) cut from a thick sheet; (2) assembled from multiple thicknesses of thin sheets; or (3) placed in a container if composed of granular powder or loose fiber materials.

A1.2 The test method does not provide a measure of an intrinsic property. Test results apply to the specific test apparatus and test conditions and will potentially vary when changes are made to one or more of the following: (1) the size, shape, and arrangement of the specimen; (2) the distribution of organic content; (3) the exposure temperature; (4) the air supply; (5) the location of thermocouples.

A1.3 The test method does not provide a quantitative measure of heat generation or combustibility; it simply serves as a test method with selected (end point) measure of limited combustibility.

A1.4 The test method is not suitable or satisfactory for materials that soften, flow, melt, or otherwise separate from the measuring thermocouple.

A1.5 The test method does not measure the self-heating tendencies of large masses of materials. For example, it provides no indication of potential self-heating of resin-impregnated mineral fiber insulation or oil-coated metal products.

APPENDIX

(Nonmandatory Information)

X1. COMMENTARY

X1.1 Introduction

X1.1.1 The difference in fire risk between a combustible building material and a noncombustible (or incombustible) one is generally obvious. However, some materials may contain only a limited amount of combustible content and may not contribute appreciably to an ambient fire. The term noncombustible, while in recognized use as indicating a material that will not ignite or burn, is indefinite in its application unless referenced to a well defined testing procedure.

X1.2 Definition

X1.2.1 Most dictionaries have defined noncombustible in simple terms, such as that used in the 1920 edition of the National Building Code promulgated by the National Board of Fire Underwriters (NBFU): Incombustible materials or construction are those that “will not ignite or burn when subjected to fire.” In 1943 the same code redefined incombustible construction as “assemblies which do not involve materials of such kind or quantity or so contained as to burn during exposure in a test fire or continue flaming or ignite after the furnace is shut off.”

X1.2.2 About this same time Committee C05 (now E05) and the New York City Building Code suggested adding a reference of 649°C (1200°F) as the fire exposure temperature. By 1949 the term incombustible was changed to noncombustible in the National Building Code without definition. The first edition of the BOCA Basic Building Code (1950) defined a noncombustible material as “any material which will neither ignite or actively support combustion in air at a temperature of 649°C [1200°F] during an exposure of five minutes in a vented tube or vented crucible furnace.”

X1.2.3 The 1955 edition of the NBFU National Building Code established a definition for noncombustible material (1)⁴ that was subsequently adopted by other model codes, the Life Safety Code (2), and most local codes. The adopted definition was as follows:

Noncombustible as applied to a building construction material means a material that, in the form in which it is used, falls in one of the following groups (a) through (c). It does not apply to surface finish materials nor to the determination of whether a material is noncombustible from the standpoint of clearances to heating appliances, flues or other sources of high temperature. No material shall be classed as noncombustible which is subject to increase in combustibility or flame spread rating beyond the limits herein established, through the effects of age, moisture or other atmospheric condition. Flame spread rating as used herein refers to ratings obtained in accordance with Test Method E84.

a) Materials no part of which will ignite and burn when subjected to fire. Any material that liberates flammable gas when heated to a temperature of 750°C (1382°F), for 5 min shall not be considered noncombustible within the meaning of this paragraph.

b) Materials having a structural base of noncombustible material, as defined in (a), with a surfacing not over 1/8-in. thick that has a flame spread rating not higher than 50.

⁴ The boldface numbers in parentheses refer to the list of references appended to this method.

c) Materials, other than as described in (a) or (b), having a surface flame spread rating not higher than 25 without evidence of continued progressive combustion and of such composition that surfaces that would be exposed by cutting through the material in any way would not have a flame spread rating higher than 25 without evidence of continued progressive combustion.

X1.2.4 In adopting this definition, NBFU stated that it was based on a determination of which materials “could be properly classed as noncombustible and then fixing the qualifying conditions in the definition to include these materials.” The definition was considered to apply to materials used for the walls, roofs, or other structural parts of buildings, but not to surface finish materials and not to the determination of whether a material is noncombustible from the standpoint of clearances to heating appliances, flues, or other sources of high temperature.

X1.2.5 After Test Method E136 was promulgated, (initially as a tentative in 1958, then as a full standard in 1965), many building codes replaced either part (a) of the NBFU definition or the entire definition with the specification that materials shall have been successfully tested in accordance with Test Method E136. In 1973, the American Insurance Association (successor to NBFU) introduced a definition of a limited-combustible material and redefined a noncombustible material as one that, in the form in which it is used and under the conditions anticipated, will not ignite, burn, support combustion, or release flammable vapors, when subjected to fire or heat.

X1.2.6 To avoid misinterpretation in the use of the term noncombustible, Committee E05 has decided to limit the use of this term, and it was eliminated from the title and text of Test Method E136 in 1979. The current title provides a more specific description of the restricted nature of the test method.

X1.3 Origin and Early History of Test Method E136

X1.3.1 In 1912 R. E. Prince developed a furnace apparatus to study the ignitability of various wood species and investigate the effect of fire-retardant chemical treatments on their ignition characteristics (3,4). This apparatus as shown in Fig. X1.1 consisted essentially of a quartz cylinder 76 mm [3 in.] in diameter and 254 mm [10 in.] long, which was wound with a high electrical resistance nichrome ribbon. The cylinder was heavily insulated with asbestos. A lower chamber of about 89 mm (3.5 in.) in diameter and 203 mm (8 in.) deep formed a continuation of the upper chamber. A natural draft was used. No attempt was made to control the temperature or humidity of the air passing through the apparatus. The test temperature was 200°C (392°F). The 32 by 32 by 102-mm (1¼ by 1¼ by 4-in.) specimen was first weighted and then lowered in the hot quartz cylinder where it remained until it ignited or for 40 min. Ignition time, if it occurred, was recorded and the specimen was then moved into the lower cooler chamber and allowed to burn for not more than 3 min. Loss of weight was then determined. Intensity of burning was also recorded.

X1.3.2 An apparatus quite similar to the Prince-FPL apparatus was later adopted as part of the British Standard 476-1932. In a revision of BS 476 in 1953, the test was renamed, and the furnace was preheated and maintained at 750°C (1382°F) prior to

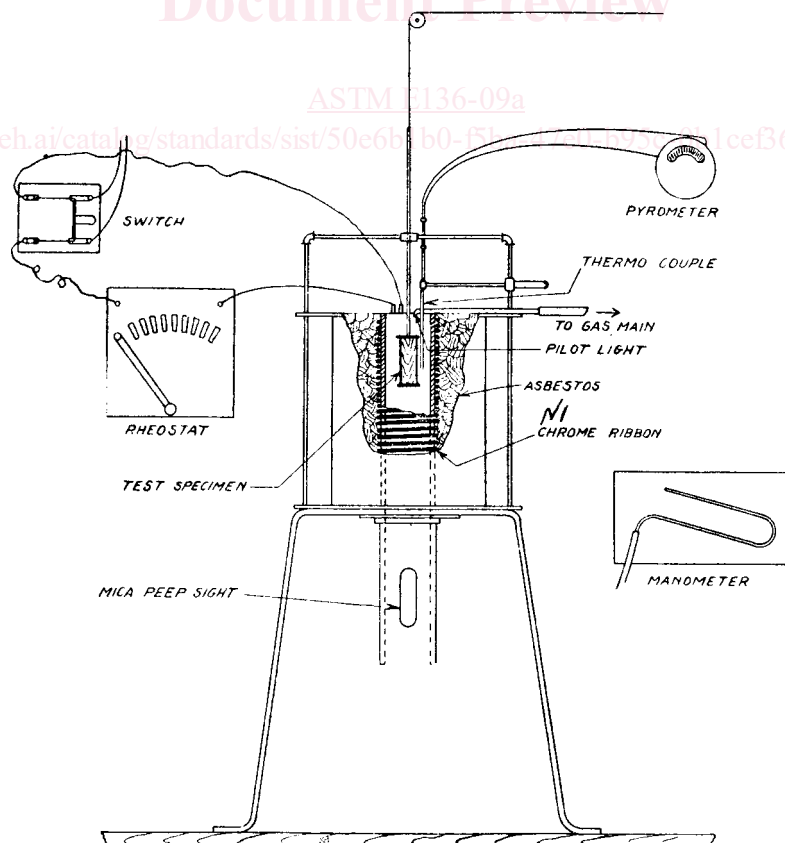

FIG. X1.1 Inflammability Apparatus No. 1