



Designation: D3711 – 95(Reapproved 2009)

## Standard Test Method for Deposition Tendencies of Liquids in Thin Films and Vapors<sup>1</sup>

This standard is issued under the fixed designation D3711; the number immediately following the designation indicates the year of original adoption or, in the case of revision, the year of last revision. A number in parentheses indicates the year of last reapproval. A superscript epsilon ( $\epsilon$ ) indicates an editorial change since the last revision or reapproval.

### 1. Scope

1.1 This test method covers the determination of the tendency of liquids in thin films and of vapors to form deposits on metal surfaces. The test method applies to both petroleum-based and synthetic lubricants, hydraulic fluids, heat-transfer fluids, and related materials.<sup>2</sup>

1.2 The values stated in SI units are to be regarded as the standard. In cases where materials, products, or equipment are available in inch-pound units only, SI units are omitted.

1.3 *This standard does not purport to address all of the safety concerns, if any, associated with its use. It is the responsibility of the user of this standard to establish appropriate safety and health practices and determine the applicability of regulatory limitations prior to use.* For specific warning statements, see Section 7 and Annex A2.

### 2. Referenced Documents

2.1 *ASTM Standards:*<sup>3</sup>

[D216 Method of Test for Distillation of Natural Gasoline](#)  
(Withdrawn 1988)<sup>4</sup>

[D323 Test Method for Vapor Pressure of Petroleum Products \(Reid Method\)](#)

[D4057 Practice for Manual Sampling of Petroleum and Petroleum Products](#)

[D4177 Practice for Automatic Sampling of Petroleum and Petroleum Products](#)

<sup>1</sup> This test method is under the jurisdiction of ASTM Committee D02 on Petroleum Products, Liquid Fuels, and Lubricants and is the direct responsibility of Subcommittee D02.L0.07 on Engineering Sciences of High Performance Fluids and Solids (Formally D02.1100).

Current edition approved Oct. 1, 2009. Published November 2009. Originally approved in 1978. Last previous edition approved in 2005 as D3711–95(2005). DOI: 10.1520/D3711-95R09.

<sup>2</sup> United States Patent 2,669,865. Joseph Cole and John Krawetz.

<sup>3</sup> For referenced ASTM standards, visit the ASTM website, [www.astm.org](http://www.astm.org), or contact ASTM Customer Service at [service@astm.org](mailto:service@astm.org). For *Annual Book of ASTM Standards* volume information, refer to the standard's Document Summary page on the ASTM website.

<sup>4</sup> The last approved version of this historical standard is referenced on [www.astm.org](http://www.astm.org).

[E230 Specification and Temperature-Electromotive Force \(EMF\) Tables for Standardized Thermocouples](#)

2.2 *ANSI Standard:*

[C96.1 Temperature Measurement Thermocouples.](#)<sup>5</sup>

### 3. Terminology

3.1 *Definitions of Terms Specific to This Standard:*

3.1.1 *deposit tendency, n*—deposition tendency of a thin film or vapor is an index of the propensity of a material to form carbonaceous residues on hot surfaces in contact with the liquid or vapor phase of the sample.

### 4. Summary of Test Method

4.1 The test specimen is allowed to flow slowly in a thin film over a steel test specimen in a constant-temperature chamber (furnace liner). Circulation of the sample from the sump to the heated surface and back to the sump is accomplished by means of a peristaltic pump. After the prescribed test period, the steel test specimen is removed from the apparatus and evaluated. The masses of deposits remaining after washing with pentane, after washing with chloroform, and after wiping with a paper tissue are reported.

4.2 An optional procedure (see Annex A1) provides a method for the determination of the tendency of sample vapors to form deposits on heated surfaces. A second test specimen is placed in the vapor space over a thin flowing film of the liquid in a constant-temperature chamber (furnace liner). After circulation of the test liquid for a specified time the deposits on the test specimen exposed to the liquid and the vapor phases are measured in the manner described in 4.1.

### 5. Significance and Use

5.1 The test method shall measure the deposit formation tendencies of liquids on steel surfaces in air at 101.3 KPa (1-atm) pressure. Other surfaces and other atmospheric media

<sup>5</sup> Available from American National Standards Institute (ANSI), 25 W. 43rd St., 4th Floor, New York, NY 10036, <http://www.ansi.org>.

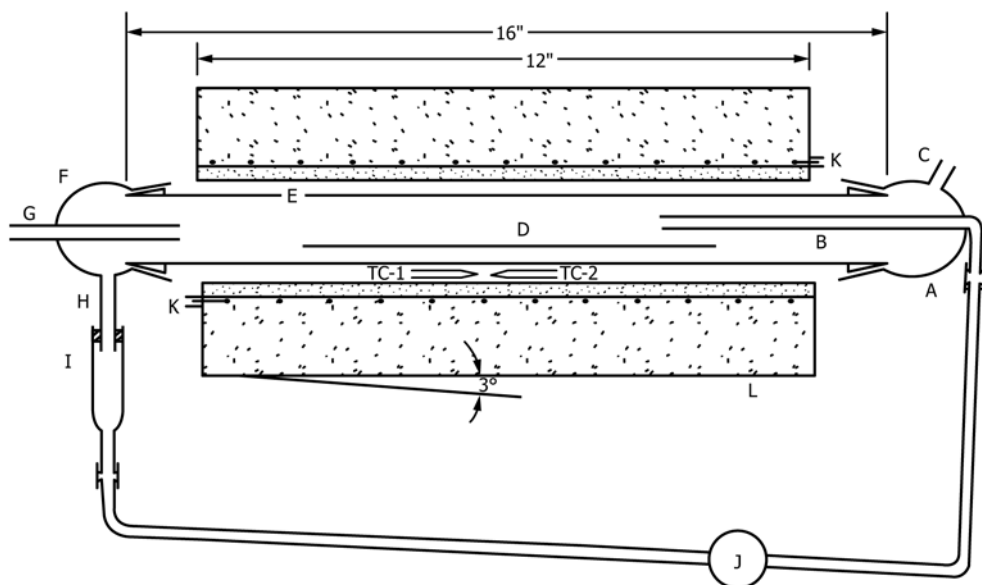

in.	mm
12	304.8
16	406.4

- A—Inlet end cap
- B—Sample delivery tube
- C—Gas atmosphere outlet
- D—Metal test piece for thin liquid films
- E—Furnace liner (with standard taper male end joints)
- F—Outlet end cap
- G—Gas atmosphere inlet
- H—Sample outlet tube
- I—Sample sump
- J—Peristaltic pump
- K—Insulated terminals of furnace heater element
- L—Tube furnace
- TC1—Control thermocouple for furnace controller
- TC2—Thermocouple for test temperature read out

FIG. 1 Tube Furnace

may be substituted for steel and air at 1 atm provided that the substitution is noted in the test report.

## 6. Apparatus

6.1 *Tube Furnace*, with heating chamber 305 mm (12 in.) long by 35 mm (1 3/8 in.) in diameter<sup>6,7</sup> (see Fig. 1).

6.2 *Furnace Liner* (constant-temperature chamber)—See Fig. 2.

6.3 *Temperature Controller*.<sup>7,8</sup>

6.4 *Potentiometer*, direct-temperature readout.<sup>7,9</sup>

6.5 *Thermocouples*, for temperature control and read-out in accordance with ANSI C96.1 (see Specification E230).

<sup>6</sup> The sole source of supply of the apparatus known to the committee at this time is the Type FD303A combustion furnace, Hoskins Manufacturing Co., Detroit, MI 48232.

<sup>7</sup> If you are aware of alternative suppliers, please provide this information to ASTM International Headquarters. Your comments will receive careful consideration at a meeting of the responsible technical committee,<sup>1</sup> which you may attend.

<sup>8</sup> The sole source of supply of the apparatus known to the committee at this time is a Model 520 Solid State Controller, Barber Colman Co., Rockford, IL.

<sup>9</sup> The sole source of supply of the apparatus known to the committee at this time is a Model 400A digital temperature indicator, Doric Scientific, San Diego, CA.

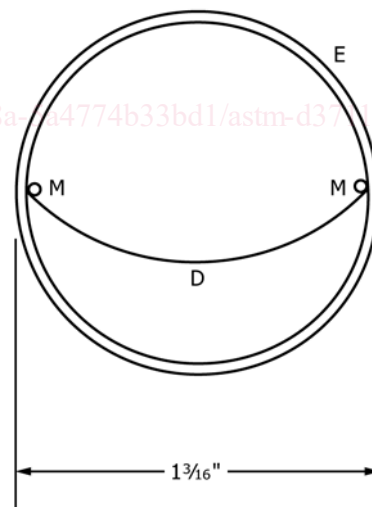

- 1 3/16 in. = 30.1 mm
- D—Metal test piece for thin liquid films
- E—Furnace liner (with standard taper male end joints)
- M—Longitudinal aligning rods

FIG. 2 Furnace Liner

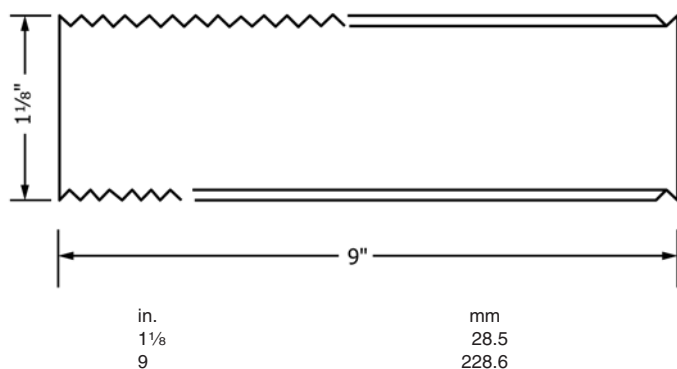

FIG. 3 Metal Test Piece Thin Film Liquid Contact

6.6 Pump, peristaltic or kinetic clamp type capable of delivering  $50 \pm 5$  mL of sample per hour.<sup>7,10</sup>

6.7 Tubing<sup>7,11</sup> for use with pump.

6.8 Steel Test Specimens—See Fig. 3.

6.9 Analytical Balance capable of measuring mass of test specimen to the nearest 0.1 mg.

## 7. Reagents and Materials

7.1 Chloroform (**Warning**—Can be fatal if swallowed. Harmful if inhaled. May produce toxic vapors if burned. See A2.1.) technical grade.

7.2 Chromic Acid Cleaning Solution (**Warning**—Causes severe burns. A recognized carcinogen. Strong oxidizer, contact with organic material can cause fire. Hygroscopic. See 2.2.)

7.3 Mild Steel Shim Stock, 0.051 mm (0.002 in.) thick.

7.4 Pentane (**Warning**—Extremely flammable. Harmful if inhaled. Vapors can cause flash fire. See A2.3.) commercial grade, conforming to the following requirements:

Distillation (Method D216):	
Initial boiling point	306.5 K (92°F)
Dry point	313.8 K (105°F)
Olefins	none
Isopentane, max, %	20
n-Pentane, min, %	80
Reid vapor pressure	117 kPa (17 psi)
(Test Method D323), max	

## 8. Sampling

8.1 The sample of test liquid shall be uncontaminated and representative of the bulk liquid as specified in Practice D4057 or Test Method D4177.

## 9. Test Specimens

9.1 One-hundred millilitres of a liquid test specimen are required for a single determination of the thin film deposit forming tendency.

<sup>10</sup> Any peristaltic pump capable of delivering the sample at the prescribed rate is satisfactory. Any tubing compatible with the sample may be used. It is recognized that, due to viscosity and compatibility phenomena, no single pump and tubing combination will be acceptable for use with all samples.

<sup>11</sup> The sole source of supply of the apparatus known to the committee at this time is Kimwipes, Type 900M, Kimberly Clark Corp., Neenah, WI, have been found satisfactory.

## 10. Procedure

10.1 Prepare a test specimen in accordance with the following procedure:

10.1.1 Buff both sides of a piece of mild steel shim stock with jewelers rouge on a cloth wheel. The direction of polishing should be the same as that of the intended liquid flow.

10.1.2 Clean the shim stock thoroughly by washing with pentane and chloroform. Allow the specimen to dry at room temperature.

10.1.3 Cut a test specimen of the proper size from the polished stock (see Fig. 3).

10.1.4 Weigh the test specimen to the nearest 0.1 mg.

10.1.4.1 In order to clean the shim stock effectively it is necessary to wipe it vigorously with a paper tissue saturated with chloroform.

10.2 Clean the glass parts of the test apparatus by washing with hot chloroform. Tenacious deposits may be removed with chromic acid cleaning solution. Rinse thoroughly with water and dry the parts completely.

10.3 Insert the clean, dry test specimen in the furnace liner and place the liner in the furnace. Place the end caps on the liner. Install new tubing in the system. Fill the sump with 100 mL of the sample to be tested.

10.4 Before connecting the pump outlet tube to the input head of the furnace liner determine that the sample flow rate is  $50 \pm 5$  mL/h. If the flow rate is not within the stated limits adjust the rate accordingly until it is correct.

10.5 Turn on the furnace and allow it to reach temperature equilibrium at the desired test temperature. Start the sample pump at the same time.

10.5.1 A test temperature of 533 K has been found to be useful for the evaluation of the thin film deposit forming characteristics of automotive crankcase oils and similar materials of petroleum origin. Synthetic materials and highly refined petroleum fluids may be tested at higher temperatures if desired.

10.6 Allow the sample to circulate from the sump, over the test specimen and back to the sump for 5 h after the furnace has reached temperature equilibrium.

10.7 After 5 h turn off the pump and remove the test specimen from the furnace liner. Carefully rinse the test specimen with three successive rinses of pentane to remove adhering sample. Dry at room temperature and weigh to the nearest 0.1 mg. Then rinse the test specimen carefully with three successive rinses of chloroform. Dry at room temperature and weigh to the nearest 0.1 mg. Wipe the test specimen vigorously in the longitudinal direction with a piece of laboratory tissue to remove loose deposits. Weigh the test specimen to the nearest 0.1 mg.

10.7.1 Test periods longer or shorter than 5 h may be used provided that their use is noted in the report of test results.

10.7.2 Rinse the test specimen by immersion in the solvents. A spray of solvent from a wash bottle shall not be used, since it may cause the loss of loosely adhering deposits. Take care to avoid undue flexing of the exposed test specimen as this can also cause the loss of some of the deposit.