Metallic materials — Bend test

Matériaux métalliques — Essai de pliage

iTeh Standards
(<https://standards.iteh.ai>)
Document Preview

[ISO 7438:2020](https://standards.iteh.ai/catalog/standards/iso/b3f3b8b3-b9e1-4c92-ae7c-c3ed77b61527/iso-7438-2020)

<https://standards.iteh.ai/catalog/standards/iso/b3f3b8b3-b9e1-4c92-ae7c-c3ed77b61527/iso-7438-2020>



iTeh Standards
(<https://standards.iteh.ai>)
Document Preview

ISO 7438:2020

<https://standards.iteh.ai/catalog/standards/iso/b3f3b8b3-b9e1-4c92-ae7c-c3ed77b61527/iso-7438-2020>



COPYRIGHT PROTECTED DOCUMENT

© ISO 2020

All rights reserved. Unless otherwise specified, or required in the context of its implementation, no part of this publication may be reproduced or utilized otherwise in any form or by any means, electronic or mechanical, including photocopying, or posting on the internet or an intranet, without prior written permission. Permission can be requested from either ISO at the address below or ISO's member body in the country of the requester.

ISO copyright office
CP 401 • Ch. de Blandonnet 8
CH-1214 Vernier, Geneva
Phone: +41 22 749 01 11
Email: copyright@iso.org
Website: www.iso.org

Published in Switzerland

Contents

Page

Foreword.....	iv
1 Scope.....	1
2 Normative references.....	1
3 Terms and definitions.....	1
4 Symbols, designations and units.....	1
5 Principle.....	2
6 Test equipment.....	2
6.1 General.....	2
6.2 Bending device with supports and a former.....	4
6.3 Bending device with a V-block.....	4
6.4 Bending device with a clamp.....	4
7 Test piece.....	4
7.1 General.....	4
7.2 Edges of rectangular test pieces.....	4
7.3 Width of the test piece.....	5
7.4 Thickness of the test piece.....	5
7.5 Test pieces from forgings, castings and semi-finished products.....	5
7.6 Agreement for test pieces of greater thickness and width.....	5
7.7 Length of the test piece.....	5
8 Procedure.....	6
9 Interpretation of results.....	7
10 Test report.....	7
Annex A (informative) Determination of the bend angle from the measurement of the displacement of the former.....	8
Annex B (normative) Bend test at plane strain conditions.....	9
Bibliography.....	13

Foreword

ISO (the International Organization for Standardization) is a worldwide federation of national standards bodies (ISO member bodies). The work of preparing International Standards is normally carried out through ISO technical committees. Each member body interested in a subject for which a technical committee has been established has the right to be represented on that committee. International organizations, governmental and non-governmental, in liaison with ISO, also take part in the work. ISO collaborates closely with the International Electrotechnical Commission (IEC) on all matters of electrotechnical standardization.

The procedures used to develop this document and those intended for its further maintenance are described in the ISO/IEC Directives, Part 1. In particular, the different approval criteria needed for the different types of ISO documents should be noted. This document was drafted in accordance with the editorial rules of the ISO/IEC Directives, Part 2 (see www.iso.org/directives).

Attention is drawn to the possibility that some of the elements of this document may be the subject of patent rights. ISO shall not be held responsible for identifying any or all such patent rights. Details of any patent rights identified during the development of the document will be in the Introduction and/or on the ISO list of patent declarations received (see www.iso.org/patents).

Any trade name used in this document is information given for the convenience of users and does not constitute an endorsement.

For an explanation of the voluntary nature of standards, the meaning of ISO specific terms and expressions related to conformity assessment, as well as information about ISO's adherence to the World Trade Organization (WTO) principles in the Technical Barriers to Trade (TBT), see www.iso.org/iso/foreword.html.

This document was prepared by Technical Committee ISO/TC 164, *Mechanical testing of metals*, Subcommittee SC 2, *Ductility testing*, in collaboration with the European Committee for Standardization (CEN) Technical Committee CEN/TC 459, *ECISS – European Committee for Iron and Steel Standardization*, in accordance with the Agreement on technical cooperation between ISO and CEN (Vienna Agreement).

This fourth edition cancels and replaces the third edition (ISO 7438:2016), which has been technically revised.

The main change compared to the previous edition is the addition of new [Annex B](#), describing bending test at plane strain condition.

Any feedback or questions on this document should be directed to the user's national standards body. A complete listing of these bodies can be found at www.iso.org/members.html.

Metallic materials — Bend test

1 Scope

This document specifies a method for determining the ability of metallic materials to undergo plastic deformation in bending.

This document applies to test pieces taken from metallic products, as specified in the relevant product standard. It is not applicable to certain materials or products, for example tubes in full section or welded joints, for which other standards exist.

2 Normative references

There are no normative references in this document.

3 Terms and definitions

No terms and definitions are listed in this document.

ISO and IEC maintain terminological databases for use in standardization at the following addresses:

- IEC Electropedia: available at <http://www.electropedia.org/>
- ISO Online browsing platform: available at <https://www.iso.org/obp>

4 Symbols, designations and units

Symbols and designations used in the bend test are shown in [Figures 1](#) and [2](#) and specified in [Table 1](#).

Table 1 — Symbols, designations and units

Symbol	Designation	Unit
a	Thickness or diameter of test piece (or diameter of the inscribed circle for pieces of polygonal cross-section)	mm
b	Width of the test piece	mm
c	Distance between the plane including the horizontal axis of supports and the central axis of the rounded portion of the former before test	mm
D	Diameter of the former	mm
f	Displacement of the former	mm
$\bar{\theta}$	Lode angle parameter, i.e. strain path direction	—
L	Length of the test piece	mm
l	Distance between supports	mm
η	Triaxiality factor	—
p	Distance between the vertical planes including the central axis of each support and the vertical plane including the central axis of the former	mm
R	Radius of the supports	mm
r	Internal radius of bend portion of test piece after bending	mm
α	Angle of bend	degrees

5 Principle

The bend test consists of submitting a test piece of round, square, rectangular or polygonal cross-section to plastic deformation by bending, without changing the direction of loading, until a specified angle of bend is reached.

The axes of two legs of the test piece remain in a plane perpendicular to the axis of bending. In the case of a 180° bend, the two lateral surfaces may, depending on the requirements of the product standard, lie flat against each other or can be parallel at a specified distance, an insert being used to control this distance.

6 Test equipment

6.1 General

The bend test shall be carried out in testing machines or presses equipped with the following devices:

- a) bending device with two supports and a former as shown in [Figure 1](#);
- b) bending device with a V-block and a former as shown in [Figure 2](#);
- c) bending device with a clamp as shown in [Figure 3](#).

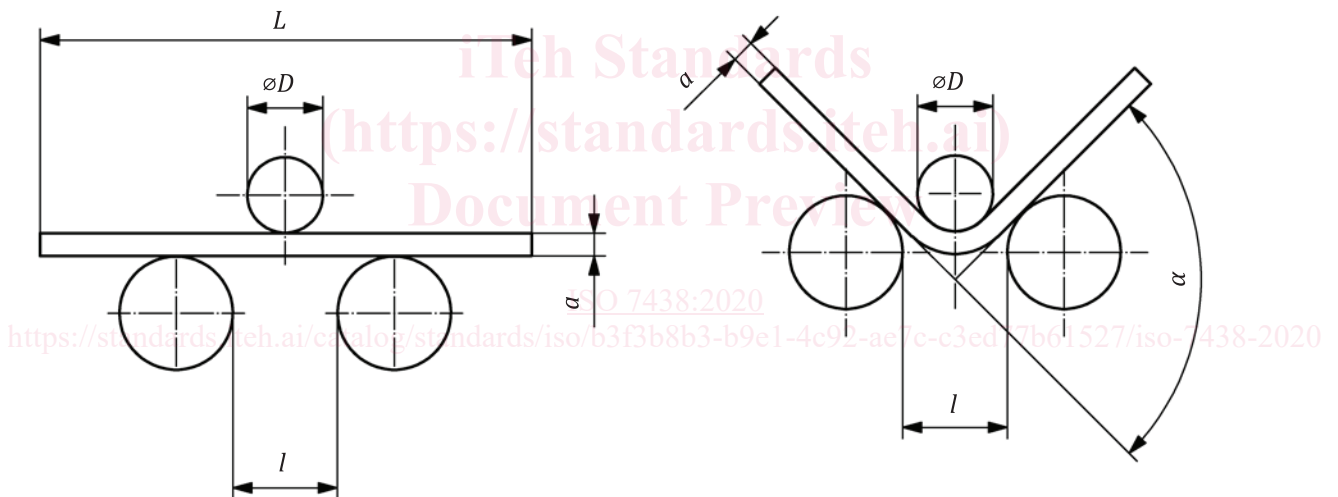

Figure 1 — Bending device with two supports and a former