**Protective equipment for martial
arts —**

**Part 3:
Additional requirements and test
methods for trunk protectors**

iTeh STANDARD PREVIEW
Équipement de protection pour les arts martiaux —
(standards.iteh.ai) **Partie 3: Exigences et méthodes d'essai complémentaires relatives aux**
protège-torses

ISO 21924-3:2017

<https://standards.iteh.ai/catalog/standards/sist/6c505bb5-6751-4283-be7a-1002a35988a2/iso-21924-3-2017>



iTeh STANDARD PREVIEW
(standards.iteh.ai)

ISO 21924-3:2017

<https://standards.iteh.ai/catalog/standards/sist/6c505bb5-6751-4283-be7a-1002a35988a2/iso-21924-3-2017>



COPYRIGHT PROTECTED DOCUMENT

© ISO 2017, Published in Switzerland

All rights reserved. Unless otherwise specified, no part of this publication may be reproduced or utilized otherwise in any form or by any means, electronic or mechanical, including photocopying, or posting on the internet or an intranet, without prior written permission. Permission can be requested from either ISO at the address below or ISO's member body in the country of the requester.

ISO copyright office
Ch. de Blandonnet 8 • CP 401
CH-1214 Vernier, Geneva, Switzerland
Tel. +41 22 749 01 11
Fax +41 22 749 09 47
copyright@iso.org
www.iso.org

Contents

	Page
Foreword	iv
1 Scope	1
2 Normative references	1
3 Terms and definitions	1
4 Requirements	1
4.1 Sizing	1
4.2 Combinations	1
4.3 Restraint	2
4.4 Zone of protection	2
4.5 Impact performance	2
4.6 Mass and thickness for trunk protectors for karate	3
5 Testing	3
5.1 Sampling	3
5.2 Conditioning	3
5.3 Restraint	3
5.4 Zone of protection	3
5.5 Impact performance	4
5.5.1 Apparatus	4
5.5.2 Procedure	4
6 Marking	5
7 Information supplied by the manufacturer	5

<https://standards.iteh.ai/catalog/standards/sist/6c505bb5-6751-4283-be7a-1002a35988a2/iso-21924-3-2017>

Foreword

ISO (the International Organization for Standardization) is a worldwide federation of national standards bodies (ISO member bodies). The work of preparing International Standards is normally carried out through ISO technical committees. Each member body interested in a subject for which a technical committee has been established has the right to be represented on that committee. International organizations, governmental and non-governmental, in liaison with ISO, also take part in the work. ISO collaborates closely with the International Electrotechnical Commission (IEC) on all matters of electrotechnical standardization.

The procedures used to develop this document and those intended for its further maintenance are described in the ISO/IEC Directives, Part 1. In particular the different approval criteria needed for the different types of ISO documents should be noted. This document was drafted in accordance with the editorial rules of the ISO/IEC Directives, Part 2 (see www.iso.org/directives).

Attention is drawn to the possibility that some of the elements of this document may be the subject of patent rights. ISO shall not be held responsible for identifying any or all such patent rights. Details of any patent rights identified during the development of the document will be in the Introduction and/or on the ISO list of patent declarations received (see www.iso.org/patents).

Any trade name used in this document is information given for the convenience of users and does not constitute an endorsement.

For an explanation on the voluntary nature of standards, the meaning of ISO specific terms and expressions related to conformity assessment, as well as information about ISO's adherence to the World Trade Organization (WTO) principles in the Technical Barriers to Trade (TBT) see the following URL: www.iso.org/iso/foreword.html. (standards.iteh.ai)

This document was prepared by Technical Committee ISO/TC 83, *Sports and other recreational facilities and equipment*, Subcommittee SC 6, *Martial arts*. ISO 21924-3:2017

<https://standards.iteh.ai/catalog/standards/sist/6c505bb5-6751-4283-be7a-190b3c988d6c-iso-21924-3-2017>

A list of all parts in the ISO 21924 series can be found on the ISO website.

Protective equipment for martial arts —

Part 3: Additional requirements and test methods for trunk protectors

1 Scope

This document specifies additional requirements and test methods for trunk protectors used in unarmed martial arts such as taekwondo, karate, kick-boxing and similar disciplines.

It also applies to breast protectors for men.

For general requirements and test methods for protective equipment for martial arts, see ISO 21924-1.

2 Normative references

The following documents are referred to in the text in such a way that some or all of their content constitutes requirements of this document. For dated references, only the edition cited applies. For undated references, the latest edition of the referenced document (including any amendments) applies.

ISO 21924-1:2017, *Protective equipment for martial arts — Part 1: General requirements and test methods*

ISO 21924-3:2017

3 Terms and definitions

<http://standards.iteh.ai/catalog/standards/sist/6c505bb5-6751-4283-be7a-1002a35988a2/iso-21924-3-2017>

For the purposes of this document, the terms and definitions given in ISO 21924-1 apply.

ISO and IEC maintain terminological databases for use in standardization at the following addresses:

- ISO Online browsing platform: available at <http://www.iso.org/obp>
- IEC Electropedia: available at <http://www.electropedia.org/>

4 Requirements

4.1 Sizing

The manufacturer shall indicate in centimetres the range of the wearer's height for which this protector is designed.

4.2 Combinations

Trunk protectors can be used in combination with other protectors for martial arts.

In the case of combined use, the requirements specified for the individual protectors are also to apply.

Possible combinations shall be indicated in the information supplied by the manufacturer.

If combined use is not permitted by the manufacturer, this restriction shall be indicated in the information supplied by the manufacturer.

4.3 Restraint

A restraint system shall be supplied by the manufacturer which enables the user to attach trunk protectors with the support of no more than one assistant.

For karate, the fixing systems shall be only textiles. They shall never consist of metal, plastic or similar hard materials.

4.4 Zone of protection

For location and dimensions of the zone of protection, see [Figure 1](#) and [Table 1](#).

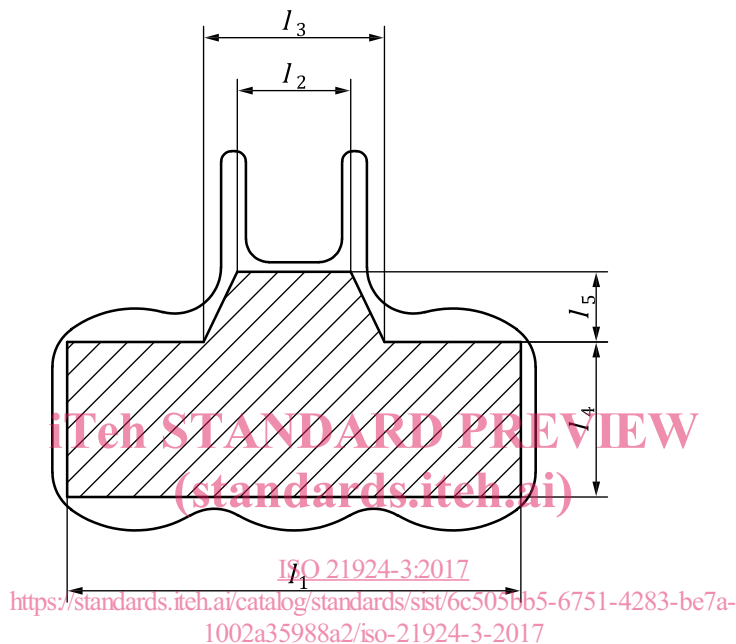

Figure 1 — Location of the zone of protection of trunk protectors

Table 1 — Zone of protection of trunk protectors

Dimensions in millimetres

Wearer's height	l_1 min.	l_2 min.	l_3 min.	l_4 min.	l_5 min.
<1 340	610	140	170	150	90
1 340 to 1 520	660	150	190	160	100
>1 520 to 1 700	710	160	210	175	110
>1 700 to 1 880	760	180	230	190	130
>1 880	810	200	250	210	150

4.5 Impact performance

Trunk protectors comply with this document if the worst result after testing in accordance with [5.5](#) meets the following requirements:

- impact energy: 12 J;
- impact energy for karate: 2,6 J;
- peak force: max. 3 kN;
- positions to be tested: min. 3.

4.6 Mass and thickness for trunk protectors for karate

For any size of trunk protectors for karate, the total mass shall not exceed 250 g.

For any size of trunk protectors for karate, the thickness shall not exceed 15 mm.

5 Testing

5.1 Sampling

Sampling shall be carried out according to ISO 21924-1:2017, 5.1.

5.2 Conditioning

Conditioning shall be carried out according to ISO 21924-1:2017, 5.2.

5.3 Restraint

Restraint testing shall be carried out according to ISO 21924-1:2017, 5.4. When testing the restraint, the protector shall be attached to the trunk of a test person of an appropriate height in accordance with the information supplied by the manufacturer.

A test force of 50 N shall be applied at the edge of the zone of protection, in the directions and in the order shown on [Figure 2](#), tangential to the surface of the body of the test person.

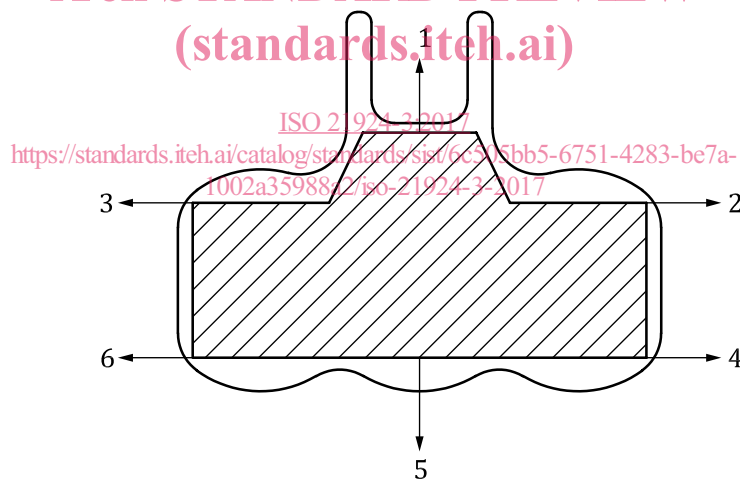

Key

1 to 6 directions and order of the tests

Figure 2 — Restraint test of trunk protectors

5.4 Zone of protection

When testing according to ISO 21924-1:2017, 5.5, the protector shall be attached to a test person of an appropriate height in accordance with the information supplied by the manufacturer.

The gauge shall be placed onto the surface of the zone of protection.

When the position of the best coverage of the gauge is found, the outline of the gauge shall be marked on the protector.

5.5 Impact performance

5.5.1 Apparatus

The principle of impact testing is shown in [Figure 3](#).

5.5.1.1 Flat horizontal steel plate, with a width of at least 300 mm, a length of at least 350 mm and a thickness of at least 20 mm shall be used as a support of the sample. In the centre of the flat plate, there shall be a cylindrical hole with a diameter of (106 ± 2) mm.

5.5.1.2 Cylindrical anvil, with a diameter of (100 ± 2) mm, a thickness of at least 20 mm with a flat upper surface shall be mounted on a load cell.

The surface of the anvil facing the striker shall be in level with the surface of the flat plate with a tolerance of ± 1 mm.

5.5.1.3 Compression ring, made of steel with a mass of $(10 \pm 0,1)$ kg, $(140 \pm 0,1)$ mm internal and (260 ± 4) mm external diameter shall be used to fix the sample to the support.

5.5.1.4 Striker shall be able to fall free in the vertical axis of the anvil with a tolerance of ± 2 mm. The striker shall be guided in such a way that it will always reach at least 95 % of the freefall velocity. A means of measuring the velocity of the striker at the point of impact shall be provided.

To measure the maximum peak force, an electronic measurement device with the following characteristics shall be used:

- measurement frequency: minimum 2 000 Hz,
- accuracy class of the load cell: 0,2;
- maximum load: 10 kN.

ITeH STANDARD PREVIEW
(standards.iteh.ai)
<https://standards.iteh.ai/catalog/standards/sist/6c505bb5-6751-4283-be7a-1002a35988a2/iso-21924-3-2017>

5.5.2 Procedure

The trunk protector shall be placed on the flat support so that the test positions to be tested shall be above the centre of the anvil and shall be fixed with the compression ring.

The compression ring shall be placed so that the anvil is situated in the centre of the ring with a tolerance of ± 5 mm.

The trunk protector shall be moved on the support in order to reach every test position to be tested.

If it is not possible to press the trunk protector flat with the compression ring, the protector shall be cut, until it is possible to place it flat.

The test positions shall be selected so that they are not closer than 20 mm to the limit of the zone of protection. If the test position is closer to the edge of the zone of protection than 70 mm, and there is a gap between the protector and the compression ring, a part of the same protector or of another protector of the same construction shall be cut and placed in the gap.

The test positions shall be selected to include the positions on the protector where the worst test results are assumed to be likely.

Three impacts of the same energy level shall be carried out on each test position with an interval of (60 ± 10) s.

No other test position previously tested shall be within a circle of 80 mm around the test position to be tested. If positions are selected to be impacted less than 80 mm distant from each other, at least two protectors of the same type shall be selected for impact testing.

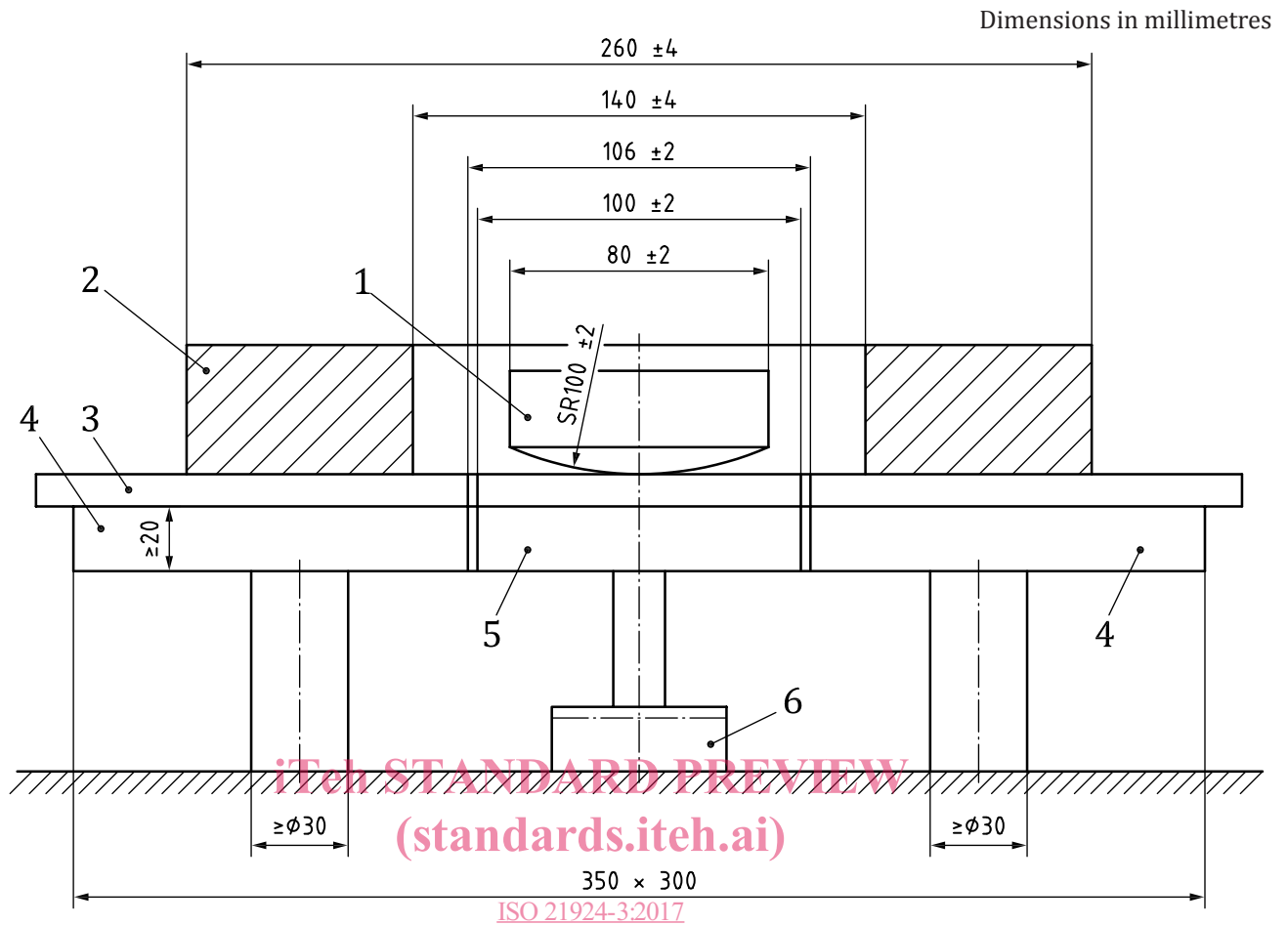
**Key**

- 1 striker
- 2 compression ring
- 3 trunk protector
- 4 steel plate
- 5 anvil
- 6 load cell

Figure 3 — Principle of impact testing of trunk protectors

6 Marking

Marking shall be carried out in accordance with ISO 21924-1:2017, Clause 6. Additionally, the karate trunk protectors shall be marked with an indication that they shall only be used for karate.

7 Information supplied by the manufacturer

Requirements for the information to be supplied by the manufacturer shall be in accordance with ISO 21924-1:2017, Clause 7.