Structures for mine shafts —

**Part 1:
Vocabulary**

Structures de puits de mine —

Partie 1: Vocabulaire

**iTeh STANDARD PREVIEW
(standards.iteh.ai)**

ISO 19426-1:2018

<https://standards.iteh.ai/catalog/standards/sist/e513349c-6551-42b1-bbd5-6e81df5b8fbf/iso-19426-1-2018>



iTeh STANDARD PREVIEW
(standards.iteh.ai)

ISO 19426-1:2018

<https://standards.iteh.ai/catalog/standards/sist/e513349c-6551-42b1-bbd5-6e81df5b8fbf/iso-19426-1-2018>



COPYRIGHT PROTECTED DOCUMENT

© ISO 2018

All rights reserved. Unless otherwise specified, or required in the context of its implementation, no part of this publication may be reproduced or utilized otherwise in any form or by any means, electronic or mechanical, including photocopying, or posting on the internet or an intranet, without prior written permission. Permission can be requested from either ISO at the address below or ISO's member body in the country of the requester.

ISO copyright office
CP 401 • Ch. de Blandonnet 8
CH-1214 Vernier, Geneva
Phone: +41 22 749 01 11
Fax: +41 22 749 09 47
Email: copyright@iso.org
Website: www.iso.org

Published in Switzerland

Contents

	Page
Foreword.....	iv
Introduction.....	v
1 Scope.....	1
2 Normative references.....	1
3 Terms and definitions.....	1
Bibliography.....	13

iTeh STANDARD PREVIEW **(standards.iteh.ai)**

ISO 19426-1:2018

<https://standards.iteh.ai/catalog/standards/sist/e513349c-6551-42b1-bbd5-6e81df5b8fbf/iso-19426-1-2018>

Foreword

ISO (the International Organization for Standardization) is a worldwide federation of national standards bodies (ISO member bodies). The work of preparing International Standards is normally carried out through ISO technical committees. Each member body interested in a subject for which a technical committee has been established has the right to be represented on that committee. International organizations, governmental and non-governmental, in liaison with ISO, also take part in the work. ISO collaborates closely with the International Electrotechnical Commission (IEC) on all matters of electrotechnical standardization.

The procedures used to develop this document and those intended for its further maintenance are described in the ISO/IEC Directives, Part 1. In particular the different approval criteria needed for the different types of ISO documents should be noted. This document was drafted in accordance with the editorial rules of the ISO/IEC Directives, Part 2 (see www.iso.org/directives).

Attention is drawn to the possibility that some of the elements of this document may be the subject of patent rights. ISO shall not be held responsible for identifying any or all such patent rights. Details of any patent rights identified during the development of the document will be in the Introduction and/or on the ISO list of patent declarations received (see www.iso.org/patents).

Any trade name used in this document is information given for the convenience of users and does not constitute an endorsement.

For an explanation on the voluntary nature of standards, the meaning of ISO specific terms and expressions related to conformity assessment, as well as information about ISO's adherence to the World Trade Organization (WTO) principles in the Technical Barriers to Trade (TBT) see the following URL: www.iso.org/iso/foreword.html. (standards.iteh.ai)

This document was prepared by Technical Committee ISO/TC 82, *Mining*.

A list of all parts in the ISO 19426 series can be found on the ISO website. www.iso.org/iso/19426-1-42b1-bbd5-6e81df5b8bf/iso-19426-1-2018

Introduction

Many mining companies, and many of the engineering companies that provide designs for mines, operate globally so ISO 19426 was developed in response to a desire for a unified global approach to the safe and robust design of structures for mine shafts. The characteristics of ore bodies, such as their depth and shape, vary in different areas so different design approaches have been developed and proven with use over time in different countries. Bringing these approaches together in ISO 19426 will facilitate improved safety and operational reliability.

The majority of the material in ISO 19426 deals with the loads to be applied in the design of structures for mine shafts. Some principles for structural design are given, but for the most part it is assumed that local standards will be used for the structural design.

iTeh STANDARD PREVIEW (standards.iteh.ai)

[ISO 19426-1:2018](https://standards.iteh.ai/catalog/standards/sist/e513349c-6551-42b1-bbd5-6e81df5b8bf/iso-19426-1-2018)

<https://standards.iteh.ai/catalog/standards/sist/e513349c-6551-42b1-bbd5-6e81df5b8bf/iso-19426-1-2018>

iTeh STANDARD PREVIEW
(standards.iteh.ai)

ISO 19426-1:2018

<https://standards.iteh.ai/catalog/standards/sist/e513349c-6551-42b1-bbd5-6e81df5b8bf/iso-19426-1-2018>

Structures for mine shafts —

Part 1: Vocabulary

1 Scope

This document specifies the terms and definitions related to the structures for mine shafts, used throughout ISO 19426.

Terms used in mining can vary from conventional engineering usage, and they vary quite considerably between different countries. For this reason, alternative terms are provided in many of the entries. The preferred terms, given in bold type, are those used throughout ISO 19426.

It is assumed that users of this document are familiar with mining, so common terms with normal dictionary usage are not defined. Also, no definitions are provided for terms that can be widely used in mining but are not explicitly used in ISO 19426.

2 Normative references

The following documents are referred to in the text in such a way that some or all of their content constitutes requirements of this document. For dated references, only the edition cited applies. For undated references, the latest edition of the referenced document (including any amendments) applies.

There are no normative references in this document.

3 Terms and definitions

ISO and IEC maintain terminological databases for use in standardization at the following addresses:

- ISO Online browsing platform: available at <http://www.iso.org/obp>
- IEC Electropedia : available at <http://www.electropedia.org>

3.1

bank level

shaft collar
top of the shaft

3.2

bank door

collar door
shaft door
door installed at *bank level* (3.1) that prevents personnel, equipment and material from falling down the shaft

3.3

bottom transom

structural member, or group of members, located at the bottom of the *bridle* (3.7) and used to transfer *underslung loads* (3.85) or tail-rope loads to the *bridle hangers* (3.8)

Note 1 to entry: See [Figures 1, 2](#) and [3](#).

3.4

box front

gate

structure located at the lower end of a *rock pass* (3.62) used to control *rock* (3.61) flow

3.5

brattice screen

screen to partition off a portion of the shaft to prevent falling objects or spillage moving from one area of the shaft to another

Note 1 to entry: This is usually placed around personnel hoisting compartments to ensure safe hoisting conditions.

3.6

brattice wall

airtight dividing wall partitioning a shaft into two distinct ventilation compartments, one being an upcast compartment and the other a downcast compartment

3.7

bridle

structural frame that includes the *top transom* (3.81), the *bottom transom* (3.3) and the *bridle hangers* (3.8) to form a frame that carries the *cage* (3.11) or *skip* (3.73) body

Note 1 to entry: See [Figures 1, 2](#) and [3](#).

3.8

bridle hanger

structural member, or group of members, that transfers loads between the *top transom* (3.81) and *bottom transom* (3.3)

Note 1 to entry: See [Figures 1, 2](#) and [3](#).

iTeh STANDARD PREVIEW
(standards.iteh.ai)

ISO 19426-1:2018

<https://standards.iteh.ai/catalog/standards/sist/e513349c-6551-42b1-bbd5-6e81d5b8bf/iso-19426-1-2018>

3.9

brow beam

beam that supports the concrete layer that stabilizes the hanging wall at a station

3.10

bunton

structural member (usually horizontal) that primarily provides support to the *conveyance* (3.15) *guides* (3.38)

3.11

cage

single or multiple deck *conveyance* (3.15) used for the transportation of personnel, equipment or material (or both) in the shaft

Note 1 to entry: See [Figure 1](#).

3.12

camelback

raised portion of the path traversed by a roller, used for tipping hoppers in *decline shafts* (3.21) or for providing a gravity locking mechanism on *skips* (3.73) in vertical shafts

3.13

canopy

cover or roof structure, offering protection to persons on the top deck of the *stage* (3.75) or on a *conveyance* (3.15)

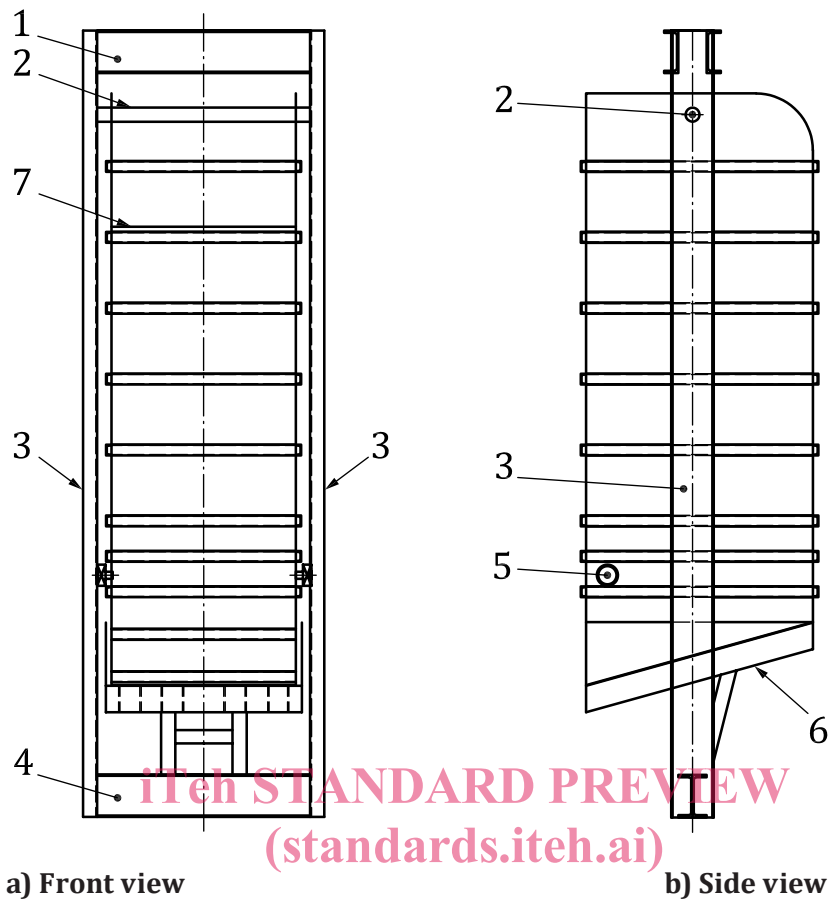

a) Front view

b) Side view

Key

- 1 top transom (3.81)
- 2 pivot bar
- 3 bridle hanger (3.8)
- 4 bottom transom (3.3)

ISO 19426-1:2018
<https://standards.itech.ai/catalog/standards/sist/e513349c-6551-42b1-bbd5-6e81df5b8fb7/iso-19426-1-2018>

- 5 tipping roller
- 6 door
- 7 loading lip

Figure 2 — Typical skip components

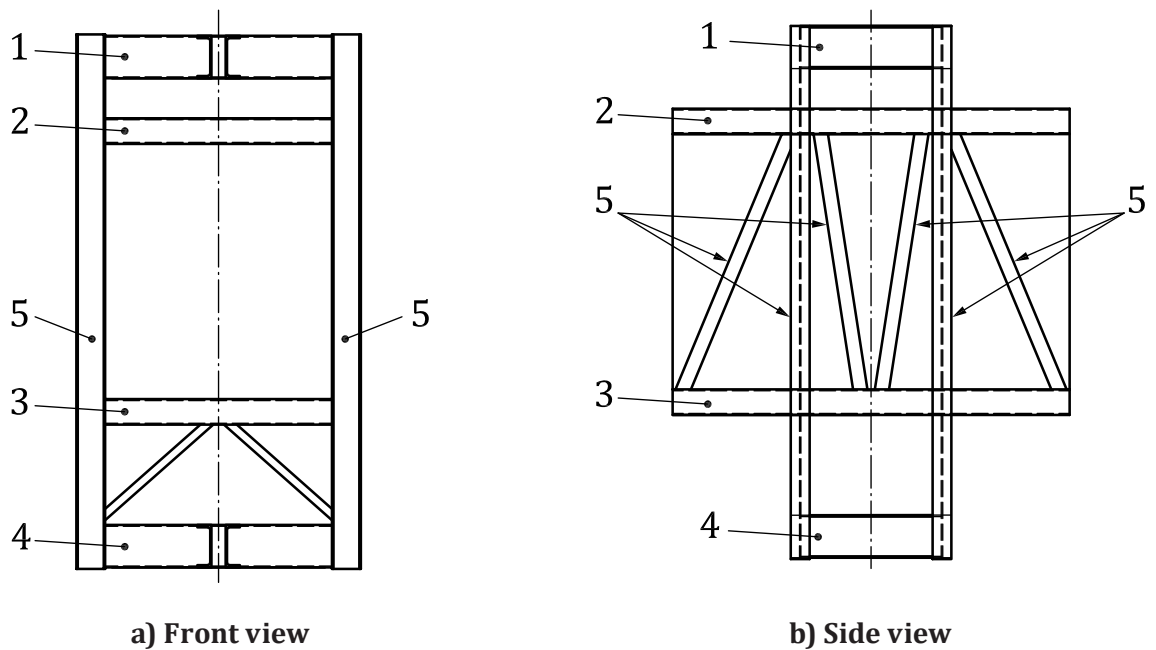
**Key**

- | | | | |
|---|--------------------|---|----------------------|
| 1 | top transom (3.81) | 4 | bottom transom (3.3) |
| 2 | roof beam | 5 | bridle hanger (3.8) |
| 3 | floor beam | | |

iTeh STANDARD PREVIEW
(standards.iteh.ai)

Figure 3 — Typical single deck cage components

ISO 19426-1:2018

<https://standards.iteh.ai/catalog/standards/sist/e513349c-6551-42b1-bbd5-6e81df5b8fbf/iso-19426-1-2018>

3.16 control conveyance

pilot car

conveyance (3.15) in a *decline shaft* (3.21), attached to the haulage rope or the *winding rope* (3.88), that can contain an operator who is in communication with the haulage engine or *winder* (3.87) and that controls the operation of the train

3.17 counterweight

balance mass in a *conveyance* (3.15) winding system

3.18 crash beam

beam intended to stop the *conveyance* (3.15) in the event of a final *overwind* (3.56)

3.19 critical load bearing component

structural components, failure of which would be catastrophic

Note 1 to entry: For *conveyances* (3.15), this includes all *top transoms* (3.81) and *bottom transoms* (3.3), *bridle hangers* (3.8), floor beams and their immediate connecting elements.

3.20 cross beam

beam spanning between the *shaft walls* (3.69) for the purposes of suspending a *stage* (3.75)