**Assembly tools for screws and nuts —
Ratcheting wrenches — Technical
requirements**

*Outils de manoeuvre pour vis et écrous — Clé à cliquet — Exigences
techniques*

iTeh STANDARD PREVIEW
(standards.iteh.ai)

[ISO 21982:2020](https://standards.iteh.ai/catalog/standards/sist/5f852219-d901-4b21-8883-b364902e5a59/iso-21982-2020)

[https://standards.iteh.ai/catalog/standards/sist/5f852219-d901-4b21-8883-
b364902e5a59/iso-21982-2020](https://standards.iteh.ai/catalog/standards/sist/5f852219-d901-4b21-8883-b364902e5a59/iso-21982-2020)



iTeh STANDARD PREVIEW
(standards.iteh.ai)

ISO 21982:2020

<https://standards.iteh.ai/catalog/standards/sist/5f852219-d901-4b21-8883-b364902e5a59/iso-21982-2020>



COPYRIGHT PROTECTED DOCUMENT

© ISO 2020

All rights reserved. Unless otherwise specified, or required in the context of its implementation, no part of this publication may be reproduced or utilized otherwise in any form or by any means, electronic or mechanical, including photocopying, or posting on the internet or an intranet, without prior written permission. Permission can be requested from either ISO at the address below or ISO's member body in the country of the requester.

ISO copyright office
CP 401 • Ch. de Blandonnet 8
CH-1214 Vernier, Geneva
Phone: +41 22 749 01 11
Email: copyright@iso.org
Website: www.iso.org

Published in Switzerland

Contents

	Page
Foreword	iv
1 Scope	1
2 Normative references	1
3 Terms and definitions	1
4 Classification	2
5 Dimension	5
5.1 Dimensions of combination wrenches, ratcheting	5
5.2 Dimensions of double-headed box wrenches, ratcheting	6
6 Hardness	7
7 Reversing torque testing	8
8 Torque testing	8
9 Drop testing	8
10 Function	8
11 Cycle testing	8
12 Test sequence	9
13 Designation	9
14 Marking	9
Annex A (informative) Recommended combinations	10
Bibliography	11

iTeh STANDARD PREVIEW

(standards.iteh.ai)

[ISO 21982:2020](https://standards.iteh.ai/catalog/standards/sist/5f852219-d901-4b21-8883-b364902e5a59/iso-21982-2020)

<https://standards.iteh.ai/catalog/standards/sist/5f852219-d901-4b21-8883-b364902e5a59/iso-21982-2020>

Foreword

ISO (the International Organization for Standardization) is a worldwide federation of national standards bodies (ISO member bodies). The work of preparing International Standards is normally carried out through ISO technical committees. Each member body interested in a subject for which a technical committee has been established has the right to be represented on that committee. International organizations, governmental and non-governmental, in liaison with ISO, also take part in the work. ISO collaborates closely with the International Electrotechnical Commission (IEC) on all matters of electrotechnical standardization.

The procedures used to develop this document and those intended for its further maintenance are described in the ISO/IEC Directives, Part 1. In particular, the different approval criteria needed for the different types of ISO documents should be noted. This document was drafted in accordance with the editorial rules of the ISO/IEC Directives, Part 2 (see www.iso.org/directives).

Attention is drawn to the possibility that some of the elements of this document may be the subject of patent rights. ISO shall not be held responsible for identifying any or all such patent rights. Details of any patent rights identified during the development of the document will be in the Introduction and/or on the ISO list of patent declarations received (see www.iso.org/patents).

Any trade name used in this document is information given for the convenience of users and does not constitute an endorsement.

For an explanation of the voluntary nature of standards, the meaning of ISO specific terms and expressions related to conformity assessment, as well as information about ISO's adherence to the World Trade Organization (WTO) principles in the Technical Barriers to Trade (TBT), see www.iso.org/iso/foreword.html.

This document was prepared by Technical Committee ISO/TC 29, *Small tools*, Subcommittee SC 10, *Assembly tools for screws and nuts, pliers and nippers*.

Any feedback or questions on this document should be directed to the user's national standards body. A complete listing of these bodies can be found at www.iso.org/members.html.

Assembly tools for screws and nuts — Ratcheting wrenches — Technical requirements

1 Scope

This document specifies the dimensions and technical requirements for ratcheting wrenches used in assembly or disassembly of hexagonal and double hexagonal fasteners.

NOTE The wrenches covered by this document are the ones identified in ISO 1703 under reference No.1 1 01 07 0, 1 1 01 08 0, 1 1 01 09 0 and 1 1 02 19 0, 1 1 02 20 0.

NOTE The wrenches according to this document are not intended for uses with impact stress of the wrench.

2 Normative references

The following documents are referred to in the text in such a way that some or all of their content constitutes requirements of this document. For dated references, only the edition cited applies. For undated references, the latest edition of the referenced document (including any amendments) applies.

ISO 691, *Assembly tools for screws and nuts — Wrench and socket openings — Tolerances for general use*

ISO 1711-1:2019, *Assembly tools for screws and nuts — Technical specifications — Part 1: Hand-operated wrenches and sockets*

ISO 3318, *Assembly tools for screws and nuts — Open-ended wrenches, box wrenches and combination wrenches — Maximum widths of heads*

ISO 6507-1, *Metallic materials — Vickers hardness test — Part 1: Test method*

ISO 6508-1, *Metallic materials — Rockwell hardness test — Part 1: Test method*

ISO 7738, *Assembly tools for screws and nuts — Combination wrenches — Lengths of wrenches and maximum thickness of heads*

3 Terms and definitions

For the purposes of this document, the following terms and definitions apply.

ISO and IEC maintain terminological databases for use in standardization at the following addresses:

- ISO Online browsing platform: available at <https://www.iso.org/obp>
- IEC Electropedia: available at <http://www.electropedia.org/>

3.1

reversing torque

torque required to rotate the box-head ratchet of the wrench in the opposite direction to the direction of torque application

3.2

reversing device

part of a reversible ratchet that allows the direction of torque application to be changed by the movement of a lever or similar

4 Classification

Ratcheting wrenches to which this document applies are classified as combination wrenches, ratcheting and double-headed box wrenches, ratcheting (for recommended combinations of the wrench structures, see [Annex A](#)).

- a) Combination wrenches, ratcheting (Type I, see [Figure 1](#)):
 - 1) Class A: flat shape;
 - 2) Class B: offset shape with reversing device;
 - 3) Class C: flat shape with flexible head;
- b) Double-headed box wrenches, ratcheting (Type II, see [Figure 2](#)):
 - 1) Class A: flat shape;
 - 2) Class B: offset shape with reversing device;
 - 3) Class C: flat shape with flexible head.

NOTE [Figures 1](#) and [2](#) show only examples and do not influence the design of the wrench.

iTeh STANDARD PREVIEW
(standards.iteh.ai)

[ISO 21982:2020](https://standards.iteh.ai/catalog/standards/sist/5f852219-d901-4b21-8883-b364902e5a59/iso-21982-2020)
<https://standards.iteh.ai/catalog/standards/sist/5f852219-d901-4b21-8883-b364902e5a59/iso-21982-2020>

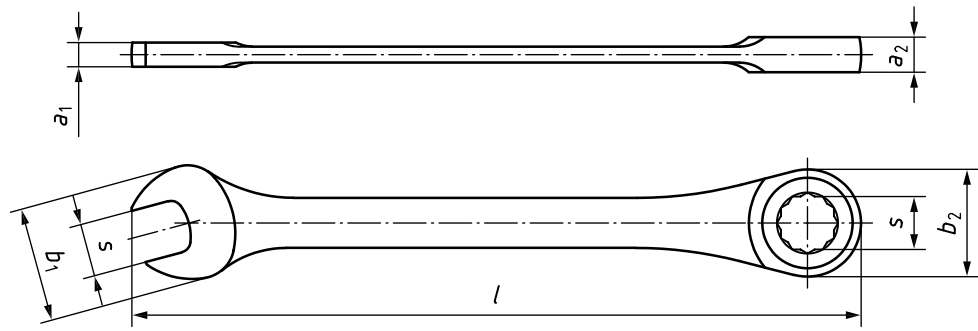

a) Class A

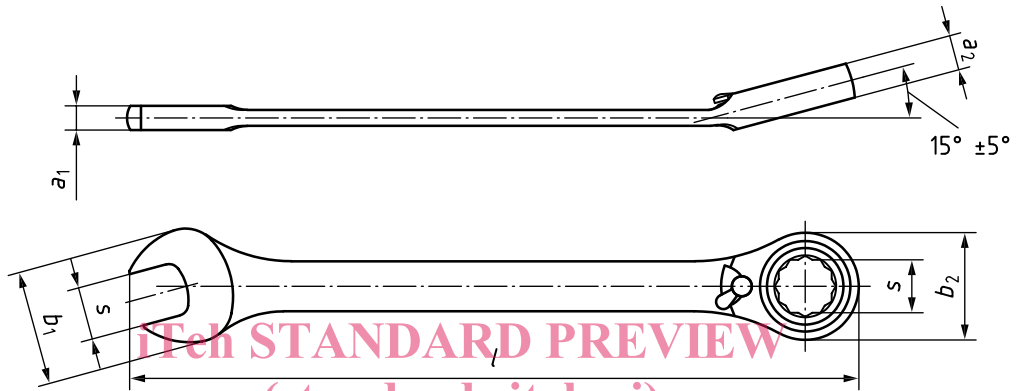

b) Class B

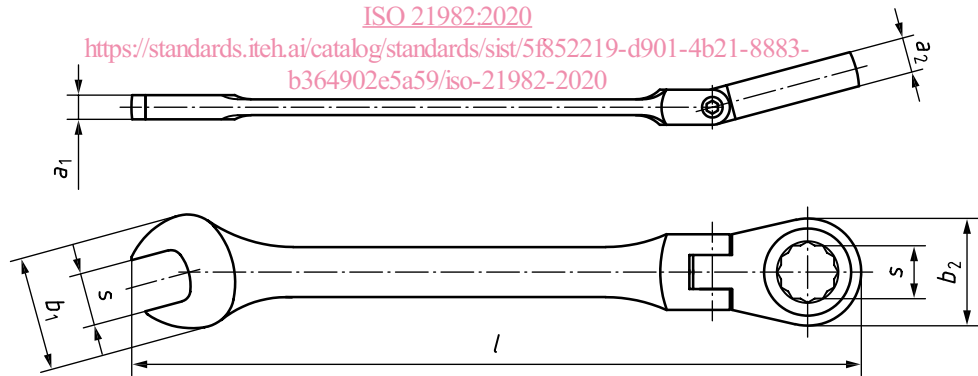

c) Class C

Key

- s nominal width across flats
- a_1, a_2 thickness of head
- b_1, b_2 outside widths of head
- l overall length

Figure 1 — Combination wrenches, ratcheting, Type I

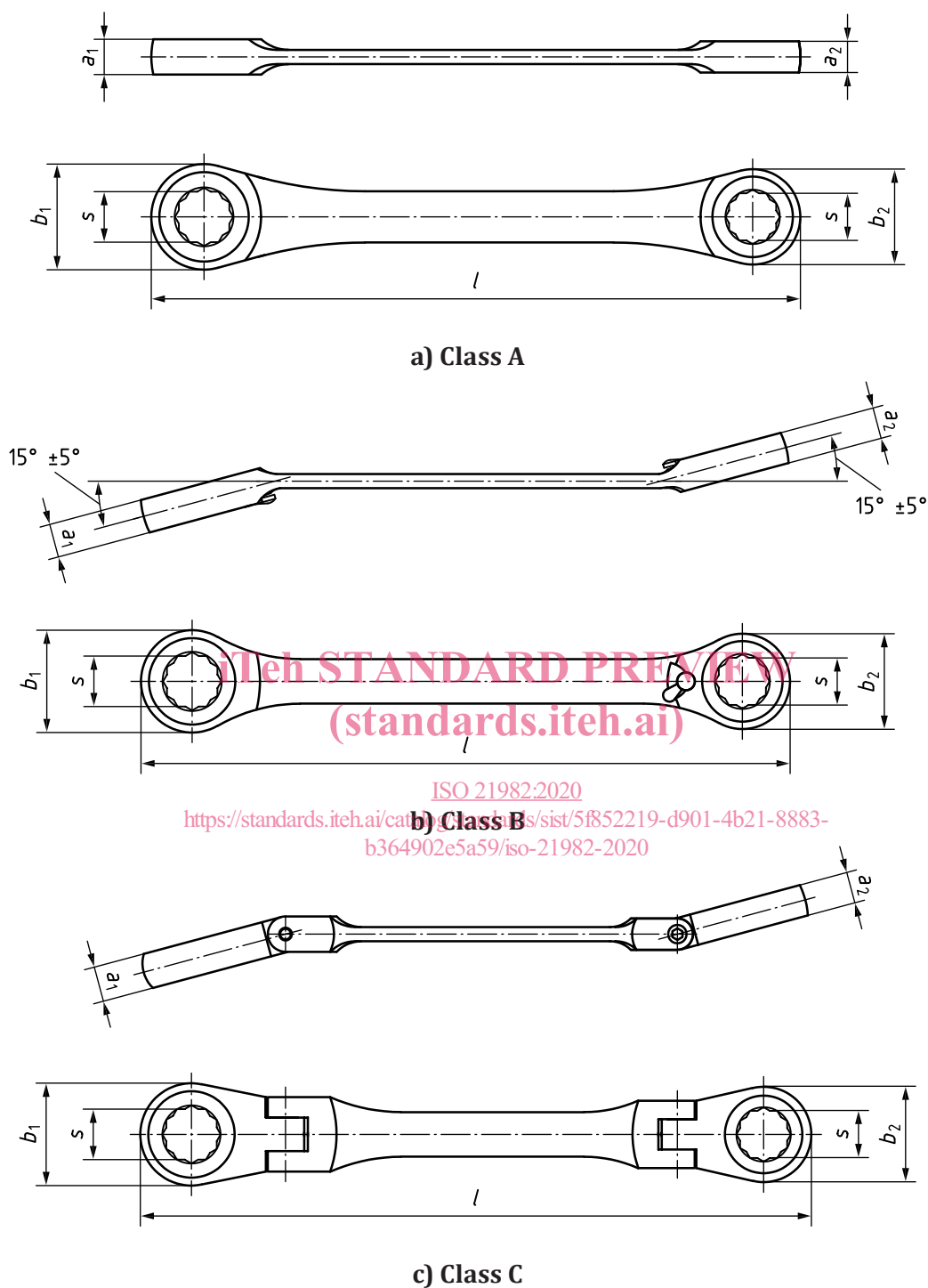

Key

- s nominal width across flats
- a_1, a_2 thickness of head
- b_1, b_2 outside widths of head
- l overall length

Figure 2 — Double-headed box wrenches, ratcheting, Type II

5 Dimension

5.1 Dimensions of combination wrenches, ratcheting

The dimensions of combination wrenches, ratcheting are given in [Table 1](#), see [Figure 1](#).

Table 1 — Dimensions of combination wrenches, ratcheting

Dimensions in millimetres

Nominal width across flat s^a	a_1 maximum	a_2 maximum	b_1 maximum	b_2 maximum	l minimum
6	4,5 ^b	7,5	20 ^c	18,5	80
7	5 ^b	8	22 ^c	19	80
8	5 ^b	8 ^b	24 ^c	19,5	85
9	5,5 ^b	8,5 ^b	25 ^c	21,5	90
10	6 ^b	9 ^b	28 ^c	23	90
11	6,5 ^b	9,5 ^b	30 ^c	24 ^d	100
12	7 ^b	10 ^b	32	26 ^d	100
13	7 ^b	11 ^b	34 ^c	28 ^d	100
14	7,5 ^b	11,5 ^b	36 ^c	30 ^d	110
15	8 ^b	12 ^b	39 ^c	32 ^d	115
16	8 ^b	12,5 ^b	41 ^c	34 ^d	120
17	8,5 ^b	13 ^b	42 ^c	35 ^d	120
18	9 ^b	14 ^b	45 ^c	38 ^d	125
19	9 ^b	14,5 ^b	47 ^c	40,5 ^d	130
20	10 ^b	15 ^b	49 ^c	42,5	130
21	10 ^b	15,5 ^b	51 ^c	43,5 ^d	150
22	10,5 ^b	16 ^b	53 ^c	45,5 ^d	150
23	11 ^b	17 ^b	55 ^c	50	150
24	12	17,5 ^b	57 ^c	51	230
25	12 ^b	18 ^b	59 ^c	51,5 ^d	235
26	12	18	59	54	245
27	13	19 ^b	64 ^c	55,5 ^d	255
28	13,5	19,5	65	59	265
29	13,5	19,5	67	60	275
30	13,5 ^b	20 ^b	70 ^c	61 ^d	285
31	13,5	20	72	65	290
32	14,5 ^b	21 ^b	74 ^c	65 ^d	300
34	15 ^b	22,5 ^b	78 ^c	66	320
36	15,5 ^b	23,5 ^b	83 ^c	70	335
38	16,5	24	88	71	350
41	17,5 ^b	26,5 ^b	93 ^c	74	380

^a The tolerances shall be in accordance with ISO 691.

^b The value shall be according to ISO 7738.

^c The value shall be according to ISO 3318.

^d The value is approximately equal to the value in ISO 3318, multiplied by factor 1,3.