



Designation: F883 – 09

Standard Performance Specification for Padlocks¹

This standard is issued under the fixed designation F883; the number immediately following the designation indicates the year of original adoption or, in the case of revision, the year of last revision. A number in parentheses indicates the year of last reapproval. A superscript epsilon (ϵ) indicates an editorial change since the last revision or reapproval.

This standard has been approved for use by agencies of the Department of Defense.

1. Scope

1.1 This specification covers environmental, functional, operational, and security requirements for padlocks. Included are function descriptions, cycle tests, operational tests, environmental tests, forcing tests, and surreptitious entry tests. No effort has been made to include criteria for specially made padlocks used by the Department of Defense or others in highly sensitive locations.

1.2 This specification describes and grades various levels of performance to provide users of the specification with criteria upon which to select suitable padlocks.

1.3 Tests described are laboratory tests and although they simulate field conditions as to attacks or the environment, they do not duplicate these conditions. Tests described are repeatable in the laboratory.

1.4 Some users of this specification may wish to use padlocks that have special attributes not related to security. These are found in 4.3.

1.5 The values stated in SI units are to be regarded as the standard. The inch-pound units given in parentheses are provided for information only.

1.6 The following precautionary caveat pertains only to the test method portions, Sections 8-11, of this specification: *This standard does not purport to address the safety concerns, if any, associated with its use. It is the responsibility of the user of this standard to establish appropriate safety and health practices and determine the applicability of regulatory limitations prior to use.*

2. Referenced Documents

2.1 ASTM Standards:²

B117 Practice for Operating Salt Spray (Fog) Apparatus

¹ This specification is under the jurisdiction of ASTM Committee F12 on Security Systems and Equipment and is the direct responsibility of Subcommittee F12.50 on Locking Devices.

Current edition approved Nov. 1, 2009. Published December 2009. Originally approved in 1984. Last previous edition approved in 2004 as F883 – 04. DOI: 10.1520/F0883-09.

² For referenced ASTM standards, visit the ASTM website, www.astm.org, or contact ASTM Customer Service at service@astm.org. For *Annual Book of ASTM Standards* volume information, refer to the standard's Document Summary page on the ASTM website.

G154 Practice for Operating Fluorescent Light Apparatus for UV Exposure of Nonmetallic Materials

2.2 ANSI Standard:³

A 156.5 Standard for Auxiliary Locks and Associated Products

3. Terminology

3.1 Definitions of Terms Specific to This Standard:

3.1.1 *acceptance testing*, *v*—to assure by documented testing that a padlock meets specific tests of Specification F883 as agreed to by the buyer and seller.

3.1.2 *bump key*, *n*—lock picking key with uniform steeples between cuts that is forced further into the lock via impact.

3.1.3 *cam*, *n*—lock or cylinder component which transfers the rotational motion of a key or cylinder plug to the bolt works of a lock.

3.1.4 *case*, *n*—housing or body of a lock or latch.

3.1.5 *certified*, *v*—to assure by documented testing that a padlock meets all test requirements appropriate to its grading.

3.1.6 *clevis*, *n*—fastener attached to a padlock case or shackle for connection of a chain, designed to prevent displacement of a padlock.

3.1.7 *cylinder*, *n*—complete operating unit which usually consists of the plug, shell, tumblers, springs, plug retainer, a cam/tailpiece or other actuating device, and all other necessary operating parts.

3.1.8 *cylinder biting*, *n*—group of numbers that represent the biting of a key or the tumblers, or both, of a lock or cylinder.

3.1.9 *decode*, *v*—to determine a key combination by physical measurement of a key or cylinder parts, or both.

3.1.10 *heel*, *n*—part of a padlock shackle that normally is retained in the case when in the unlocked position.

3.1.11 *impression technique*, *v*—means of fitting a key directly to a locked cylinder by manipulating a blank in the keyway and cutting the blank where the tumblers have made marks.

³ Available from American National Standards Institute (ANSI), 25 W. 43rd St., 4th Floor, New York, NY 10036.

3.1.12 *keyway*, *n*—opening in a lock or cylinder that is shaped to accept a key bit or blade of a proper configuration.

3.1.13 *lock bumping*, *n*—picking technique that utilizes a configured key forcefully impacted into the keyway.

3.1.14 *padlock*, *n*—detachable and portable lock with a shackle that locks into its case. Components performing the same purpose of a shackle but differing in design are sometimes used instead of a shackle.

3.1.15 *pick*, *v*—to manipulate tumblers in a keyed lock mechanism through the keyway, without obvious damage, by means other than the specifically designed key.

3.1.16 *plug*, *n*—part of a cylinder which contains the keyway, with tumbler chambers usually corresponding to those in the cylinder shell.

3.1.17 *plug retainer*, *n*—cylinder component that secures the plug in the shell.

3.1.18 *pull bump key*, *n*—lock picking key that must be pulled from the lock one space position between impacts.

3.1.19 *push bump key*, *n*—lock picking key that centers itself after each impact.

3.1.20 *rap*, *v*—to unlock a padlock shackle from its case by striking the case in order to disengage the locking mechanism.

3.1.21 *removable cylinder*, *n*—cylinder that can be removed from a locking device by a key or tool, or both.

3.1.22 *shackle*, *n*—part of a padlock that passes through an opening in an object or fits around an object and is ultimately locked into the case.

3.1.23 *shroud*, *n*—material on a padlock body specifically added to protect the shackle from physical attack.

3.1.24 *tailpiece*, *n*—actuator attached to or part of the rear of the cylinder.

3.1.25 *toe*, *n*—part of a padlock shackle that is normally released from the case in the unlocked position.

3.1.26 *tumbler*, *n*—movable obstruction of varying size and configuration in a lock or cylinder that makes direct contact with the key or another tumbler and prevents an incorrect key or torquing device from activating the lock or other mechanism.

4. Classification of Functions

4.1 Types of Padlocks:

4.1.1 *Type P01*—Key operated.

4.1.2 *Type P02*—Combination operated.

4.2 *Grades*—Six levels of performance are described in this specification with Grade 1 the lowest and Grade 6 the highest.

4.3 Options:

4.3.1 *Option A*—Key is captive in cylinder when padlock is unlocked.

4.3.2 *Option B*—Removable cylinder.

4.3.3 *Option C*—Changeable combination.

4.3.4 *Option D*—Combination operated with key control.

4.3.5 *Option E*—Corrosion resistant.

4.3.6 *Option F*—Provided with nonferrous shackles.

4.3.7 *Option G*—Environmental resistant.

5. General Requirements

5.1 *Inferences*—Cylinder picking, impressioning, rapping, decoding, and shackle shimming are described in this specification. Since the skill of the person doing the testing has a direct bearing on the resulting times of the tests, one of each test shall be conducted by a minimum of three different persons having experience of not less than three years of approximately the same skill level and the results averaged for determining relative levels of performance.

5.2 Key bumping is a subjective test to be conducted using bump keys designed for the lock or cylinder being tested and an impact device as outlined in Section 7.

5.3 Tolerances:

5.3.1 *Fixture Tolerances*—All tolerances shall follow standard machining practices unless otherwise specified.

5.3.2 Test Set up Tolerances:

5.3.2.1 *Force*: 0.5 % of working range.

5.3.2.2 *Height*: ± 3 mm (0.12 in.).

5.3.2.3 *Torque*: 4.0 % of reading.

5.3.2.4 *Weight*: ± 10 g (0.02 lbs).

5.4 *Temperature*—All tests shall be conducted between 16° and 27°C (61° and 81°F).

5.5 *Test Reports*—All test reports shall be dated.

6. Test Specimens

6.1 Select specimens for test at random from the manufacturers' finished stock of each size and model being certified by the manufacturer.

6.2 Padlocks or cylinders are permitted to be used for multiple tests if previous tests would not influence subsequent test results.

6.3 Select four padlocks or cylinders for the forcing tests. For surreptitious entry tests, select five padlocks or cylinders for each test required. Select one padlock or cylinder for the cycle test.

6.4 Each lock submitted for bump testing shall be supplied with seven cut keys that operate the lock.

6.5 When appropriate, select one padlock for the salt spray test (Option E) and three for the environmental tests (Option G).

7. Preparation of Apparatus

7.1 *Tensile Loading Device*—Provide a tensile loading device having a load and force measuring capacity of 44 500 N (10 000 lbf).

7.2 Shock Impactor:

7.2.1 Provide a fixture as illustrated in Fig. 1 which allows the weights described in (7.2.2) to be properly guided to strike the anvil rod which will be placed in direct contact with the top surface of a padlock using the mounting block described in (7.2.3).

7.2.2 Make a set of weights as shown in Fig. 1, with a central hole in each that allows the weight selected to free fall and strike the top surface of the anvil rod.

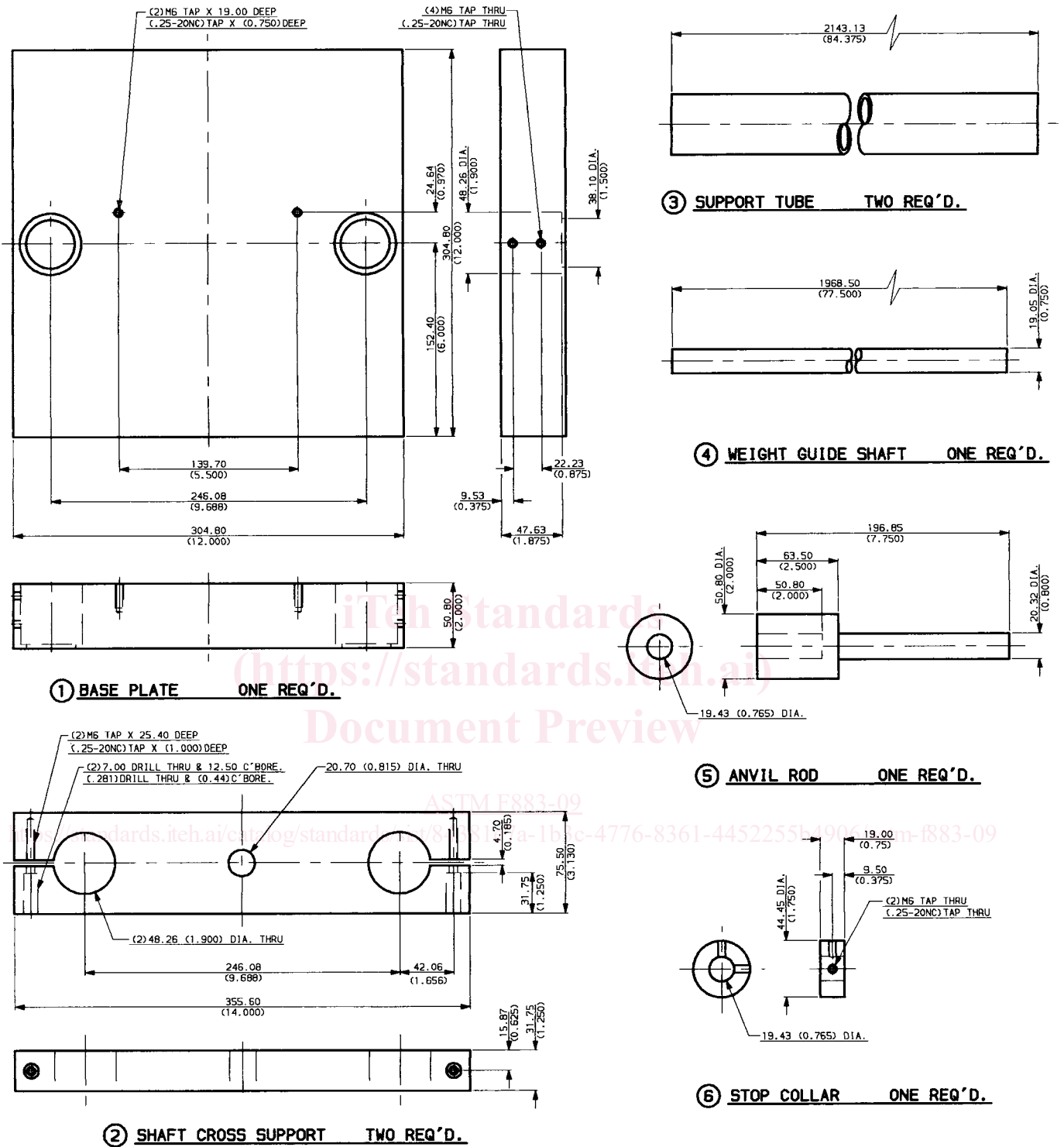

FIG. 1 (Sheet 1) Shock Impactor (See Table 5 for Bill of Material)

7.2.3 Make a mounting block that will support the specimen on the mounting block when being subjected to the required shock load (see Table 1).

7.3 Key Bumping:

7.3.1 Each locksmith performing the test shall use two of the supplied keys to fabricate his own pull bump key and push bump key.

7.3.2 Both a pull bump key and a push bump key shall be used to test a lock or cylinder for bump resistance by each of three locksmiths.

7.3.2.1 A torque bar is permitted to be used if the test person prefers that method.

7.3.2.2 A single impact cycle consists of having a bump key fully inserted into the keyway and withdrawing it one cut

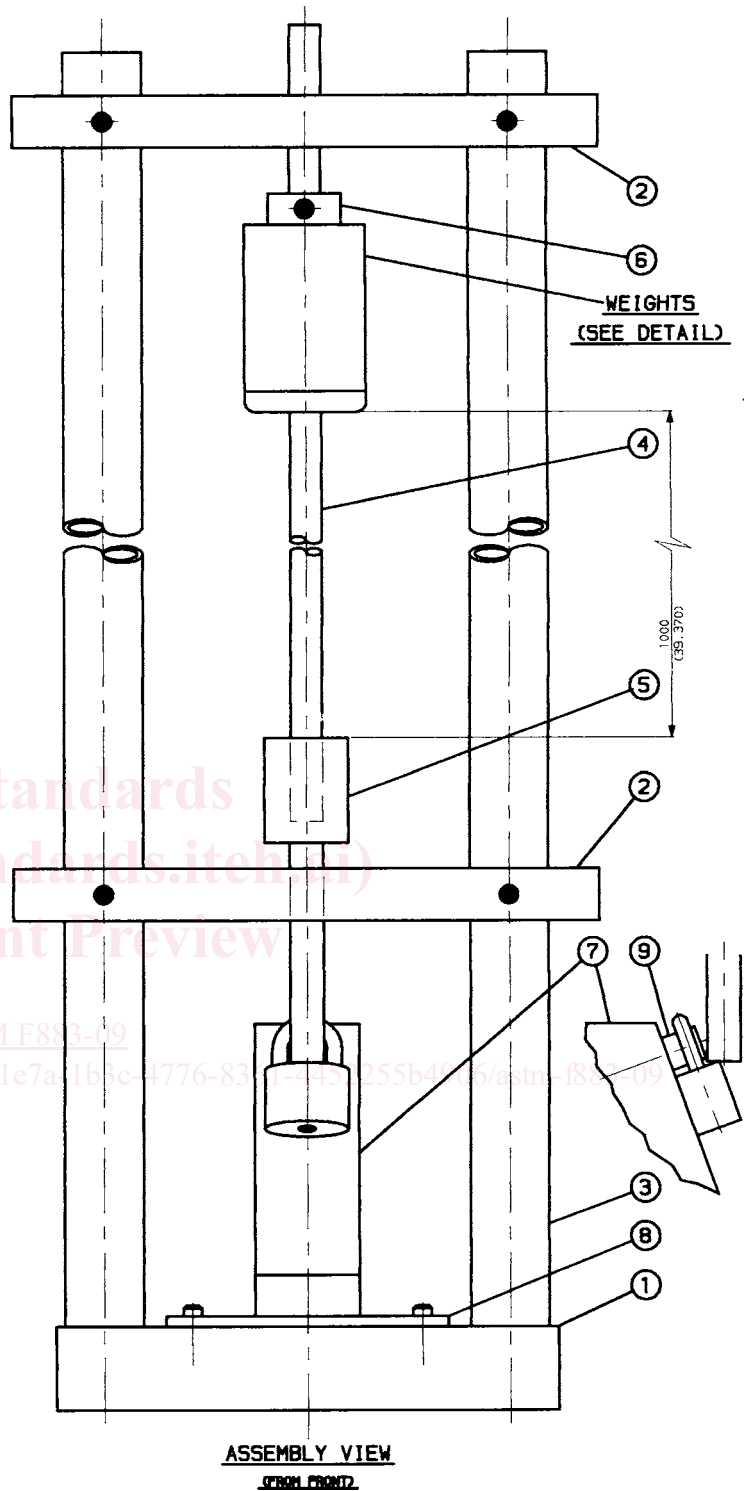
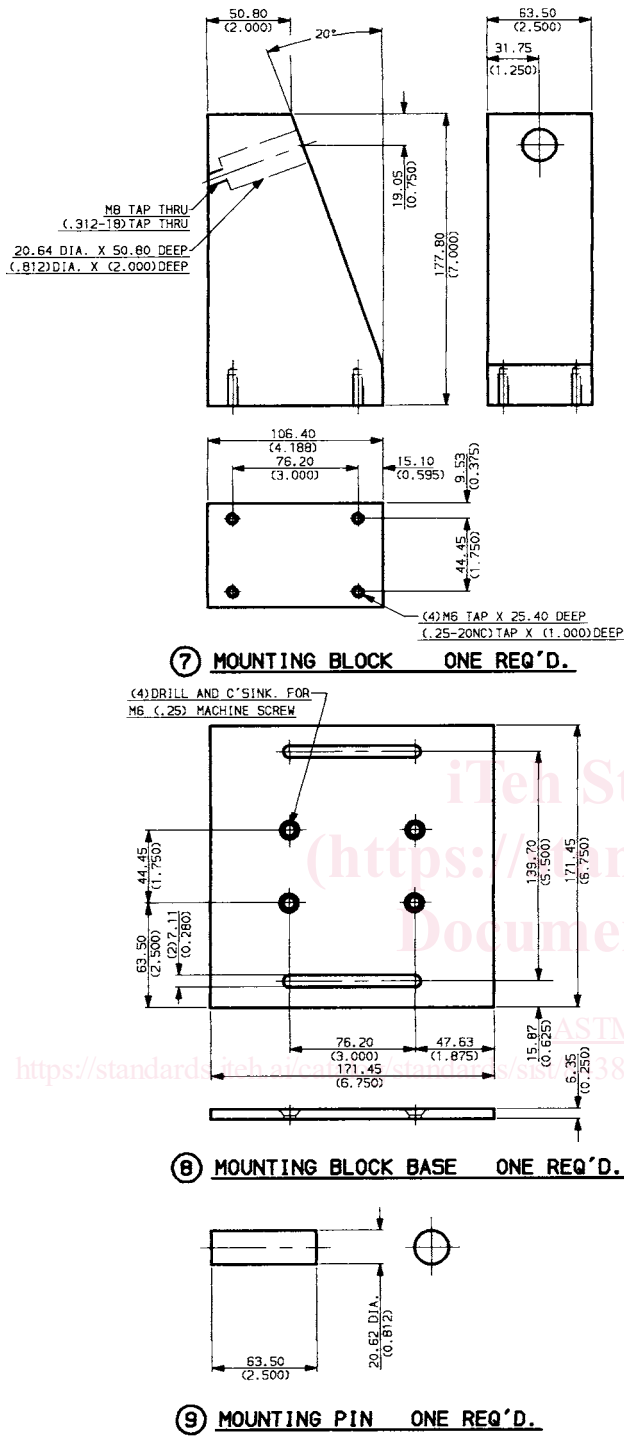
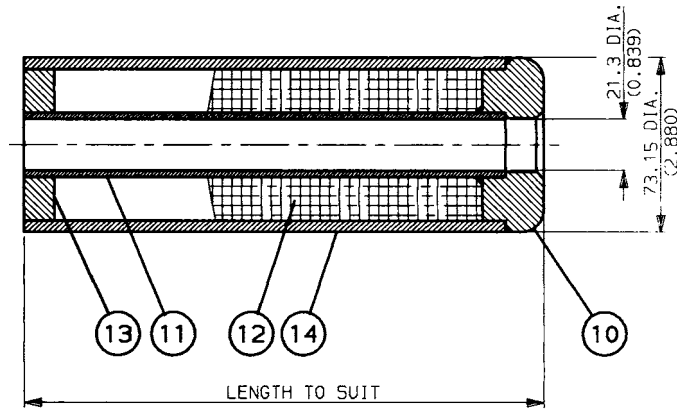

FIG. 2 (Sheet 2) Shock Impactor (See Table 5 for Bill of Material)

position for the pull type, inserting the key fully into the keyway and then releasing it to allow the pins to center it for the push type, impacting the end of the key to drive it fully into the keyway while torque is applied. If the cylinder or lock operates after the impact, it failed the test at that cycle and shall be given the appropriate grade level for the last cycle that did

not accomplish operation. If it did not operate, a new cycle shall be achieved until the lock or cylinder reaches Grade 6.

7.3.3 Provide various mounting blocks for locks or cylinders as required by the test person if rigid mounting is preferred.



DEAD BLOW WEIGHT SIX REQ'D.

FIG. 3 (Sheet 3) Shock Impactor (See Table 5 for Bill of Material)

TABLE 1 Forcing Tests Required Values

Forcing Tests	Units	Grades					
		1 (F1)	2 (F2)	3 (F3)	4 (F4)	5 (F5)	6 (F6)
Tensile Force	newtons (lbf)	1000 (225)	2500 (560)	5000 (1125)	9000 (2000)	20 000 (4500)	40 000 (9000)
Shock test blows		5	5	5	5	5	5
Shock test weights	kilograms (lbs)	1 (2.2)	2 (4.4)	3 (6.6)	4 (8.8)	5 (11.0)	6 (13.2)
Shock test heights	meters (in.)	1 (39.4)	1 (39.4)	1 (39.4)	1 (39.4)	1 (39.4)	1 (39.4)
Plug pull test	newtons (lbf)	1000 (225)	1500 (337)	2000 (450)	3000 (675)	6000 (1350)	12 000 (2700)
Plug torque test	newton-meters (lbf-in.)	10 (89)	15 (133)	20 (177)	25 (221)	30 (266)	35 (310)
Shackle cutting force test	newtons (lbf)	4450 (1000)	9000 (2000)	13 500 (3000)	18 000 (4000)	31 000 (7000)	45 000 (10 000)

7.3.4 The impact device shall be a non-metal instrument with a weight not to exceed 0.25 lb.

TEST METHODS

8. Forcing Tests (see Table 1)

8.1 *Tensile Test* (Does not apply if test cannot be performed) (see 7.1)—Support the locked padlock in a fixture bearing against the top surface of the case without interfering with the shackle or giving support through the top of the case to the shackle retaining mechanism. Apply the required force slowly along the vertical centerline of the padlock in a direct and equal tension on each leg of the shackle. Failure occurs if the padlock opens.

8.2 *Shock Test*—Using the impactor (7.2) drop the weight the required number of times on the top of the locked padlock case. Failure occurs if the padlock opens.

8.3 *Plug Pulling Test*—Drill the keyway with a No. 20 (0.161 in.) diameter drill and insert a Type AB No. 12 screw at least 19 mm (0.75 in.) deep. Apply the required tension (7.1) axially between the case and the installed screw. Failure occurs if the cylinder plug or cylinder assembly completely separates from the case, or if the padlock can be opened by manipulation with a screwdriver at the conclusion of the test.

NOTE 1—Some cylinders are of a configuration such that a different attachment may be needed in order to apply the required loads.

8.4 Plug Torque Test:

8.4.1 Install the padlock in a rigid fixture such as a vise to support it firmly but not restrict free rotation of the plug in the cylinder.

8.4.2 Insert a blade type tool into the keyway, so that a torque load can be applied to the plug. Failure occurs if the padlock opens.

8.5 *Shackle Cutting Test* (Does not apply if test cannot be performed)—Shackles shall withstand cutting through when 2 shearing blades made of a steel hardened to a minimum hardness of Rc 50, are used in conjunction with the blade positioning holder, is placed in a tensile loading device (7.1) having a compression load capability and compressed with the required force. See Fig. 4 for details. Failure occurs if the shackle is cut through. Padlocks specified with Option F are not subject to 8.6.

9. Surreptitious Entry Tests (see Table 2)

9.1 Picking or Manipulating Test:

9.1.1 Cylinders in padlocks shall resist picking (see 5.1) for the required time. Combination padlocks shall resist manual manipulation (see 5.1) for the required time.

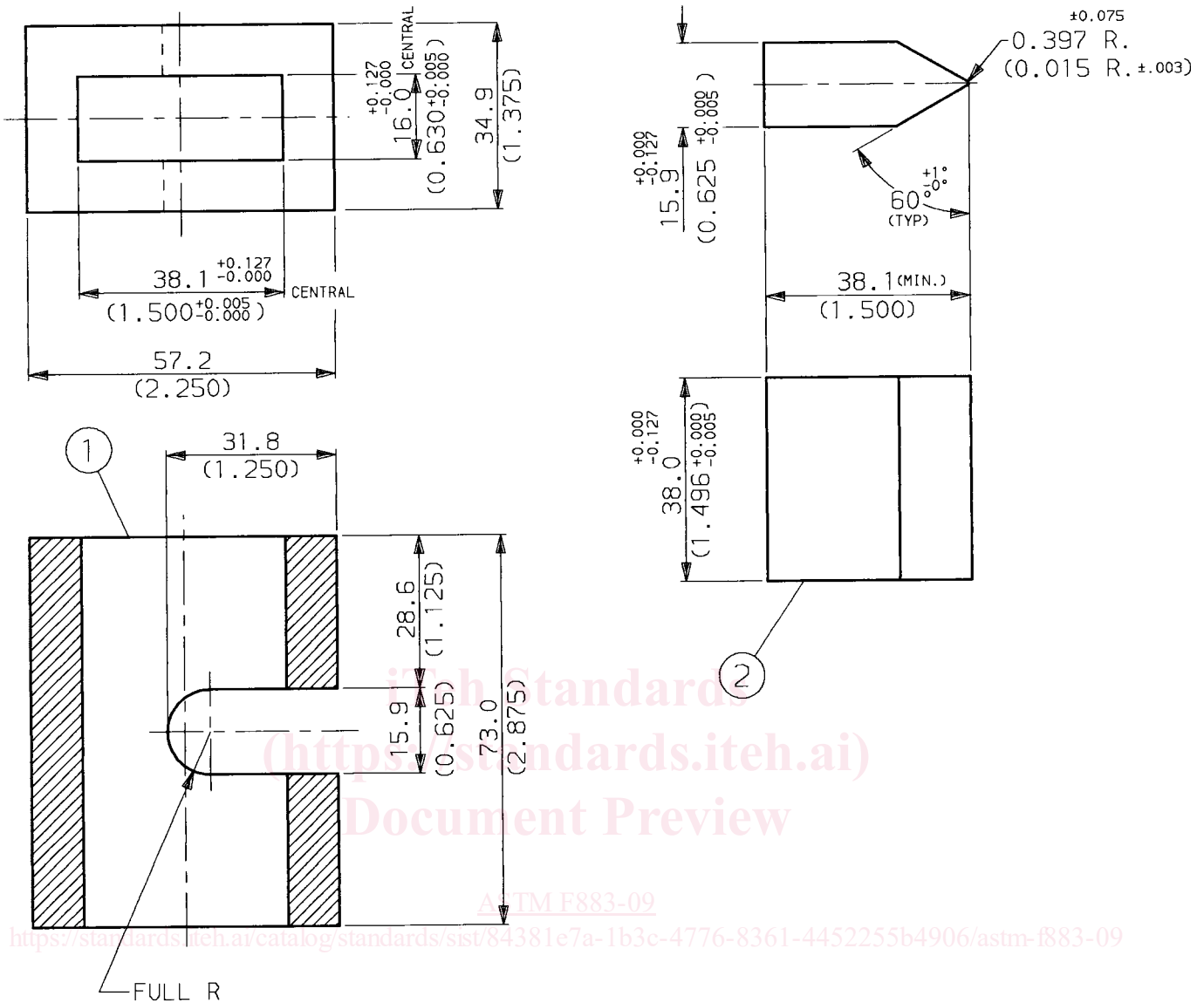

NOTE 1—Item No. 1 may be made as a multi-piece part that could be assembled by either bolt or weld construction.
FIG. 4 (Sheet 1) Shackle Cutting Fixture and Blades (See Table 6 for Bill of Material)

TABLE 2 Surreptitious Entry Tests Required Values

Surreptitious Entry Tests	Grades					
	1 (S1)	2 (S2)	3 (S3)	4 (S4)	5 (S5)	6 (S6)
Picking or Manipulation, min	½	1	2	4	8	15
Bump Key Attack, min	2 ½	5	7 ½	10	12 ½	15
Impressioning or Decoding min	N/A	N/A	2	4	8	15
Shackle Shimming Test min	½	1	2	4	8	15
Drilling and Shimming min	N/A	N/A	N/A	4	8	15
Rapping min	N/A	N/A	2	4	8	15

9.1.2 Cylinders or padlocks submitted for test containing pin tumblers shall be loaded using one each of the three or four mid-range bittings available unless such a combination would not normally be supplied as a stock product. Cylinders in padlocks containing other tumbler elements shall be loaded using maximum ranges. If lock design and cylinders used are

the same in several different sizes of padlocks submitted for testing, only a total of five samples of any size or sizes need to be tested.

9.1.3 The tools used for this test shall be manual manipulating tools required by the operator, providing no visible marks are left detectable by the unaided eye.