

INTERNATIONAL STANDARD

ISO 2380-1

First edition
1989-05-01

Screwdrivers for slotted-head screws —

Part 1 :

Tips for hand- and machine-operated screwdrivers

iTeh STANDARD PREVIEW

Tournevis pour vis à tête fendue —

(standards.iteh.ai)
Partie 1 : Extrémités de tournevis à main et à machine

ISO 2380-1:1989

<https://standards.iteh.ai/catalog/standards/sist/b7bbb20d-fe98-44df-9464-e865706d5e89/iso-2380-1-1989>



Reference number
ISO 2380-1 : 1989 (E)

Foreword

ISO (the International Organization for Standardization) is a worldwide federation of national standards bodies (ISO member bodies). The work of preparing International Standards is normally carried out through ISO technical committees. Each member body interested in a subject for which a technical committee has been established has the right to be represented on that committee. International organizations, governmental and non-governmental, in liaison with ISO, also take part in the work. ISO collaborates closely with the International Electrotechnical Commission (IEC) on all matters of electrotechnical standardization.

Draft International Standards adopted by the technical committees are circulated to the member bodies for approval before their acceptance as International Standards by the ISO Council. They are approved in accordance with ISO procedures requiring at least 75 % approval by the member bodies voting.

International Standard ISO 2380-1 was prepared by Technical Committee ISO/TC 29, *Small tools*.

[ISO 2380-1:1989](https://standards.iteh.ai/catalog/standards/sist/b7bbb20d-fe98-44df-9464-1989)

<https://standards.iteh.ai/catalog/standards/sist/b7bbb20d-fe98-44df-9464-1989>

This first edition of ISO 2380-1 cancels and replaces ISO 2380:1979, of which it constitutes a technical revision.

ISO 2380 will consist of the following parts, under the general title *Screwdrivers for slotted-head screws*:

- *Part 1: Tips for hand- and machine-operated screwdrivers*
- *Part 2: Lengths*

Screwdrivers for slotted-head screws —

Part 1 :

Tips for hand- and machine-operated screwdrivers

iTeh STANDARD PREVIEW
(standards.iteh.ai)

1 Scope

This part of ISO 2380 specifies the designation, shape and dimensions of the tips of hand- and machine-operated screwdrivers for slotted-head screws. It also gives the technical specifications and test conditions for the screwdrivers and, in the case of hand-operated screwdrivers, specifies the test torque which the blade-to-handle connection shall withstand.

c) the nominal thickness, *a*, in millimetres;

d) the nominal width, *b*, in millimetres.

EXAMPLE

The designation for a tip, type A, of nominal thickness 1,2 mm and of nominal width 8 mm is as follows :

Tip type A-1,2 × 8

2 Designation of the tips

The designation of the tips shall include, in the following order :

- a) "Tip";
- b) the type;

3 Shape and dimensions of the tips

3.1 Shape

The shape of screwdriver tips is left to the choice of the manufacturer.

3.2 Dimensions

Only the dimensions specified in tables 1 and 2 shall be observed.

Type A (for hand-operated screwdrivers)

Type B (for hand-operated screwdrivers)
Type C (for machine-operated screwdrivers)

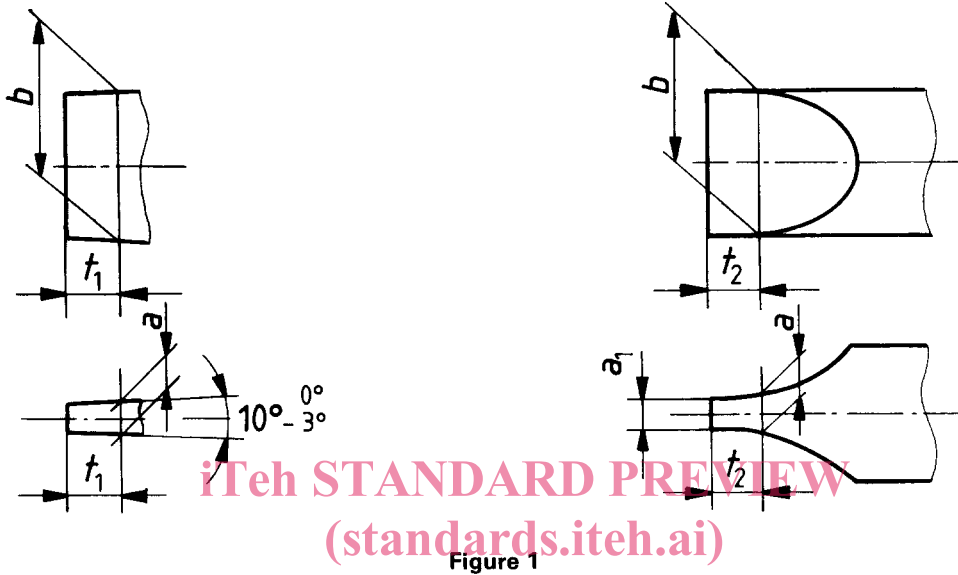

ISO 2380-1:1989

<https://standards.iteh.ai/catalog/standards/sist/b7bbb20d-fe98-44df-9464-e865706d5e89/iso-2380-1-1989>

Table 1 — Hand-operated screwdriver tips

Dimensions and tolerances in millimetres

Nominal thickness <i>a</i>	Types A and B						
	Nominal width <i>b</i>	Tolerances on		<i>t</i> ₁	<i>a</i> ₁ ^{*)} min.	<i>t</i> ₂	Test torque <i>M</i> _{min} daN · m
		<i>a</i>	<i>b</i>				
0,4	2	+0,06 -0,02	h13	0,2	0,3	0,7	0,03
	2,5						0,04
0,5	3			0,3	0,4	0,9	0,07
0,6	3,5			0,4	0,5	1,1	0,13
0,8	4	+0,06 -0,04		0,5	0,6	1,4	0,26
1	5,5			0,6	0,8	1,8	0,55
1,2	6,5	± 0,06		0,7	1	2,2	0,94
	8						1,15
1,6	8			1	1,3	2,9	2,05
	10						2,56
2	12		1,2	1,6	3,6	4,8	
2,5	14		1,5	2	4,5	8,75	

*) *a*₁ < *a*

Table 2 — Machine-operated screwdriver tips

Dimensions and tolerances in millimetres

Nominal thickness <i>a</i>	Type C							
	Nominal width <i>b</i>	Tolerances on		<i>a</i> ₁ ^{*)} min.	<i>t</i> ₂	Test torque <i>M</i> _{1, min} daN·m		
		<i>a</i>	<i>b</i>					
0,4	2	k10 (+ 0,04 0)	h11	0,3	0,7	0,035		
	2,5					0,045		
0,5	3			0,4	0,9	0,08		
	4					0,11		
0,6	3,5			0,5	1,1	0,14		
	4,5					0,18		
0,8	4			0,6	1,4	0,29		
	5,5					0,39		
1	5,5			0,8	1,8	0,62		
1,2	6,5			js11 (± 0,03)	h12	1	2,2	1,05
	8							1,29
1,6	8					1,3	2,9	2,29
	10	2,87						
2	12	1,6	3,6			5,38		
2,5	14	2	4,5			9,8		

*) $a_1 < a$

iTeh STANDARD PREVIEW
(standards.iteh.ai)

ISO 2380-1:1989

<https://standards.iteh.ai/catalog/standards/sist/b7bbb20d-fe98-44df-9464-e865706d5e89/iso-2380-1-1989>

4 Technical specifications and test conditions for the screwdrivers

4.1 Hardness

The screwdriver blades or bits shall be heat-treated along their full length. Hand-operated screwdrivers shall have a minimum hardness of 50 HRC over at least the length $3 \times b$ from the tip of the blade and machine-operated screwdrivers shall have a minimum hardness of 56 HRC at the tips.

4.2 Test conditions for the blades or bits

When tested with the minimum test torques M and M_1 , expressed in decanewton metres, specified in tables 1 and 2, the screwdriver blades or bits shall not show any cracks or breaks or any permanent deformations which could influence their usability.

NOTE — The minimum test torques have been calculated using the following formulae :

$$M = 0,1 ba^2, \text{ and}$$

$$M_1 = 0,112 ba^2$$

where

a is the nominal thickness of the tip, expressed in millimetres;

b is the nominal width of the tip, expressed in millimetres.

Special equipment shall be used for the torque test. The test torque on the blade or bit shall be progressively and steadily applied and increased to the indicated test torque M or M_1 , or until the blade or bit breaks. The screwdriver point shall sit fully in the test disc. Bending moments shall not arise during testing.

The test discs (see figure 2) shall have a hardness of at least 64 HRC and be of such strength that no deformation of them can occur during testing.

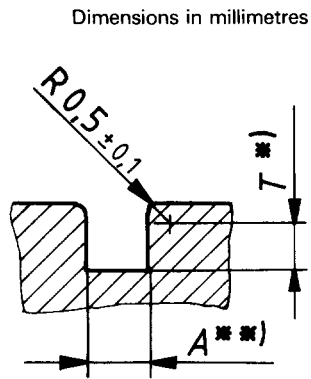

*) For type A :

$$T = t_1 H10$$

For types B and C :

$$T = t_2 H13$$

***) $A = a C9$

Figure 2

4.3 Test torque of the blade-to-handle connection (hand-operated screwdrivers)

The test torque which the blade-to-handle connection shall withstand is related to the test torque of the blade as shown in table 3.

Table 3 – Test torque

Test torque of the blade M daN·m	Test torque of the blade-to-handle connection M' daN·m
$M < 2,6$	$M' > M$
$M > 2,6$	$M' > 3^*)$

*) Where the screwdriver handle has a hole for use with a tee bar, the test torque for the blade-to-handle connection shall be greater than the torque the blade is required to withstand.

NOTE — The application of the test equipment to the handle should not modify the characteristics of the connection to be tested.

iTeh STANDARD PREVIEW
(standards.iteh.ai)

[ISO 2380-1:1989](https://standards.iteh.ai/catalog/standards/sist/b7bbb20d-fe98-44df-9464-e865706d5e89/iso-2380-1-1989)

<https://standards.iteh.ai/catalog/standards/sist/b7bbb20d-fe98-44df-9464-e865706d5e89/iso-2380-1-1989>

iTeh STANDARD PREVIEW
(standards.iteh.ai)

ISO 2380-1:1989

<https://standards.iteh.ai/catalog/standards/sist/b7bbb20d-fe98-44df-9464-e865706d5e89/iso-2380-1-1989>

iTeh STANDARD PREVIEW
(standards.iteh.ai)

ISO 2380-1:1989

<https://standards.iteh.ai/catalog/standards/sist/b7bbb20d-fe98-44df-9464-e865706d5e89/iso-2380-1-1989>

UDC 621.883.7

Descriptors : tools, hand tools, power-operated tools, screwdrivers, screwdriver blades, slotted head screws, dimensions, designation.

Price based on 4 pages
