



Standard Test Methods for Fire Tests of Building Construction and Materials¹

This standard is issued under the fixed designation E119; the number immediately following the designation indicates the year of original adoption or, in the case of revision, the year of last revision. A number in parentheses indicates the year of last reapproval. A superscript epsilon (ϵ) indicates an editorial change since the last revision or reapproval.

This standard has been approved for use by agencies of the Department of Defense.

INTRODUCTION

The performance of walls, columns, floors, and other building members under fire-exposure conditions is an item of major importance in securing constructions that are safe, and that are not a menace to neighboring structures or to the public. Recognition of this is registered in the codes of many authorities, municipal and other. It is important to secure balance of the many units in a single building, and of buildings of like character and use in a community; and also to promote uniformity in requirements of various authorities throughout the country. To do this it is necessary that the fire-resistive properties of materials and assemblies be measured and specified according to a common standard expressed in terms that are applicable alike to a wide variety of materials, situations, and conditions of exposure.

Such a standard is found in the test methods that follow. They prescribe a standard exposing fire of controlled extent and severity. Performance is defined as the period of resistance to standard exposure elapsing before the first critical point in behavior is observed. Results are reported in units in which field exposures can be judged and expressed.

The test methods may be cited as the “Standard Fire Tests,” and the performance or exposure shall be expressed as “2-h,” “6-h,” “1/2-h,” etc.

When a factor of safety exceeding that inherent in the test conditions is desired, a proportional increase should be made in the specified time-classification period.

1. Scope

1.1 The test methods described in this fire-test-response standard are applicable to assemblies of masonry units and to composite assemblies of structural materials for buildings, including loadbearing and other walls and partitions, columns, girders, beams, slabs, and composite slab and beam assemblies for floors and roofs. They are also applicable to other assemblies and structural units that constitute permanent integral parts of a finished building.

1.2 It is the intent that classifications shall register comparative performance to specific fire-test conditions during the

period of exposure and shall not be construed as having determined suitability under other conditions or for use after fire exposure.

1.3 *This standard is used to measure and describe the response of materials, products, or assemblies to heat and flame under controlled conditions, but does not by itself incorporate all factors required for fire hazard or fire risk assessment of the materials, products or assemblies under actual fire conditions.*

1.4 These test methods prescribe a standard fire exposure for comparing the test results of building construction assemblies. The results of these tests are one factor in assessing predicted fire performance of building construction and assemblies. Application of these test results to predict the performance of actual building construction requires the evaluation of test conditions.

1.5 The values stated in inch-pound units are to be regarded as the standard. The values given in parentheses are for information only.

1.6 *This standard does not purport to address all of the safety concerns, if any, associated with its use. It is the*

¹ These test methods are under the jurisdiction of ASTM Committee E05 on Fire Standards and are the direct responsibility of Subcommittee E05.11 on Fire Resistance.

Current edition approved July 15, 2009. Published December 2009. Originally approved in 1917. Last previous edition approved in 2009 as E119 – 09a.

These test methods, of which the present standard represents a revision, were prepared by Sectional Committee on Fire Tests of Materials and Construction, under the joint sponsorship of the National Bureau of Standards, the ANSI Fire Protection Group, and ASTM, functioning under the procedure of the American National Standards Institute. DOI: 10.1520/E0119-09B.

responsibility of the user of this standard to establish appropriate safety and health practices and determine the applicability of regulatory limitations prior to use.

1.7 The text of this standard references notes and footnotes which provide explanatory material. These notes and footnotes (excluding those in tables and figures) shall not be considered as requirements of the standard.

2. Referenced Documents

2.1 *ASTM Standards*:²

C569 Test Method for Indentation Hardness of Preformed Thermal Insulations³

D6513 Practice for Calculating the Superimposed Load on Wood-frame Walls for Standard Fire-Resistance Tests

E176 Terminology of Fire Standards

E814 Test Method for Fire Tests of Penetration Firestop Systems

E2226 Practice for Application of Hose Stream

3. Terminology

3.1 *Definitions*—For definitions of terms found in this test method, refer to Terminology **E176**.

4. Significance and Use

4.1 These test methods are intended to evaluate the duration for which the types of building elements noted in **1.1** contain a fire, retain their structural integrity, or exhibit both properties during a predetermined test exposure.

4.2 The test exposes a test specimen to a standard fire controlled to achieve specified temperatures throughout a specified time period. When required, the fire exposure is followed by the application of a specified standard fire hose stream applied in accordance with Practice **E2226**. The test provides a relative measure of the fire-test-response of comparable building elements under these fire exposure conditions. The exposure is not representative of all fire conditions because conditions vary with changes in the amount, nature and distribution of fire loading, ventilation, compartment size and configuration, and heat sink characteristics of the compartment. Variation from the test conditions or test specimen construction, such as size, materials, method of assembly, also affects the fire-test-response. For these reasons, evaluation of the variation is required for application to construction in the field.

4.3 The test standard provides for the following:

4.3.1 For walls, partitions, and floor or roof test specimens:

4.3.1.1 Measurement of the transmission of heat.

4.3.1.2 Measurement of the transmission of hot gases through the test specimen.

4.3.1.3 For loadbearing elements, measurement of the load carrying ability of the test specimen during the test exposure.

4.3.2 For individual loadbearing members such as beams and columns:

4.3.2.1 Measurement of the load carrying ability under the test exposure with consideration for the end support conditions (that is, restrained or not restrained).

4.4 The test standard does not provide the following:

4.4.1 Information as to performance of test specimens constructed with components or lengths other than those tested.

4.4.2 Evaluation of the degree by which the test specimen contributes to the fire hazard by generation of smoke, toxic gases, or other products of combustion.

4.4.3 Measurement of the degree of control or limitation of the passage of smoke or products of combustion through the test specimen.

4.4.4 Simulation of the fire behavior of joints between building elements such as floor-wall or wall-wall, etc., connections.

4.4.5 Measurement of flame spread over the surface of test specimens.

4.4.6 The effect on fire-resistance of conventional openings in the test specimen, that is, electrical receptacle outlets, plumbing pipe, etc., unless specifically provided for in the construction tested. Also see Test Method **E814** for testing of fire stops.

5. Test Specimen

5.1 The test specimen shall be representative of the construction that the test is intended to assess, as to materials, workmanship, and details such as dimensions of parts, and shall be built under conditions representative of those applied in building construction and operation. The physical properties of the materials and ingredients used in the test specimen shall be determined and recorded.

5.2 The size and dimensions of the test specimen specified herein shall apply for classifying constructions of dimensions within the range employed in buildings. When the conditions of use limit the construction to smaller dimensions, the dimensions of the test specimen shall be reduced proportionately for a test qualifying them for such restricted use.

5.3 Test specimens designed with a built-up roof shall be tested with a roof covering of 3-ply, 15-lb (6.8-kg) type felt, with not more than 120 lb (54 kg) per square (100 ft² (9 m²)) of hot mopping asphalt without gravel surfacing. Tests with this covering do not preclude the field use of other coverings with a larger number of plies of felt, with a greater amount of asphalt or with gravel surfacing.

5.4 Roofing systems designed for other than the use of built-up roof coverings shall be tested using materials and details of construction representative of field application.

6. Protection and Conditioning of Test Specimen

6.1 Protect the test specimen during and after fabrication to ensure its quality and condition at the time of test. The test specimen shall not be tested until its required strength has been attained, and, until an air-dry condition has been achieved in accordance with the requirements given in **6.2-6.4**. Protect the testing equipment and test specimen undergoing the fire-resistance test from any condition of wind or weather that is capable of affecting results. The ambient air temperature at the beginning of the test shall be within the range of 50 to 90°F (10 to 32°C). The velocity of air across the unexposed surface of

² For referenced ASTM standards, visit the ASTM website, www.astm.org, or contact ASTM Customer Service at service@astm.org. For *Annual Book of ASTM Standards* volume information, refer to the standard's Document Summary page on the ASTM website.

³ Withdrawn.

the test specimen, measured just before the test begins, shall not exceed 4.4 ft (1.3 m/s), as determined by an anemometer placed at right angles to the unexposed surface. When mechanical ventilation is employed during the test, an air stream shall not be directed across the surface of the test specimen.

6.2 Prior to the fire-resistance test, condition test specimens with the objective of providing moisture condition within the test specimen representative of that in similar construction in buildings. For purposes of standardization, this condition is established at equilibrium resulting from conditioning in an ambient atmosphere of 50 % relative humidity at 73°F (Note 1).

6.2.1 With some constructions it is difficult or impossible to achieve such uniformity. Where this is the case, test specimens are tested when the dampest portion of the test specimen, or the portion at 6-in. (152-mm) depth below the surface of massive constructions, has achieved a moisture content corresponding to conditioning to equilibrium with air in the range of 50 to 75 % relative humidity at 73 ± 5°F (23 ± 3°C).

6.2.2 When evidence is shown that test specimens conditioned in a heated building will fail to meet the requirements of 6.2 after a 12-month conditioning period, or in the event that the nature of the construction is such that it is evident that conditioning of the test specimen interior is prevented by hermetic sealing, the moisture condition requirements of 6.2 are permitted to be waived, and either 6.2.2.1 or 6.2.2.2 shall apply.

6.2.2.1 Alternative conditioning methods are permitted to be used to achieve test specimen equilibrium prescribed in 6.2 (Note 2), or

6.2.2.2 The specimen tested when its strength is at least equal to its design strength after a minimum 28 day conditioning period.

6.3 Avoid conditioning procedures that will alter the structural or fire-resistance characteristics of the test specimen from those produced as the result of conditioning in accordance with procedures given in 6.2.

6.4 Information on the actual moisture content and distribution within the test specimen shall be obtained within 72 h prior to the fire. Include this information in the test report (Note 3).

NOTE 1—A recommended method for determining the relative humidity within a hardened concrete test specimen with electric sensing elements is described in Appendix I of the paper by Menzel, C. A., "A Method for Determining the Moisture Condition of Hardened Concrete in Terms of Relative Humidity," *Proceedings*, ASTM, Vol 55, 1955, p. 1085. A similar procedure with electric sensing elements is permitted to be used to determine the relative humidity within test specimens made with other materials.

With wood constructions, the moisture meter based on the electrical resistance method can be used, when appropriate, as an alternative to the relative humidity method to indicate when wood has attained the proper moisture content. Electrical methods are described on page 12-2 of the 1999 edition of the *Wood Handbook of the Forest Products Laboratory*, U.S. Department of Agriculture. The relationships between relative humidity and moisture content are given in Table 3-4 on p. 3-7. This indicates that wood has a moisture content of 13 % at a relative humidity of 70 % for a temperature of 70 to 80°F (21 to 27°C).

NOTE 2—An example where alternative conditioning may be employed is where concrete specimens are conditioned at elevated temperatures in a

"heated building" to more rapidly obtain the conditions described in 6.2. In such cases, temperatures other than 73°F are used to reach a maximum 50 % relative humidity.

NOTE 3—If the moisture condition of the test specimen is likely to change drastically from the 72-h sampling time prior to test, the sampling should be made not later than 24 h prior to the test.

7. Control

7.1 Fire-Resistance Test:

7.1.1 Time-Temperature Curve:

7.1.1.1 The furnace temperatures shall be controlled to follow the standard time-temperature curve shown in Fig. 1. The points on the curve that determine its character are:

1000°F (538°C)	at 5 min
1300°F (704°C)	at 10 min
1550°F (843°C)	at 30 min
1700°F (927°C)	at 1 h
1850°F (1010°C)	at 2 h
2000°F (1093°C)	at 4 h
2300°F (1260°C)	at 8 h or over

7.1.1.2 For a more detailed definition of the time-temperature curve, see Appendix X1.

NOTE 4—*Recommendations for Recording Fuel Flow to Furnace Burners*—The following provides guidance on the desired characteristics of instrumentation for recording the flow of fuel to the furnace burners. Fuel flow data may be useful for a furnace heat balance analysis, for measuring the effect of furnace or control changes, and for comparing the performance of test specimens of different properties in the fire-resistance test.⁴

Record the integrated (cumulative) flow of gas (or other fuel) to the furnace burners at 10 min, 20 min, 30 min, and every 30 min thereafter or more frequently. Total gas consumed during the total test period is also to be determined. A recording flow meter has advantages over periodic readings on an instantaneous or totalizing flow meter. Select a measuring and recording system to provide flow rate readings accurate to within ±5 %.

⁴ Harmathy, T. Z., "Design of Fire Test Furnaces," *Fire Technology*, Vol. 5, No. 2, May 1969, pp. 146-150; Seigel, L. G., "Effects of Furnace Design on Fire Endurance Test Results," *Fire Test Performance*, ASTM STP 464, ASTM, 1970, pp. 57-67; and Williamson, R. B., and Buchanan, A. H., "A Heat Balance Analysis of the Standard Fire Endurance Test."

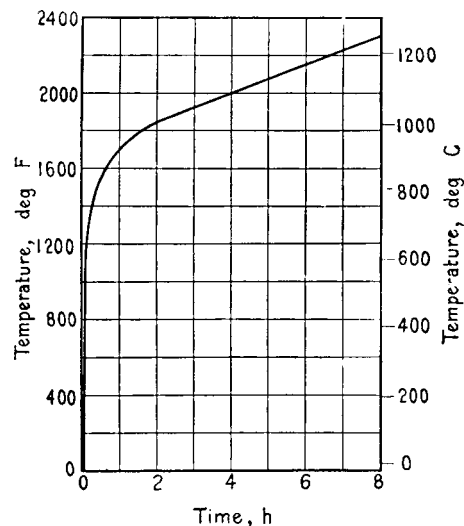

FIG. 1 Time-Temperature Curve

Report the type of fuel, its higher (gross) heating value, and the fuel flow (corrected to standard conditions of 60°F (16°C) and 30.0 in. Hg) as a function of time.

7.2 Furnace Temperatures:

7.2.1 The temperature fixed by the curve shall be the average temperature from not fewer than nine thermocouples for a floor, roof, wall, or partition and not fewer than eight thermocouples for a column. Furnace thermocouples shall be symmetrically disposed and distributed to show the temperature near all parts of the test specimen, the thermocouples being enclosed in protection tubes of such materials and dimensions that the time constant of the protected thermocouple assembly lies within the range from 5.0 to 7.2 min (Note 3). The exposed length of the pyrometer tube and thermocouple in the furnace chamber shall be not less than 12 in. (305 mm). It is not prohibited to use other types of protecting tubes or pyrometers that, under test conditions, give the same indications as the above standard within the limit of accuracy that applies for furnace-temperature measurements.

7.2.1.1 For walls and partitions, the furnace thermocouples shall be placed 6 in. (152 mm) away from the exposed face of the test specimen at the beginning of the test. For all other test specimens, the furnace thermocouples shall be placed 12 in. (305 mm) from the exposed face of the test specimen at the beginning of the test. During the test, furnace thermocouples shall not touch the test specimen in the event of the test specimen's deflection.

NOTE 5—A typical thermocouple assembly meeting these time constant requirements may be fabricated by fusion-welding the twisted ends of No. 18 gage Chromel-Alumel wires, mounting the leads in porcelain insulators and inserting the assembly so the thermocouple bead is 1/2 in. (13 mm) from the sealed end of a standard weight nominal 1/2-in. iron, steel, or Inconel⁵ pipe. The time constant is either measured or calculated from knowledge of its physical and thermal properties. The time constant for this and for several other thermocouple assemblies was measured in 1976.⁶

7.2.2 The furnace temperatures shall be read at intervals not exceeding 5 min during the first 2 h, and thereafter the intervals shall not exceed 10 min.

7.2.3 The accuracy of the furnace control shall be such that the area under the time-temperature curve, obtained by averaging the results from the pyrometer readings, is within 10 % of the corresponding area under the standard time-temperature curve shown in Fig. 1 for fire-resistance tests of 1 h or less duration, within 7.5 % for those over 1 h and not more than 2 h, and within 5 % for tests exceeding 2 h in duration.

7.3 Test Specimen Temperatures:

7.3.1 Temperatures Measurement of the Unexposed Surfaces of Floors, Roofs, Walls, and Partitions:

7.3.1.1 Temperatures of unexposed surfaces shall be measured with thermocouples or thermometers (Note 7) placed under dry, felted pads meeting the requirements listed in Annex A1. The wire leads of the thermocouple or the stem of the thermometer shall have an immersion under the pad and be in contact with the unexposed surface for not less than 3 1/2 in. (89

mm). The hot junction of the thermocouple or the bulb of the thermometer shall be placed approximately under the center of the pad. The outside diameter of protecting or insulating tubes, and of thermometer stems, shall be not more than 5/16 in. (8 mm). The pad shall be held firmly against the surface, and shall fit closely about the thermocouples or thermometer stems. Thermometers shall be of the partial-immersion type, with a length of stem, between the end of the bulb and the immersion mark, of 3 in. (76 mm). The wires for the thermocouple in the length covered by the pad shall be not heavier than No. 18 B&S gage (0.04 in.) (1.02 mm) and shall be electrically insulated with heat-resistant and moisture-resistant coatings.

NOTE 6—For the purpose of testing roof assemblies, the unexposed surface shall be defined as the surface exposed to ambient air.

NOTE 7—Under certain conditions it may be unsafe or impracticable to use thermometers.

7.3.1.2 Temperatures shall be recorded at not fewer than nine points on the surface. Five of these shall be symmetrically disposed, one to be approximately at the center of the test specimen, and four at approximately the center of its quarter sections. The other four shall be located to obtain representative information on the performance of the test specimen. The thermocouples shall not be located closer to the edges of the test specimen than one and one-half times the thickness of the test specimen, or 12 in. (305 mm). Exception: those cases in which there is an element of the construction that is not otherwise represented in the remainder of the test specimen. The thermocouples shall not be located opposite or on top of beams, girders, pilasters, or other structural members if temperatures at such points will be lower than at more representative locations. The thermocouples shall not be located over fasteners such as screws, nails, or staples that will be higher or lower in temperature than at a more representative location if the aggregate area of any part of such fasteners on the unexposed surface is less than 1 % of the area within any 6-in. (152-mm) diameter circle, unless the fasteners extend through the assembly.

7.3.1.3 Temperature readings shall be taken at intervals not exceeding 15 min until a reading exceeding 212°F (100°C) has been obtained at any one point. Thereafter the readings are permitted to be taken more frequently at the discretion of the testing body, but the intervals need not be less than 5 min.

7.3.1.4 Where the conditions of acceptance place a limitation on the rise of temperature of the unexposed surface, the temperature end point of the fire-resistance period shall be determined by the average of the measurements taken at individual points; except that if a temperature rise 30 % in excess of the specified limit occurs at any one of these points, the remainder shall be ignored and the fire-resistance period judged as ended.

7.3.2 Temperature Measurement of Non-loaded Structural Steel Columns (Alternative Test of Steel Columns):

7.3.2.1 Measure the temperature of the steel with not fewer than three thermocouples at each of four levels. The upper and lower levels shall be 2 ft (0.6 m) from the ends of the steel column, and the two intermediate levels shall be equally spaced. For situations in which the protection material thickness is not uniform along the test specimen length, at least one

⁵ Inconel is a registered trademark of INCO Alloys, Inc., 3800 Riverside Dr., P. O. Box 1958, Huntington, WV 25720.

⁶ Supporting data are available from ASTM Headquarters. Request E05-1001.

of the levels at which temperatures are measured shall include the point of minimum cover. Place the thermocouples at each level to measure temperatures of the component elements of the steel section.

7.3.3 *Temperature Measurement of the Components of Floors and Roofs:*

7.3.3.1 For steel floor or roof units, locate four thermocouples on each section (a section to comprise the width of one unit), one on the bottom plane of the unit at an edge joint, one on the bottom plane of the unit remote from the edge, one on a side wall of the unit, and one on the top plane of the unit. The thermocouples shall be applied, where practicable, to the surface of the units remote from fire and spaced across the width of the unit. No more than four or fewer than two sections need be so instrumented in each representative span. Locate the groups of four thermocouples in representative locations spaced across the width of the unit. Typical thermocouple locations for a unit section are shown in Fig. 2.

7.3.3.2 For test specimens employing structural members (beams, open-web steel joists, etc.) spaced at more than 4 ft (1.2 m) on centers, measure the temperature of the steel in these members with four thermocouples at each of three or more sections equally spaced along the length of the members. For situations in which the protection material thickness is not uniform along the test specimen length, at least one of the sections at which temperatures are measured shall include the point of minimum cover.

7.3.3.3 For test specimens employing structural members (beams, open-web steel joists, etc.) spaced at 4 ft (1.2 m) on center or less, measure the temperature of the steel in these members with four thermocouples placed on each member. No more than four members shall be so instrumented. Place the thermocouples at locations, such as at mid-span, over joints in the ceiling, and over light fixtures. It shall not be required that all four thermocouples be located at the same section.

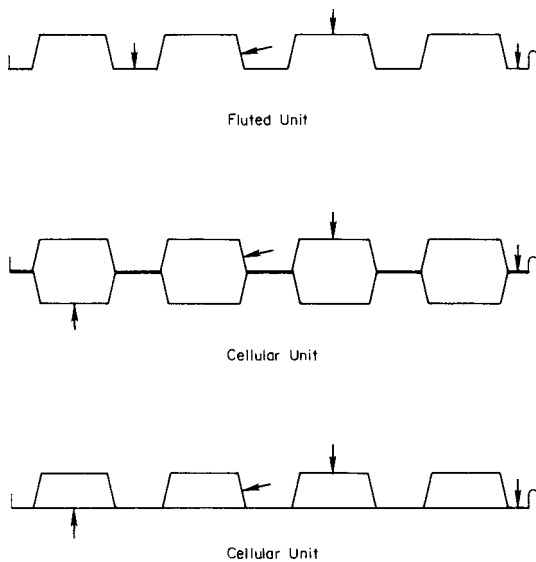

FIG. 2 Typical Location of Thermocouples

7.3.3.4 For steel structural members, locate thermocouples as shown in Fig. 3: two on the bottom of the bottom flange or chord, one on the web at the center, and one on the top flange or chord.

7.3.3.5 For reinforced or pre-stressed concrete structural members, locate thermocouples on each of the tension reinforcing elements, unless there are more than eight such elements, in which case place thermocouples on eight elements selected in such a manner as to obtain representative temperatures of all the elements.

7.3.4 *Temperature Measurement of Loaded Restrained Beams:*

7.3.4.1 Measure the temperature of the steel structural members with four thermocouples at each of three or more sections equally spaced along the length of the members. For situations in which the protection material thickness is not uniform along the test specimen length, at least one of the sections at which temperatures are measured shall include the point of minimum cover.

7.3.4.2 For steel structural members, locate the thermocouples as shown in Fig. 3: two on the bottom of the bottom flange or chord, one on the web at the center, and one on the bottom of the top flange or chord.

7.3.4.3 For reinforced or pre-stressed concrete structural members, locate thermocouples on each of the tension reinforcing elements unless there are more than eight such elements, in which case place thermocouples on eight elements selected in such a manner as to obtain representative temperatures of all the elements.

7.3.5 *Temperature Measurement of Non-loaded Structural Steel Beams and Girders:*

7.3.5.1 Measure the temperature of the steel with not fewer than four thermocouples at each of four sections equally spaced along the length of the member no nearer than 2 ft (0.6 m) from the inside face of the furnace. For situations in which the protection material thickness is not uniform along the test specimen length, at least one of the sections at which temperatures are measured shall include the point of minimum cover. Place the thermocouples at each section to measure temperatures of the component elements of the steel section.

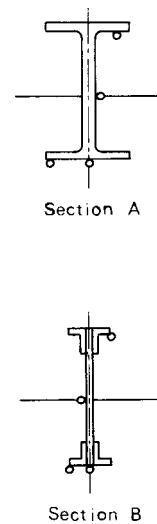

FIG. 3 Typical Location of Thermocouple

7.3.6 *Temperature Measurement of Protective Membranes:*

7.3.6.1 The temperature of protective membranes shall be measured with thermocouples, the measuring junctions of which are in intimate contact with the exposed surface of the elements being protected. The diameter of the wires used to form the thermo-junction shall not be greater than the thickness of sheet metal framing or panel members to which they are attached and in no case greater than No. 18 B&S gage (0.040 in.) (1.02 mm). The lead shall be electrically insulated with heat-resistant and moisture-resistant coatings.

7.3.6.2 For each class of elements being protected, temperature readings shall be taken at not fewer than five representative points. Thermocouples shall be located not less than 12 in. (305 mm) from the edges of the test specimen. An exception is made in those cases in which there is an element or feature of the construction that is not otherwise represented in the test specimen. None of the thermocouples shall be located opposite, on top of, or adjacent to fasteners such as screws, nails, or staples when such locations are excluded for thermocouple placement on the unexposed surface of the test specimen in **7.3.1.2**.

7.3.6.3 Thermocouples shall be located to obtain information on the temperature at the interface between the exposed membrane and the substrate or element being protected.

7.3.6.4 Temperature readings shall be taken at intervals not exceeding 5 min.

7.4 *Loading:*

7.4.1 *Loading of Loadbearing Walls and Partitions:*

7.4.1.1 Throughout the fire-resistance and hose-stream tests, apply a superimposed load to the test specimen to simulate a maximum-load condition. This load shall be the maximum-load condition allowed under nationally recognized structural design criteria unless limited design criteria are specified and a corresponding reduced load is applied (**Note 8**). A double wall assembly shall be loaded during the test to simulate field-use conditions, with either side loaded separately or both sides together (**Note 9**). The method used shall be reported.

NOTE 8—Examples of calculating the superimposed load for bearing lightweight wood-frame walls using the allowable stress design method and load and resistance factor design method are provided in **X7.5**. Also, an example for calculating the superimposed load for bearing lightweight cold-formed steel walls using the load and resistance factor design method is provided in **X7.6**.

NOTE 9—The choice depends on the intended use, and whether the load on the exposed side, after it has failed, will be transferred to the unexposed side. If, in the intended use, the load from the structure above is supported by both walls as a unit and would be or is transferred to the unexposed side in case of collapse of the exposed side, both walls should be loaded in the test by a single unit. If, in the intended use the load from the structure above each wall is supported by each wall separately, the walls should be loaded separately in the test by separate load sources. If the intended use of the construction system being tested involved situations of both loading conditions described above, the walls should be loaded separately in the test by separate load sources. In tests conducted with the walls loaded separately, the condition of acceptance requiring the walls to maintain the applied load shall be based on the time at which the first of either of the walls fails to sustain the load.

7.4.2 *Loading of Columns:*

7.4.2.1 Throughout the fire-resistance test, apply a superimposed load to the test specimen to simulate a maximum-load

condition. This load shall be the maximum-load condition allowed under nationally recognized structural design criteria unless limited design criteria are specified and a corresponding reduced load is applied (**Note 10**). Make provision for transmitting the load to the exposed portion of the column without increasing the effective column length.

NOTE 10—An example for calculating the superimposed load for concrete columns using the load and resistance factor design method is provided in **X7.4**.

7.4.2.2 As an optional procedure, subject the column to 1-³/₄ times its designed working load before undertaking the fire-resistance test. The fact that such a test has been made shall not be construed as having had a deleterious effect on the fire-resistance test performance.

7.4.3 *Loading of Floors and Roofs:*

7.4.3.1 Throughout the fire-resistance test, apply a superimposed load to the test specimen to simulate a maximum-load condition. This load shall be the maximum-load condition allowed under nationally recognized structural design criteria unless limited design criteria are specified and a corresponding reduced load is applied (**Note 11**).

NOTE 11—Examples for calculating the superimposed load for lightweight wood-frame floors using the allowable stress design method and load and resistance factor design method are provided in **X7.5**. Also, an example for calculating the superimposed load for lightweight cold-formed steel floors using the load and resistance factor design method is provided in **X7.6**.

7.4.4 *Loading of Beams:*

7.4.4.1 Throughout the fire-resistance test, apply a superimposed load to the test specimen to simulate a maximum-load condition. This load shall be the maximum load condition allowed under nationally recognized structural design criteria unless limited design criteria are specified and a corresponding reduced load is applied.

7.5 *Cotton Waste Test:*

7.5.1 Where required by the conditions of acceptance in other sections of this standard to determine that the test specimen has not allowed the passage of gases hot enough to ignite cotton waste, the test described in **7.5.7** shall be conducted during the fire-resistance test.

7.5.2 The cotton waste test shall be conducted using a cotton pad as described in **7.5.3** and **7.5.4** in a wire frame provided with a handle as described in **7.5.5**.

7.5.3 The cotton pad shall comply with the physical characteristics described in **7.5.3.1** through **7.5.3.3**.

7.5.3.1 The cotton pad shall be nominally 4 by 4 in. (100 by 100 mm) by 0.75 in. (19 mm) thick.

7.5.3.2 The cotton pad shall consist of new, undyed, soft cotton fibers, without any admixture of artificial fibers.

7.5.3.3 The cotton pad shall weigh 0.12 ± 0.02 oz (3.5 ± 0.5 g).

7.5.4 The cotton pad shall be conditioned prior to the test by drying in an oven at $212 \pm 9^\circ\text{F}$ ($100 \pm 5^\circ\text{C}$) for a period of not less than 30 min. Immediately upon removal from the drying oven, the cotton pad shall be stored in a desiccator for a period of not less than 24 h prior to the fire-resistance test.

7.5.5 The frame used to hold the cotton pad for the purpose of the cotton waste test shall be constructed using No. 16 AWG

(0.05 in.) (1.3 mm) steel wire which has been fastened to a handle that has a length that reaches all points on the unexposed surface of the test specimen. See Fig. 4.

7.5.6 Ignition of the cotton pad shall be defined as glowing, flaming or smoldering of the cotton pad. Charring of the cotton pad shall not be an indication of ignition.

7.5.7 Ignition Test Procedure:

7.5.7.1 After a crack, hole, opened joint, or other similar void or defect is observed in the unexposed surface of the test specimen that permits the passage of hot gasses, conduct the cotton waste test using an unused cotton pad.

7.5.7.2 Position the cotton pad directly over the observed crack, hole, opened joint, or other similar void or defect in the unexposed surface of the test specimen, approximately $1 \pm \frac{1}{8}$ in. (25 ± 3 mm) from the surface, for a period of 30 ± 1 s or until ignition of the cotton pad, whichever occurs first.

7.5.7.3 All test locations previously tested in accordance with 7.5.7.2 shall be retested as close as practical to the end of

the desired fire-resistance period. An unused cotton pad shall be positioned over each previously tested location on the unexposed surface of the test specimen.

7.5.7.4 The time to ignition of the cotton pad shall be recorded.

7.6 Hose Stream:

7.6.1 Where required by the conditions of acceptance, a test shall be conducted to subject the test specimen described in 7.6.2 or 7.6.3 to the impact, erosion, and cooling effects of a hose stream. The hose stream shall be applied in accordance with Practice E2226. The water pressure and duration of application shall be as prescribed in Table 1 of Practice E2226.

7.6.1.1 Exemption—The hose-stream test shall not be required in the case of test specimens having a resistance period, indicated in the fire-resistance test, of less than 1 h.

7.6.2 The hose stream test shall be conducted on a duplicate test specimen.

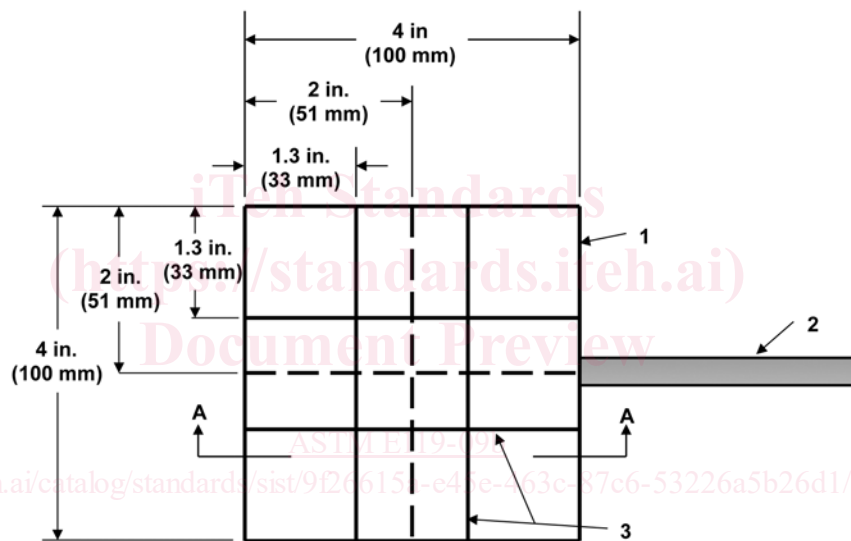

Note: All dimensions shall have a tolerance of $\pm 1/16$ in. (1.6 mm)

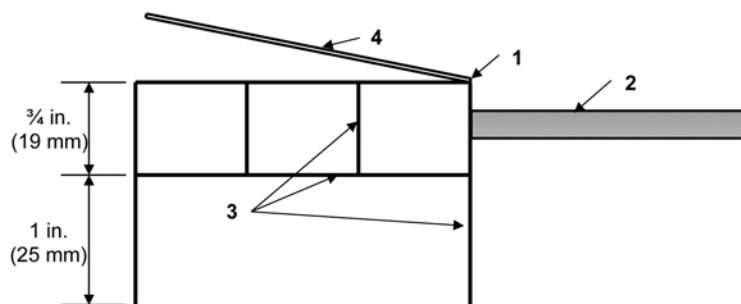

Section A-A

- 1. Hinge
- 2. Handle
- 3. 16 AWG (0.05 in.)(1.3 mm) diameter steel framework
- 4. Hinged lid with latch

FIG. 4 Typical Cotton Waste Pad Holder

7.6.2.1 The duplicate test specimen shall be exposed to the effects of the hose stream immediately after being subjected to a fire-resistance test for a time period of one-half the fire-resistance classification period determined from the fire-resistance test on the initial test specimen.

7.6.2.2 The length of time that the duplicate test specimen is subjected to the fire-resistance test shall not exceed 1 h.

7.6.3 *Optional Program*—As an alternative procedure, conduct the hose stream test on the initially tested test specimen immediately following its fire-resistance test.

8. Procedure

8.1 General:

8.1.1 Continue the fire-resistance test on the test specimen with its applied load, if any, until failure occurs, or until the test specimen has withstood the test conditions for a period equal to that herein specified in the conditions of acceptance for the given type of building element.

8.1.2 Continue the test beyond the time fire-resistance classification is determined, when the purpose in doing so is to obtain additional information.

8.2 Tests of Loadbearing Walls and Partitions:

8.2.1 *Size of Test Specimen*—The area exposed to fire shall be not less than 100 ft² (9 m²), with neither dimension less than 9 ft (2.7 m). The test specimen shall not be restrained on its vertical edges.

8.2.2 *Temperatures*—Determine temperatures in accordance with 7.3.1.

8.2.3 *Loading*—Load the test specimen in accordance with 7.4.1.

8.2.4 *Conditions of Acceptance*—Regard the test as successful if the following conditions are met:

8.2.4.1 The test specimen shall have sustained the applied load during the fire-resistance test without passage of flame or gases hot enough to ignite cotton waste, for a period equal to that for which classification is desired.

8.2.4.2 The test specimen shall have sustained the applied load during the fire and hose stream test as specified in 7.6, without passage of flame, of gases hot enough to ignite cotton waste, or with the passage of water of from the hose stream. The test specimen shall be considered to have failed the hose stream test if an opening develops that permits a projection of water from the stream beyond the unexposed surface during the time of the hose stream test.

8.2.4.3 Transmission of heat through the wall or partition during the fire-resistance test shall not raise the temperature on its unexposed surface more than 250°F (139°C) above its initial temperature.

8.3 Tests of Non-Loadbearing Walls and Partitions:

8.3.1 *Size of Test Specimen*—The area exposed to fire shall be not less than 100 ft² (9 m²), with neither dimension less than 9 ft (2.7 m). Restrain the test specimen on all four edges.

8.3.2 *Temperatures*—Determine temperatures in accordance with 7.3.1.

8.3.3 *Loading*—There is no requirement for loading.

8.3.4 *Conditions of Acceptance*—Regard the test as successful if the following conditions are met:

8.3.4.1 The test specimen has withstood the fire-resistance test without passage of flame or gases hot enough to ignite cotton waste, for a period equal to that for which classification is desired.

8.3.4.2 The test specimen has withstood the fire and hose stream test as specified in 7.6, without passage of flame, of gases hot enough to ignite cotton waste, or of passage of water from the hose stream. The test specimen shall be considered to have failed the hose stream test if an opening develops that permits a projection of water from the stream beyond the unexposed surface during the time of the hose stream test.

8.3.4.3 Transmission of heat through the wall or partition during the fire-resistance test shall not raise the temperature on its unexposed surface more than 250°F (139°C) above its initial temperature.

8.4 Tests of Loaded Columns:

8.4.1 *Size of Test Specimen*—The length of the column exposed to fire shall be not less than 9 ft (2.7 m). Apply the contemplated details of connections and their protection, if any, according to the methods of field practice. The column shall be vertical during the fire exposure.

8.4.2 *Temperatures*—There is no requirement for temperature measurements.

8.4.3 *Loading*—Load the test specimen in accordance with 7.4.2.

8.4.4 *Condition of Acceptance*—Regard the test as successful if the column sustains the applied load during the fire-resistance test for a period equal to that for which classification is desired.

8.5 Alternative Test of Non-loaded Steel Columns:

8.5.1 *Application*—This alternative test procedure is used to evaluate the protection of steel columns without application of design load, provided that the protection material is not required by design to function structurally in resisting loads.

8.5.2 Size and Characteristics of Test Specimen:

8.5.2.1 The length of the protected column shall be at least 8 ft (2.4 m). The column shall be vertical during the fire exposure.

8.5.2.2 Restrain the applied protection material against longitudinal temperature expansion greater than that of the steel column with rigid steel plates or reinforced concrete attached to the ends of the steel column before the protection is applied. The size of the plates or amount of concrete shall provide direct bearing for the entire transverse area of the protection material.

8.5.2.3 Provide the ends of the test specimen, including the means for restraint, with thermal insulation to limit direct heat transfer from the furnace.

8.5.2.4 Throughout the fire-resistance test, expose the test specimen to fire on all sides for its full length.

8.5.3 *Temperatures*—Determine temperatures in accordance with 7.3.2.

8.5.4 *Loading*—There is no requirement for loading.

8.5.5 *Conditions of Acceptance*—Regard the test as successful if the transmission of heat through the protection during the period of fire exposure for which classification is desired does not raise the average (arithmetical) temperature of the steel at

any one of the four levels above 1000°F (538°C), or does not raise the temperature above 1200°F (649°C) at any one of the measured points.

8.6 Tests of Floors and Roofs:

8.6.1 *Application*—This procedure is applicable to floor and roof assemblies with or without attached, furred, or suspended ceilings and requires the application of the fire exposure to the underside of the test specimen.

8.6.1.1 Two fire-resistance classifications shall be determined for test specimens restrained against thermal expansion: a restrained assembly classification based upon the conditions of acceptance specified in 8.6.5 and an unrestrained assembly classification based upon the conditions of acceptance specified in 8.6.6.

NOTE 12—See Appendix X3, which is intended as a guide for assisting the user of this test method in determining the conditions of thermal restraint applicable to floor and roof constructions and individual beams in actual building construction.

8.6.1.2 An unrestrained assembly classification shall be determined for test specimens not restrained against thermal expansion based upon the conditions of acceptance specified in 8.6.6.1 and 8.6.6.2.

8.6.1.3 As an alternative classification procedure for loaded restrained beams specified in 8.7, an individual unrestrained beam classification shall be permitted for beams from restrained or unrestrained floor or roof specimens, based on the conditions of acceptance specified in 8.7.6. The unrestrained beam classification so derived shall be applicable to beams used with a floor or roof construction that has comparable or greater capacity for heat dissipation than that with which it was tested. The fire-resistance classification developed by this test method shall not be applicable to sizes of beams smaller than those tested.

8.6.2 Size and Characteristics of Test Specimen:

8.6.2.1 The area exposed to fire shall be not less than 180 ft² (16 m²) with neither dimension less than 12 ft (3.7 m). Structural members, if a part of the test specimen, shall be positioned within the combustion chamber and have a side clearance of not less than 8 in. (203 mm) from the chamber walls.

8.6.2.2 Test specimens for which a restrained rating is desired shall be so restrained during the test exposure.

8.6.3 *Temperatures*—Determine temperatures in accordance with 7.3.1 and 7.3.3.

8.6.4 *Loading*—Load the test specimen in accordance with 7.4.3.

8.6.5 *Conditions of Acceptance—Restrained Assembly Classification*—In obtaining a restrained assembly classification, the following conditions shall be met:

8.6.5.1 The test specimen shall have sustained the applied load during its classification period without developing unexposed surface conditions which will ignite cotton waste.

8.6.5.2 Transmission of heat through the test specimen during its classification period shall not raise the average temperature on its unexposed surface more than 250°F (139°C) above its initial temperature.

8.6.5.3 For test specimens employing steel structural members (beams, open-web steel joists, etc.) spaced more than 4 ft

(1.2 m) on centers, the test specimen shall achieve a restrained assembly classification on the basis of the temperature of the steel structural members not having exceeded 1300°F (704°C) at any location and not having the average temperature recorded by four thermocouples at any section exceed 1100°F (593°C) during the first hour. For restrained assembly classifications greater than 1 h, these temperature criteria shall apply for a period of one half the classification period of the floor or roof construction or 1 h, whichever is the greater.

8.6.5.4 For test specimens employing steel structural members (beams, open-web steel joists, etc.) spaced 4 ft (1.2 m) or less on centers, the test specimen shall achieve a restrained assembly classification on the basis of the average temperature of the steel structural members, as recorded by all thermocouples, not having exceeded 1100°F (593°C) during the first hour. For restrained assembly classifications greater than 1 h, this temperature shall apply for a period of one half the classification period of the floor or roof construction or 1 h, whichever is the greater.

8.6.5.5 For test specimens employing conventionally designed concrete beams spaced more than 4 ft (1.2 m) on centers, the test specimen shall achieve a restrained assembly classification on the basis of the average temperature of the tension steel at any section of the concrete beam not having exceeded 800°F (427°C) for cold-drawn prestressing steel or 1100°F (593°C) for reinforcing steel during the first hour. For restrained assembly classifications greater than 1 h, these temperature criteria shall apply for a period of one half the classification period of the floor or roof construction or 1 h, whichever is the greater.

8.6.5.6 The fire resistance classification of a restrained assembly shall be reported as that developed by applying the conditions of acceptance specified in 8.6.5.1 and 8.6.5.2, and where applicable, to the conditions in 8.6.5.3 through 8.6.5.5.

8.6.6 *Conditions of Acceptance—Unrestrained Assembly Classification*—In obtaining an unrestrained assembly classification, the following conditions shall be met:

8.6.6.1 The test specimen shall have sustained the applied load during its classification period without developing unexposed surface conditions which will ignite cotton waste.

8.6.6.2 Transmission of heat through the test specimen during its classification period shall not raise the average temperature on its unexposed surface more than 250°F (139°C) above its initial temperature.

8.6.6.3 For test specimens employing steel structural members (beams, open-web steel joists, etc.), spaced more than 4 ft (1.2 m) on centers, the temperature of the steel structural members shall not have exceeded 1300°F (704°C) at any location during the classification period nor shall the average temperature recorded by four thermocouples at any section have exceeded 1100°F (593°C) during the classification period.

8.6.6.4 For test specimens employing steel structural members (beams, open-web steel joists, etc.), spaced 4 ft (1.2 m) or less on center, the average temperature recorded by all joist or beam thermocouples shall not have exceeded 1100°F (593°C) during the classification period.

8.6.6.5 For test specimens employing conventionally designed concrete structural members (excluding cast-in-place

concrete roof or floor slabs having spans equal to or less than those tested), the average temperature of the tension steel at any section shall not have exceeded 800°F (427°C) for cold-drawn prestressing steel or 1100°F (593°C) for reinforcing steel during the classification period.

8.6.6.6 For test specimens employing steel floor or roof units intended for use in spans greater than those tested, the average temperature recorded by all thermocouples located on any one span of the floor or roof units shall not have exceeded 1100°F (593°C) during the classification period.

8.6.6.7 The fire-resistance classification of an unrestrained assembly shall be reported as that developed by applying the conditions of acceptance specified in 8.6.6.1 and 8.6.6.2 and, where applicable, to the conditions in 8.6.6.3 through 8.6.6.6.

8.7 Tests of Loaded Restrained Beams:

8.7.1 Application:

8.7.1.1 An individual restrained beam classification shall be determined from tests by this procedure for loaded restrained beams based upon the conditions of acceptance specified in 8.7.5. The restrained beam classification so derived shall be applicable to beams used with a floor or roof construction that has comparable or greater capacity for heat dissipation than that with which it was tested. The fire-resistance classification developed by this method shall not be applicable to sizes of beams smaller than those tested.

8.7.1.2 As an alternative classification procedure for loaded restrained beams specified in 8.7.1.1, an individual unrestrained beam classification shall be determined from tests by this procedure for loaded restrained beams, based upon the conditions of acceptance specified in 8.7.6. The unrestrained beam classification so derived shall be applicable to beams used with a floor or roof construction that has comparable or greater capacity for heat dissipation than that with which it was tested. The fire-resistance classification developed by this test method shall not be applicable to sizes of beams smaller than those tested.

8.7.2 Size and Characteristics of Test Specimen:

8.7.2.1 The test specimen shall be tested in a horizontal position and its length exposed to the fire shall be not less than 12 ft (3.7 m).

8.7.2.2 For test specimens tested with a representative section of a floor or roof assembly, such sections shall not be wider than 7 ft (2.1 m) and shall be symmetrically located with reference to the beam.

8.7.2.3 Restrain the beam and those portions of the floor or roof assembly that are integral to the structural design of the beam, against the potential effects from thermally induced longitudinal expansion. The restraint shall replicate the restraint expected to occur in building construction. Do not support or restrain portions of the perimeter of the floor or roof assembly that are not integral to the structural beam design.

NOTE 13—Composite steel construction and concrete construction that incorporate beams as an integral part of the structural design are examples where portions of the floor or roof assembly that are attached to the beam should be restrained against thermal expansion. Restraining the portion of the concrete slab that is integral to the structural design of the beam serves the intent of providing restraint against thermal rotation of the test specimen. It is not permitted to restrain portions of the perimeter of the

test specimen other than that part that is integral to the structural design of the beam.

8.7.3 *Temperatures*—Determine temperatures in accordance with 7.3.4.

8.7.4 *Loading*—Load the test specimen in accordance with 7.4.4.

8.7.5 *Conditions of Acceptance—Restrained Beam Classification*—In obtaining a restrained beam classification, the following conditions shall be met:

8.7.5.1 The test specimen shall have sustained the applied load during its classification period.

8.7.5.2 For steel beams: during the first hour or during the first half of its classification period, whichever is the greater, the temperature of the steel shall not have exceeded 1300°F (704°C) at any location nor shall the average temperature recorded by four thermocouples at any section have exceeded 1100°F (593°C).

8.7.6 *Alternative Conditions of Acceptance—Unrestrained Beam Classification*—In obtaining an unrestrained beam classification, the following conditions shall be met:

8.7.6.1 The test specimen shall have sustained the applied load during its classification period.

8.7.6.2 For steel beams, the temperature of the steel shall not have exceeded 1300°F (704°C) at any location nor shall the average temperature recorded by four thermocouples at any section have exceeded 1100°F (593°C) during its classification period.

8.7.6.3 For conventionally designed concrete beams, the average temperature of the tension steel at any section shall not have exceeded 800°F (427°C) for cold-drawn prestressing steel or have exceeded 1100°F (593°C) for reinforcing steel during its classification period.

8.8 Alternative Tests of Protection for Unloaded Solid Structural Steel Beams and Girders:

8.8.1 *Application*—This alternative test procedure is used to evaluate the protection of solid steel beams and girders without the application of a design load, provided that the protection material is not required by design to function structurally in resisting applied loads. The classification so derived shall be applicable to solid steel structural members when used with a floor or roof construction that has a comparable or greater capacity for heat dissipation than that with which it was tested. The classification shall not be applicable to sizes of beams smaller than those tested.

8.8.2 Size and Characteristics of Test Specimen:

8.8.2.1 The test specimen shall be tested in a horizontal position and the length of the beam or girder exposed to the fire shall be not less than 12 ft (3.7 m). A section of a representative floor or roof construction not less than 5 ft (1.5 m) wide, shall be symmetrically located with reference to the beam or girder and extending the full length of the test specimen and shall be included in the test specimen.

8.8.2.2 Restrain the applied protection material against longitudinal temperature expansion greater than that of the steel beam or girder with rigid steel plates or reinforced concrete attached to the ends of the steel beams before the protection material is applied. Provide the ends of the test specimen,

including the means for restraint, with thermal insulation to limit direct heat transfer from the furnace.

8.8.3 *Temperatures*—Determine temperatures in accordance with 7.3.5.

8.8.4 *Loading*—There is no requirement for loading.

8.8.5 *Conditions of Acceptance*:

8.8.5.1 Regard the test as successful if the transmission of heat through the protection material during the period of fire exposure for which classification is desired does not raise the average (arithmetical) temperature of the steel at any one of the four sections above 1000°F (538°C), or does not raise the temperature above 1200°F (649°C) at any one of the measured points.

8.9 *Tests of Protective Membranes in Walls, Partition, Floor, or Roof Assemblies*:

8.9.1 *Application*—To determine the thermal protection afforded by membrane elements in wall, partition, floor, or roof assemblies, the nonstructural performance of protective membranes shall be obtained by the procedure given in 8.9. The performance of protective membranes is supplementary information only and is not a substitute for the fire-resistance classification determined elsewhere in this fire-test-response standard.

8.9.2 *Size of Test Specimen*—The size of the test specimen shall conform with 8.2.1 for loadbearing walls and partitions, with 8.3.1 for non-loadbearing walls and partitions, and with 8.6.2.1 for floors and roofs.

8.9.3 *Temperatures*—Determine temperatures in accordance with 7.3.6.

8.9.4 *Loading*—There is no requirement for loading.

8.9.5 *Conditions of Acceptance*—Unless otherwise specified, the performance of protective membranes shall be determined as the time at which the following conditions occur:

8.9.5.1 The average temperature rise of any set of thermocouples for each class of element being protected is more than 250°F (139°C) above the initial temperature, or

8.9.5.2 The temperature rise of any one thermocouple of the set for each class of element being protected is more than 325°F (181°C) above the initial temperature.

8.9.6 *Report of Results*:

8.9.6.1 The protective membrane performance, for each class of element being protected, shall be reported to the nearest integral minute.

8.9.6.2 The test report shall identify each class of elements being protected and shall show the location of each thermocouple.

8.9.6.3 The test report shall show the time-temperature data recorded for each thermocouple and the average temperature for the set of thermocouples on each element being protected.

9. Report of Results

9.1 Results shall be reported in accordance with the performance in the tests prescribed in these test methods. They shall be expressed in time periods of resistance, to the nearest integral minute. Reports shall include observations of details of the behavior of the material or construction during the test and after the furnace fire is extinguished, including information on

deformation, spalling, cracking, burning of the test specimen or its component parts, continuance of flaming, and production of smoke.

9.2 Reports of tests in which restraint is provided for the test specimen shall describe the method used to provide the restraint.

9.2.1 Describe the physical details of the restraint system and provide information to define the longitudinal and rotational resistance of the test specimen by the restraint system.

9.2.2 Describe the restraint conditions with regard to the free movement of the test specimen prior to encountering resistance to expansion, contraction or rotation.

9.3 Reports of tests in which other than maximum load conditions are imposed shall fully define the conditions of loading used in the test and shall be designated in the title of the report of the test as a restricted load condition.

9.4 When the indicated resistance period is ½ h or over, determined by the average or maximum temperature rise on the unexposed surface or within the test specimen, or by failure under load, a correction shall be applied for variation of the furnace exposure from that prescribed, where it will affect the classification, by multiplying the indicated period by two thirds of the difference in area between the curve of average furnace temperature and the standard curve for the first three fourths of the period and dividing the product by the area between the standard curve and a base line of 68°F (20°C) for the same part of the indicated period, the latter area increased by 54°F·h or 30°C·h (3240°F·min or 1800°C·min) to compensate for the thermal lag of the furnace thermocouples during the first part of the test. For fire exposure in the test higher than standard, the indicated resistance period shall be increased by the amount of the correction and be similarly decreased for fire exposure below standard.

NOTE 14—The correction can be expressed by the following equation:

$$C = 2I(A - A_s)/3(A_s + L) \quad \text{E119-09b}$$

where:

C = correction in the same units as I ,

I = indicated fire-resistance period,

A = area under the curve of indicated average furnace temperature for the first three fourths of the indicated period,

A_s = area under the standard furnace curve for the same part of the indicated period, and

L = lag correction in the same units as A and A_s (54°F·h or 30°C·h (3240°F·min or 1800°C·min)).

9.5 Unsymmetrical wall constructions are tested with either side exposed to the fire, and the report shall indicate the side so exposed. When test specimens have been tested with each side separately exposed to the fire, the report then shall indicate the fire-resistance classification determined as a result of each side having been exposed to the fire.

10. Precision and Bias ⁷

10.1 No comprehensive test program has been conducted to develop data on which to derive statistical measures of repeatability (within-laboratory variability) and reproducibility

⁷ Supporting data are available from ASTM Headquarters. Request E05-1003.